

# Switching Devices – Soft Starters and Solid-State Switching Devices

# 6



## Price groups

PG 41B, 41C, 41E, 41F, 41H, 41J, 42G, 42H, 42J, 4N1

6/2

## Introduction

### SIRIUS 3RW soft starters

6/5

General data  
3RW30, 3RW40  
for standard applications

6/8

3RW30

6/19

3RW40

3RW44  
for High-Feature applications

6/37

3RW44

### Solid-state switching devices for resistive loads

6/68

General data  
Solid-state relays

6/71

General data

6/72

SIRIUS 3RF21 solid-state relays,  
single-phase, 22.5 mm

6/77

SIRIUS 3RF20 solid-state relays,  
single-phase, 45 mm

6/81

SIRIUS 3RF22 solid-state relays,  
three-phase, 45 mm

### Solid-state contactors

6/84

General data

6/85

SIRIUS 3RF23 solid-state contactors,  
single-phase

6/94

SIRIUS 3RF24 solid-state contactors,  
three-phase

### Function modules

6/98

General data

6/105

SIRIUS converters for 3RF2

6/106

SIRIUS load monitoring for 3RF2

6/107

SIRIUS heating current monitoring for  
3RF2

6/108

SIRIUS power controllers for 3RF2

6/109

SIRIUS power regulators for 3RF2

### Solid-state switching devices for switching motors

### Solid-state contactors

6/110

General data

6/113

SIRIUS 3RF34 solid-state contactors,  
three-phase

6/117

SIRIUS 3RF34 solid-state reversing  
contactors, three-phase

### Note:

Conversion tool  
e.g. from 3RF24 to 3RF34 see  
[www.siemens.com/sirius/conversion-tool](http://www.siemens.com/sirius/conversion-tool)

# Switching Devices – Soft Starters and Solid-State Switching Devices

## Soft Starters

### Introduction

#### Overview



3RW30

3RW40

3RW44

#### 3RW soft starters

##### 3RW soft starters for standard applications

###### 3RW30 soft starters

- SIRIUS 3RW30 soft starters for soft starting of three-phase asynchronous motors
- Current range of up to 106 A
- Performance range of up to 55 kW (at 400 V), up to 75 hp (at 460 V)

Article No.

Page

**3RW30**

6/8

###### 3RW40 soft starters

- SIRIUS 3RW40 soft starters with the integral functions
  - solid-state motor overload and intrinsic device protection and
  - adjustable current limiting
 for the soft starting and stopping of three-phase asynchronous motors
- Current range of up to 432 A
- Performance range of up to 250 kW (at 400 V), up to 300 hp (at 460 V)

**3RW40**

6/19

##### 3RW soft starters for High-Feature applications

###### 3RW44 soft starters

- In addition to soft starting and soft ramp-down, the solid-state SIRIUS 3RW44 soft starters provide numerous functions for higher-level requirements
- Current range of up to 1 214 A
- Performance range
  - In inline circuit: up to 710 kW (at 400 V), up to 950 hp (at 460 V)
  - In inside-delta circuit: up to 1 200 kW (at 400 V), up to 1 700 hp (at 460 V)

**3RW44**

6/37

#### SIRIUS 3RW soft starters

SIRIUS 3RW soft starters permit soft starting and soft ramp-down of three-phase asynchronous motors. Depending on the scope of functions required it is possible to choose between:

- Soft starters for standard applications
- Soft starters for High-Feature applications

#### SIRIUS 3RW – Service-proven in many applications

Functions of the SIRIUS soft starters include:

- Soft starting and ramp-down
- Stepless starting
- Torque control and limitation

#### Cost-efficient operation

The advantages of SIRIUS soft starters at a glance:

- Reduction of current peaks
- Avoidance of mains voltage fluctuations during starting
- Reduced load on the power supply network
- Reduction of the mechanical load in the operating mechanism
- Considerable space savings and reduced wiring compared with conventional starters
- Maintenance-free switching
- Very easy handling
- Fits perfectly in the SIRIUS modular system (3RW30 and 3RW40)

# Switching Devices – Soft Starters and Solid-State Switching Devices

## Solid-State Switching Devices

## Introduction



		Article No.	Page
<b>SIRIUS solid-state switching devices for switching resistive loads</b>			
<b>Solid-state relays</b>			
<b>Solid-state relays</b>	<ul style="list-style-type: none"> <li>• Widths of 22.5 mm and 45 mm</li> <li>• Compact and space-saving design</li> <li>• "Zero-point switching" version</li> <li>• Mounting onto existing heat sinks</li> </ul>	<b>3RF21</b> <b>3RF20</b> <b>3RF22</b>	6/72 6/77 6/81
<b>Solid-state contactors</b>			
<b>Solid-state contactors</b>	<ul style="list-style-type: none"> <li>• Complete units comprising a solid-state relay and an optimized heat sink, "ready to use"</li> <li>• Compact and space-saving design</li> <li>• Versions for resistive loads "zero-point switching" and inductive loads "instantaneous switching"</li> <li>• Special versions "Low Noise" and "Short-Circuit Proof"</li> </ul>	<b>3RF23</b> <b>3RF24</b>	6/85 6/94
<b>Function modules</b>			
<b>Converters</b>	<p>For extending the functionality of the 3RF21 solid-state relays and the 3RF23 solid-state contactors for many different applications:</p> <ul style="list-style-type: none"> <li>• For converting an analog input signal into an on/off ratio; can also be used on 3RF22 and 3RF24 three-phase switching devices</li> </ul>	<b>3RF2900-0EA18</b>	6/105
<b>Load monitoring</b>	<ul style="list-style-type: none"> <li>• For load monitoring of one or more loads (partial loads)</li> </ul>	<b>3RF29...0FA08,</b> <b>3RF29.0-0GA..</b>	6/106
<b>Heating current monitoring</b>	<ul style="list-style-type: none"> <li>• For load monitoring of one or more loads (partial loads); remote teach</li> </ul>	<b>3RF29...0JA..</b>	6/107
<b>Power controllers</b>	<ul style="list-style-type: none"> <li>• For supplying the current by means of a solid-state switching device depending on a setpoint value. There is a choice of full-wave control and generalized phase control.</li> </ul>	<b>3RF29...0KA.</b>	6/108
<b>Power regulators</b>	<ul style="list-style-type: none"> <li>• For supplying the current by means of a solid-state switching device depending on a setpoint value. Closed-loop control: full-wave control or generalized phase control</li> </ul>	<b>3RF29.0-0HA..</b>	6/109
<b>SIRIUS solid-state switching devices for switching motors</b>			
<b>Solid-state contactors</b>			
<b>Solid-state contactors, solid-state reversing contactors</b>	<ul style="list-style-type: none"> <li>• Complete units in the insulated enclosure with integrated heat sink, "ready to use"</li> <li>• Compact and space-saving design</li> <li>• Version for motors, "instantaneous switching"</li> </ul>	<b>3RF34</b> <b>3RF34</b>	6/113 6/117

# Switching Devices – Soft Starters and Solid-State Switching Devices

## Solid-State Switching Devices

### Introduction

#### SIRIUS 3RF solid-state switching devices



Three-phase solid-state contactor and single-phase solid-state relay

The SIRIUS 3RF2 solid-state switching devices reliably switch a wide range of different loads with alternating voltages in 50 and 60 Hz systems.

SIRIUS 3RF2 solid-state switching devices for resistive loads:

- Solid-state relays
- Solid-state contactors
- Function modules

SIRIUS 3RF3 solid-state switching devices for switching motors:

- Solid-state contactors
- Solid-state reversing contactors

SIRIUS 3RF2 – for almost unending activity

Conventional electromechanical controlgear is often overtaxed by the rise in the number of switching operations. A high switching frequency results in frequent failure and short replacement cycles. However, this does not have to be the case, because with the latest generation of our SIRIUS 3RF2 solid-state switching devices we provide you with solid-state relays and contactors with a particularly long endurance – for almost unending activity even under the toughest conditions and under high mechanical load, but also in noise-sensitive areas.

Proved time and again in service

SIRIUS 3RF2 solid-state switching devices have firmly established in industrial applications. They are used above all in applications where loads are switched frequently – mainly with resistive load controllers, with the control of electrical heat or the control of valves and motors in conveyor systems. In addition to its use in areas with high switching frequencies, their silent switching means that SIRIUS is also ideally suited for use in noise-sensitive areas, such as offices or hospitals.

The most reliable solution for any application

Compared to mechanical controlgear, our SIRIUS 3RF2 solid-state switching devices stand out due to their considerably longer service life. Thanks to the high product quality, their switching is extremely precise, reliable and, above all, unsusceptible to faults. With its variable connection methods and a wide spread of control voltages, the SIRIUS 3RF2 family is universally applicable. Depending on the individual requirements of the application, our modular controlgear can also be quite easily expanded by the addition of standardized function modules.

Ideal for operation with heating control systems

The 3RF2 solid-state switching devices can be used for example in the SIPLUS HCS300I heating control system. They are optimally connected to the digital output module of the HCS300I by means of preassembled cables. This saves considerable wiring outlay in the control circuit and shortens mounting time.

The HCS300I is a modular heating control system for the optimization of plastic processing machines. It enables individual solutions for many different heating control applications. With each basic unit it is possible to use up to four 6-channel digital outputs to control solid-state switching devices and four 4-channel temperature measuring modules. Current or current-and-voltage measuring modules can be used to monitor the loads. Communication with the higher-level control system is performed via PROFIBUS DP.

See also chapter 15, "SIPLUS HCS Heating Control Systems" → "SIPLUS HCS300I heating controller".



SIPLUS heating control system

Also for switching motors

In order to achieve higher productivity, the switching frequency is continuously increased. It is no problem for our SIRIUS solid-state contactors to switch motors. With three-phase motors up to 7.5 kW, they can reliably withstand even the highest switching frequencies. Even a continuous change in the direction of rotation is possible with the solid-state reversing contactors. Both versions can be perfectly combined with components from the SIRIUS modular system. Connecting with SIRIUS motor starter protectors or SIRIUS overload relay can be implemented without any further steps.



Always on the sunny side with SIRIUS

Because SIRIUS 3RF2 offers even more:

- The space-saving and compact side-by-side mounting ensure reliable operation up to an ambient temperature of +60 °C.
- Thanks to fast configuration and the ease of mounting and start-up, you save not only time but also expenses.

**Connection methods**

The solid-state switching devices are available with screw terminals (box terminals), spring-type terminals or ring terminal lugs.

-  Screw terminals
-  Spring-type terminals
-  Ring terminal lug connections

The terminals are indicated in the corresponding tables by the symbols shown on orange backgrounds.

## Overview



		<b>SIRIUS 3RW30</b> Standard applications	<b>SIRIUS 3RW40</b> Standard applications	<b>SIRIUS 3RW44</b> High-Feature applications
<b>Rated current at 40 °C</b>	<b>A</b>	<b>3 ... 106</b>	<b>12.5 ... 432</b>	<b>29 ... 1 214</b>
<b>Rated operational voltage</b>	V	200 ... 480	200 ... 600	200 ... 690 <sup>8)</sup>
<b>Motor rating at 400 V</b>				
• Inline circuit	kW	1.5 ... 55	5.5 ... 250	15 ... 710
	hp	1.5 ... 75	7.5 ... 300	15 ... 950
• Inside-delta circuit	kW	--	--	22 ... 1 200
	hp	--	--	30 ... 1 700
<b>Ambient temperature</b>	°C	-25 ... +60	-25 ... +60	0 ... +60
<b>Soft starting/ramp-down</b>		✓ <sup>1)</sup>	✓	✓
<b>Voltage ramp</b>		✓	✓	✓
<b>Starting/stopping voltage</b>	%	40 ... 100	40 ... 100	20 ... 100
<b>Starting and ramp-down time</b>	s	0 ... 20 <sup>1)</sup>	0 ... 20	0 ... 360
<b>Torque control</b>		--	--	✓
<b>Starting/stopping torque</b>	%	--	--	20 ... 100
<b>Torque limit</b>	%	--	--	20 ... 200
<b>Integral bypass contact system</b>		✓	✓	✓
<b>Intrinsic device protection</b>		--	✓	✓
<b>Motor overload protection</b>		--	✓ <sup>7)</sup>	✓
<b>Thermistor motor protection</b>		--	✓ <sup>2)</sup>	✓
<b>Integrated remote RESET</b>		--	✓ <sup>3)</sup>	✓
<b>Adjustable current limiting</b>		--	✓	✓
<b>Inside-delta circuit</b>		--	--	✓
<b>Breakaway pulse</b>		--	--	✓
<b>Creep speed in both directions of rotation</b>		--	--	✓
<b>Pump ramp-down (torque control)</b>		--	--	✓ <sup>4)</sup>
<b>DC braking</b>		--	--	✓ <sup>4) 5)</sup>
<b>Combined braking</b>		--	--	✓ <sup>4) 5)</sup>
<b>Motor heating</b>		--	--	✓
<b>Communications</b>		--	--	PROFIBUS/PROFINET (optional)
<b>External display and operator module</b>		--	--	(optional)
<b>Operating measured value display</b>		--	--	✓
<b>Error logbook</b>		--	--	✓
<b>Event list</b>		--	--	✓
<b>Slave pointer function</b>		--	--	✓
<b>Trace function</b>		--	--	✓ <sup>6)</sup>
<b>Programmable control inputs and outputs</b>		--	--	✓
<b>Number of parameter sets</b>		1	1	3
<b>Parameterization software (Soft Starter ES)</b>		--	--	✓
<b>Power semiconductors (thyristors)</b>		2 controlled phases	2 controlled phases	3 controlled phases
<b>Screw terminals</b>		✓	✓	✓
<b>Spring-type terminals</b>		✓	✓	✓
<b>UL/CSA</b>		✓	✓	✓
<b>CE marking</b>		✓	✓	✓
<b>Soft starting under heavy starting conditions</b>		--	--	✓ <sup>4)</sup>
<b>Configuring support</b>		Electronic selection slider ruler, Technical Assistance +49 (911) 895-5900		

✓ Function available, -- Function not available

1) Only soft starting available for 3RW30.

2) Optional up to size S3 (device version).

3) For 3RW402. to 3RW404.; for 3RW405. and 3RW407. optional.

4) Calculate soft starter and motor with size allowance where required.

5) Not possible in inside-delta circuit.

6) Trace function with Soft Starter ES software.

7) When using the motor overload protection according to ATEX, an upstream contactor is required.

8) In inside-delta circuit up to 600 V.

More information can be found on the Internet under:  
[www.siemens.com/softstarter](http://www.siemens.com/softstarter)

# SIRIUS 3RW Soft Starters

## General data

### Selection aid for soft starters



Application	SIRIUS 3RW30 Standard applications	SIRIUS 3RW40 Standard applications	SIRIUS 3RW44 High-Feature applications
<b>Normal starting (CLASS 10)</b>			
Pumps	●	●	●
Pumps with special pump ramp-down (to prevent water hammer)			●
Heat pumps	●	●	●
Hydraulic pumps	○	●	●
Presses	○	●	●
Conveyor belts	○	●	●
Roller conveyors	○	●	●
Screw conveyors	○	●	●
Escalators		●	●
Piston compressors		●	●
Screw compressors		●	●
Small fans <sup>1)</sup>		●	●
Centrifugal blowers		●	●
Bow thrusters		●	●
<b>Heavy starting (CLASS 20)</b>			
Stirrers		○	●
Extruders		○	●
Lathes		○	●
Milling machines		○	●
<b>Very heavy starting (CLASS 30)</b>			
Large fans <sup>2)</sup>			●
Circular saws/bandsaws			●
Centrifuges			●
Mills			●
Breakers			●

● Recommended soft starter

○ Possible soft starter

<sup>1)</sup> The mass inertia of the fan is <10 times the mass inertia of the motor.

<sup>2)</sup> The mass inertia of the fan is ≥10 times the mass inertia of the motor.

### Boundary conditions

Type	Maximum starting time	Current loading	Starts per hour
	s	%	1/h
<b>Normal starting (CLASS 10)</b>			
• 3RW30	3	300	20
• 3RW40/44	10	300	5
<b>Heavy starting (CLASS 20)</b>			
• 3RW402., 3RW403., 3RW404.	20	300	5
• 3RW405., 3RW407., 3RW44	40	350	1
<b>Very heavy starting (CLASS 30)</b>			
• 3RW44	60	350	1

The motor ratings listed in the Selection and Ordering Data are rough guide values. The soft starter should always be designed on the basis of the required rated operational current of the motor. 3RW soft starters are designed for easy starting conditions. In case of additional requirements, it may be necessary to choose a larger device. In some cases, however, the safety margins taken into account in the selection also permit the listed units to be used in boundary conditions which are slightly more demanding. Detailed technical information for a configuration which is tailored exactly to the application see "Manuals":  
<http://support.automation.siemens.com/WW/view/en/38752095>  
<http://support.automation.siemens.com/WW/view/en/21772518>

For the configuration of soft starters for motors with high starting current conditions (typically  $I/I_e \geq 8$ ), we recommend consulting our Siemens Technical Assistance  
 Tel.: +49 911 895-5900  
 E-mail: [technical-assistance@siemens.com](mailto:technical-assistance@siemens.com)

Motor rating data in kW and hp are based on IEC 60947-4-1.

## Article No. scheme

Digit of the Article No.	1st - 3rd	4th	5th	6th	7th	8th	9th	10th	11th	12th	13th	14th	15th	16th
	□ □ □	□	□	□	□	-	□	□	□	□	-	□	□	□
<b>Soft starters</b>	<b>3 R W</b>													
<b>SIRIUS soft starter generation</b>														
<b>Size</b>														
<b>Rated operational current <math>I_e</math></b>														
<b>Connection type (screw terminals/spring-type terminals)</b>														
<b>Soft starter functionality (bypass, thermistor, etc.)</b>														
<b>Rated control supply voltage <math>U_s</math></b>														
<b>Rated operational voltage <math>U_e</math></b>														
<b>Special versions</b>														
<b>Example</b>	<b>3 R W</b>	<b>4</b>	<b>0</b>	<b>2</b>	<b>4</b>	<b>-</b>	<b>1</b>	<b>B</b>	<b>B</b>	<b>1</b>	<b>4</b>			

## Note:

The Article No. scheme is presented here merely for information purposes and for better understanding of the logic behind the article numbers.

For your orders, please use the article numbers quoted in the catalog in the Selection and ordering data.

## Benefits

## Advantages through energy efficiency

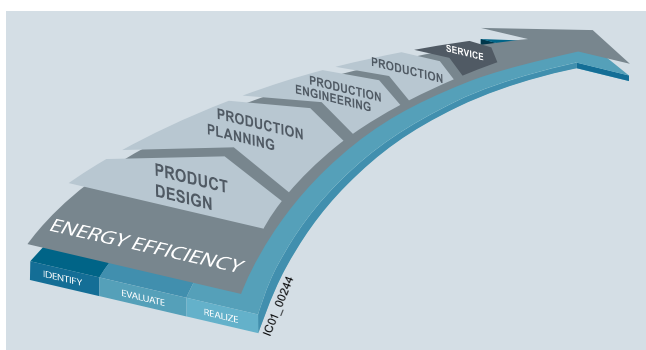

Overview of the energy management process

We offer you a unique portfolio for industrial energy management, using an energy management system that helps to optimally define your energy needs. We split up our industrial energy management into three phases – identify, evaluate, and realize – and we support you with the appropriate hardware and software solutions in every process phase.

The innovative products of the SIRIUS industrial controls portfolio can also make a substantial contribution to a plant's energy efficiency (see [www.siemens.com/sirius/energysaving](http://www.siemens.com/sirius/energysaving)).

The soft starters contribute to energy efficiency throughout the plant as follows:

- Energy management  
Provision of energy data such as current, voltage and power (3RW44) by bus to higher-level systems
- Current management  
Avoidance of current peaks, thus reducing the load on the grid and the mechanical system
- Reduced heating of the control cabinet  
Technology-reduced inherent power loss as speed-controlled drive systems, resulting in lower cooling costs and a more compact design All sizes are equipped with bypass contactor, resulting in lower power losses after start-up

## Product advantages

The advantages of the SIRIUS soft starters at a glance:

- Soft starting and ramp-down (only soft starting available for 3RW30)
- Stepless starting
- Reduction of current peaks
- Avoidance of mains voltage fluctuations during starting
- Reduced load on the power supply network
- Reduction of the mechanical load in the operating mechanism
- Considerable space savings and reduced wiring compared with conventional starters
- Maintenance-free switching
- Very easy handling
- Fits perfectly in the SIRIUS modular system

## Technical specifications

## Permissible installation altitude

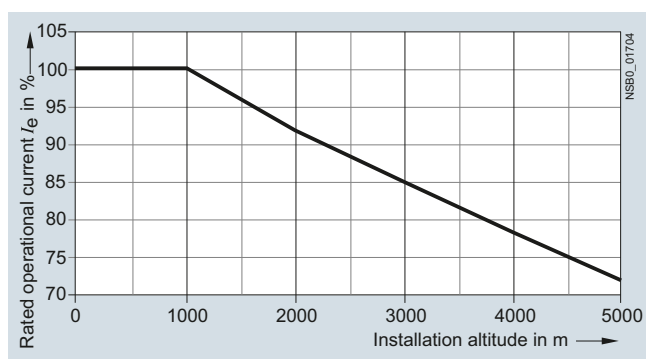

At an installation altitude above 2000 m, max. permissible operational voltage is reduced to 460 V.

# SIRIUS 3RW Soft Starters

## 3RW30, 3RW40 for Standard Applications

### 3RW30

#### Overview

The SIRIUS 3RW30 soft starters reduce the motor voltage through variable phase control and increase it in ramp-like mode from a selectable starting voltage up to mains voltage. During starting, these devices limit the torque as well as the current and prevent the shocks which arise during direct starts or wye-delta starts. In this way, mechanical loads and mains voltage dips can be reliably reduced.

Soft starting reduces the stress on the connected equipment and results in lower wear and therefore longer periods of trouble-free production. The selectable start value means that the soft starters can be adjusted individually to the requirements of the application in question and unlike wye-delta starters are not restricted to two-stage starting with fixed voltage ratios.

The SIRIUS 3RW30 soft starters are characterized above all by their small space requirements. Integrated bypass contacts mean that no power loss has to be taken into the bargain at the power semiconductors (thyristors) after the motor has started up. This cuts down on heat losses, enabling a more compact design and making external bypass circuits superfluous.

Various versions of the SIRIUS 3RW30 soft starters are available:

- Standard version for fixed-speed three-phase motors, sizes S00, S0, S2 and S3, with integrated bypass contact system
- Version for fixed-speed three-phase motors in a 22.5 mm enclosure without bypass

Soft starters rated up to 55 kW (at 400 V) for standard applications in three-phase networks are available. Extremely small sizes, low power losses and simple commissioning are just three of the many advantages of this soft starter.

#### Functionality

The space required by the compact SIRIUS 3RW30 soft starter is often only about one third of that required by a contactor assembly for wye-delta starting of comparable rating. This not only saves space in the control cabinet and on the standard mounting rail but also does away completely with the wiring work needed for wye-delta starters. This is notable in particular for higher motor ratings which are only rarely available as fully wired solutions.

At the same time the number of cables from the starter to the motor is reduced from six to three. Compact dimensions, short start-up times, easy wiring and fast commissioning make themselves felt as clear-cut cost advantages.

The bypass contacts of these soft starters are protected during operation by an integrated solid-state arc quenching system. This prevents damage to the bypass contacts in the event of a fault, e.g. brief disconnection of the control voltage, mechanical shocks or life-related component defects on the coil operating mechanism or main contact spring.

The new series of devices comes with the "polarity balancing" control method, which is designed to prevent direct current components in two-phase controlled soft starters. On two-phase controlled soft starters the current resulting from superimposition of the two controlled phases flows in the uncontrolled phase. This results for physical reasons in an asymmetric distribution of the three phase currents during the motor ramp-up. This phenomenon cannot be influenced, but in most applications it is non-critical.

Controlling the power semiconductors results not only in this asymmetry, however, but also in the previously mentioned direct current components which can cause severe noise generation on the motor at starting voltages of less than 50 %. The control method used for these soft starters eliminates these direct current components during the ramp-up phase and prevents the braking torque which they can cause.

It creates a motor ramp-up that is uniform in speed, torque and current rise, thus permitting a particularly gentle, two-phase starting of the motors. At the same time the acoustic quality of the starting operation comes close to the quality of a three-phase controlled soft starter. This is made possible by the on-going dynamic harmonizing and balancing of current half-waves of different polarity during the motor ramp-up. Hence the name "polarity balancing".

- Soft starting with voltage ramp; the starting voltage setting range  $U_s$  ranges from 40 to 100 %, and the ramp time  $t_R$  can be set from 0 to 20 s.
- Integrated bypass contact system to minimize power loss
- Setting with two potentiometers
- Simple mounting and commissioning
- Mains voltages 50/60 Hz, 200 to 480 V
- Two control voltage versions 24 V AC/DC and 110 to 230 V AC/DC
- Wide temperature range from -25 to +60 °C
- The built-in auxiliary contact ensures user-friendly control and possible further processing within the system (for status graphs see page 6/18).

#### Application

The 3RW30 soft starters are suitable for soft starting of three-phase asynchronous motors.

Due to two-phase control, the current is kept at minimum values in all three phases throughout the entire starting time. Due to continuous voltage influencing, the current and torque peaks which are unavoidable in the case of wye-delta starters for instance do not occur.

#### Application areas

See "Selection aid for soft starters", page 6/6.



# SIRIUS 3RW Soft Starters

## 3RW30, 3RW40 for Standard Applications

3RW30

### Technical specifications

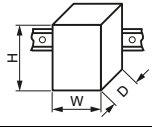
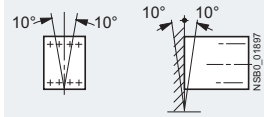
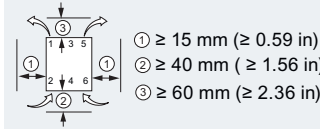
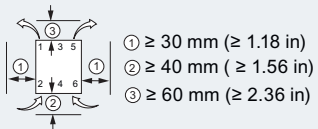
Type		3RW301.	3RW302.	3RW303.	3RW304.	
<b>Mechanics and environment</b>						
<b>Mounting dimensions (W x H x D)</b> • Screw terminals • Spring-type terminals		mm	45 x 95 x 151	45 x 125 x 151	55 x 144 x 168	70 x 160 x 186
		mm	45 x 117 x 151	45 x 150 x 151	55 x 144 x 168	70 x 160 x 186
<b>Permissible ambient temperature</b>						
Operation	°C	-25 ... +60; (derating from +40)				
Storage	°C	-40 ... +80				
<b>Weight</b>	kg	0.58	0.69	1.20	1.71	
<b>Permissible mounting position<sup>1)</sup></b> (auxiliary fan not available)						
						
<b>Installation type<sup>1)</sup></b> Stand-alone installation						
						
<b>Permissible installation altitude</b> m						
		5 000 (derating from 1000, see "Characteristic Curves" page 6/7); higher on request				
<b>Degree of protection</b>						
		IP20 for 3RW301. and 3RW302.; IP00 for 3RW303. and 3RW304.				

<sup>1)</sup> Please note derating information in case of deviations.  
See the Manual in Chapter "Configuration":  
<http://support.automation.siemens.com/WW/view/en/38752095>

Type		3RW301., 3RW302.	3RW303., 3RW304.			
<b>Control electronics</b>						
<b>Rated values</b> Rated control supply voltage • Tolerance	Terminal A1/A2	V	24	110 ... 230	24	110 ... 230
		%	±20	-15/+10	±20	-15/+10
Rated frequency • Tolerance		Hz	50/60			
		%	±10			

Type		3RW301.	3RW302.	3RW303.	3RW304.
<b>Power electronics</b>					
<b>Rated operational voltage</b> Tolerance	V AC	200 ... 480			
	%	-15/+10			
<b>Rated frequency</b> Tolerance	Hz	50/60			
	%	±10			
<b>Uninterrupted duty</b> at 40 °C (% of $I_e$ )	%	115			
<b>Minimum load</b> (% of $I_e$ )	%	10 (at least 2 A)			
<b>Maximum cable length</b> between soft starter and motor	m	300			

Type		3RW3013	3RW3014	3RW3016	3RW3017	3RW3018
<b>Power electronics</b>						
<b>Load rating with rated operational current <math>I_e</math></b> • According to IEC and UL/CSA <sup>1)</sup> , for individual mounting, AC-53a						
	A	3.6	6.5	9	12.5	17.6
- At 40 °C	A	3.3	6	8	12	17
- At 50 °C	A	3	5.5	7	11	14
- At 60 °C	A					
<b>Power loss</b>						
• In operation after completed starting with uninterrupted rated operational current (40 °C) approx. • During starting with 300 % $I_M$ (40 °C)	W	0.25	0.5	1	2	4
	W	24	52	80	80	116
<b>Permissible rated motor current and starts per hour for normal starting (CLASS 10) at 40 °C/50 °C</b>						
- Rated motor current $I_M^{(2)}$ , starting time 3 s - Starts per hour <sup>3)</sup>	A	3.6 / 3.3	6.5 / 6.0	9 / 8	12.5 / 12.0	17.6 / 17.0
	1/h	200 / 150	87 / 60	50 / 50	85 / 70	62 / 46
- Rated motor current $I_M^{(2)}$ , starting time 4 s - Starts per hour <sup>3)</sup>	A	3.6 / 3.3	6.5 / 6.0	9 / 8	12.5 / 12.0	17.6 / 17.0
	1/h	150 / 100	64 / 46	35 / 35	62 / 47	45 / 32

<sup>1)</sup> Measurement at 60 °C according to UL/CSA not required.

<sup>2)</sup> With 300 %  $I_M$ ,  $T_U = 40$  °C/50 °C.

<sup>3)</sup> For intermittent duty S4 with ON period = 30 %,  $T_U = 40$  °C/50 °C, stand-alone installation vertical. The quoted switching frequencies do not apply for automatic mode.

# SIRIUS 3RW Soft Starters

## 3RW30, 3RW40 for Standard Applications

### 3RW30

Type		3RW3026	3RW3027	3RW3028
<b>Power electronics</b>				
<b>Load rating with rated operational current <math>I_e</math></b>				
• According to IEC and UL/CSA <sup>1)</sup> , for individual mounting, AC-53a				
- At 40 °C	A	25.3	32.2	38
- At 50 °C	A	23	29	34
- At 60 °C	A	21	26	31
<b>Power loss</b>				
• In operation after completed starting with uninterrupted rated operational current (40 °C) approx.				
	W	8	13	19
• During starting with 300 % $I_M$ (40 °C)				
	W	188	220	256
<b>Permissible rated motor current and starts per hour for normal starting (CLASS 10) at 40 °C/50 °C</b>				
- Rated motor current $I_M$ <sup>2)</sup> , starting time 3 s				
	A	25 / 23	32 / 29	38 / 34
- Starts per hour <sup>3)</sup>				
	1/h	23 / 23	23 / 23	19 / 19
- Rated motor current $I_M$ <sup>2)</sup> , starting time 4 s				
	A	25 / 23	32 / 29	38 / 34
- Starts per hour <sup>3)</sup>				
	1/h	15 / 15	16 / 16	12 / 12

1) Measurement at 60 °C according to UL/CSA not required.

2) With 300 %  $I_M$ ,  $T_U = 40$  °C/50 °C.

3) For intermittent duty S4 with ON period = 30 %,  $T_U = 40$  °C/50 °C, stand-alone installation vertical. The quoted switching frequencies do not apply for automatic mode. Factors for permissible switching frequency with deviating mounting position, direct mounting, side-by-side mounting.

See the Manual in Chapter "Configuration":

<http://support.automation.siemens.com/WW/view/en/38752095>

Type		3RW3036	3RW3037	3RW3038	3RW3046	3RW3047
<b>Power electronics</b>						
<b>Load rating with rated operational current <math>I_e</math></b>						
• According to IEC and UL/CSA <sup>1)</sup> , for individual mounting, AC-53a						
- At 40 °C	A	45	65	72	80	106
- At 50 °C	A	42	58	62.1	73	98
- At 60 °C	A	39	53	60	66	90
<b>Power loss</b>						
• In operation after completed starting with uninterrupted rated operational current (40 °C) approx.						
	W	6	12	15	12	21
• During starting with 300 % $I_M$ (40 °C)						
	W	316	444	500	576	768
<b>Permissible rated motor current and starts per hour for normal starting (CLASS 10) at 40 °C/50 °C</b>						
- Rated motor current $I_M$ <sup>2)</sup> , starting time 3 s						
	A	45 / 42	63 / 58	72 / 62	80 / 73	106 / 108
- Starts per hour <sup>3)</sup>						
	1/h	38 / 38	23 / 23	22 / 22	22 / 22	15 / 15
- Rated motor current $I_M$ <sup>2)</sup> , starting time 4 s						
	A	45 / 42	63 / 58	72 / 62	80 / 73	106 / 98
- Starts per hour <sup>3)</sup>						
	1/h	26 / 26	15 / 15	15 / 15	15 / 15	10 / 10

1) Measurement at 60 °C according to UL/CSA not required.

2) With 300 %  $I_M$ ,  $T_U = 40$  °C/50 °C.

3) For intermittent duty S4 with ON period = 30 %,  $T_U = 40$  °C/50 °C, stand-alone installation vertical. The quoted switching frequencies do not apply for automatic mode.

# SIRIUS 3RW Soft Starters

## 3RW30, 3RW40 for Standard Applications

3RW30

Type		3RW3003-1CB54	3RW3003-2CB54
<b>Mechanics and environment</b>			
<b>Mounting dimensions (W x H x D)</b>		mm mm	22.5 x 100 x 120 -- 22.5 x 101.6 x 120
<ul style="list-style-type: none"> <li>Screw terminals</li> <li>Spring-type terminals</li> </ul>			
<b>Permissible ambient temperature</b>		°C	-25 ... +60; (derating from +40)
Operation		°C	-40 ... +80
Storage			
<b>Weight</b>	kg	0.207	0.188
<b>Permissible mounting position</b>			
<b>Permissible installation altitude</b>	m	5 000 (derating from 1 000, see "Characteristic Curves", page 6/7); higher on request	
<b>Degree of protection</b> acc. to IEC 60529		IP20 (IP00 terminal compartment)	
<b>Control electronics</b>			
<b>Rated values</b>			
Rated control supply voltage	V	24 ... 230 AC/DC	
• Tolerance	%	± 10	
Rated frequency at AC	Hz	50/60	
• Tolerance	%	± 10	
<b>Power electronics</b>			
<b>Rated operational voltage</b>	V AC	200 ... 400	
Tolerance	%	± 10	
<b>Rated frequency</b>	Hz	50/60	
Tolerance	%	± 10	
<b>Uninterrupted duty</b> (% of $I_e$ )	%	100	
<b>Minimum load<sup>1)</sup></b> (% of $I_e$ ); at 40 °C	%	9	
<b>Maximum conductor length</b> between soft starter and motor	m	100 <sup>2)</sup>	
<b>Load rating with rated operational current <math>I_e</math></b>			
• According to IEC and UL/CSA for individual mounting at 40/50/60 °C, AC-53a	A	3 / 2.6 / 2.2	
• According to IEC and UL/CSA for side-by-side-mounting at 40/50/60 °C, AC-53a	A	2.6 / 2.2 / 1.8	
<b>Power loss</b>			
• In operation after completed starting with uninterrupted rated operational current (40 °C) approx.	W	6.5	
• At utilization of maximum switching frequency	W	3	
<b>Permissible starts per hour (cannot be increased by using a fan)</b>			
• For intermittent duty S4 $T_U = 40$ °C, stand-alone installation vertical.	1/h	1 500	
• ON period = 70 % for 300 % $I_e$	1/s	0.2	
<b>Dead time after uninterrupted duty</b>			
With $I_e$ before restart	s	0	

<sup>1)</sup> The rated motor current (specified on the motor's name plate) should at least amount to the specified percentage of the SIRIUS soft starter unit's rated operational current  $I_e$ .

<sup>2)</sup> If this value is exceeded, problems with line capacities may arise, which can result in false firing.

# SIRIUS 3RW Soft Starters

## 3RW30, 3RW40 for Standard Applications

### 3RW30

#### Motor feeders with soft starters

The type of coordination according to which the motor feeder with soft starter is mounted depends on the application-specific requirements. Normally, fuseless mounting (combination of motor starter protector/circuit breaker and soft starter) is sufficient.

If type of coordination "2" is to be fulfilled, then semiconductor fuses must be fitted in the motor feeder.

T<sub>OC</sub> 1

Type of coordination "1" according to IEC 60947-4-1: After a short-circuit incident, the unit is defective and therefore unsuitable for further use (protection of persons and system guaranteed).

T<sub>OC</sub> 2

Type of coordination "2" according to IEC 60947-4-1: After a short-circuit incident the unit is suitable for further use (protection of persons and system guaranteed).

The type of coordination refers to soft starters in combination with the stipulated protective device (motor starter protector/circuit breaker/fuse), not to any additional components in the feeder.

The types of coordination are indicated in the corresponding tables by the symbols shown on orange backgrounds.

#### Fuseless version

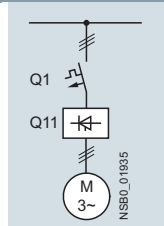

Soft starters		Motor starter protectors <sup>1)</sup>		
T <sub>OC</sub> 1	Nominal current	400 V + 10 %		Rated current
Q11 Type	A	Q1 Type	I <sub>q max</sub> kA	A
<b>Type of coordination "1"</b>				
<b>3RW3003</b>	3	3RV2011-1EA	50	4
<b>3RW3013</b>	3.6	3RV2011-1FA	5	5
<b>3RW3014</b>	6.5	3RV2011-1HA	5	8
<b>3RW3016</b>	9	3RV2011-1JA	5	10
<b>3RW3017</b>	12.5	3RV2011-1KA	5	12.5
<b>3RW3018</b>	17.6	3RV2021-4BA	5	20
<b>3RW3026</b>	25	3RV2021-4DA	55	25
<b>3RW3027</b>	32	3RV2021-4EA	55	32
<b>3RW3028</b>	38	3RV2021-4FA	55	40
<b>3RW3036</b>	45	3RV1031-4GA10	20	45
<b>3RW3037</b>	63	3RV1041-4JA10	20	63
<b>3RW3038</b>	72	3RV1041-4KA10	20	75
<b>3RW3046</b>	80	3RV1041-4LA10	11	90
<b>3RW3047</b>	106	3RV1041-4MA10	11	100

<sup>1)</sup> The rated motor current must be considered when selecting the devices.

# SIRIUS 3RW Soft Starters

## 3RW30, 3RW40 for Standard Applications

3RW30

### Fused version (line protection only)

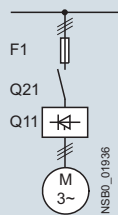

Soft starters T <sub>OC</sub> 1	Nominal current A	Line protection, maximum			Line contactors (optional)
		F1 Type	Rated current A	Size	
Q11 Type		F1 Type		Size	Q21 Type
<b>Type of coordination "1"<sup>1)</sup>: I<sub>q</sub> = 65 kA at 480 V + 10 %</b>					
<b>3RW3003<sup>2)</sup></b>	3	3NA3805 <sup>3)</sup>	20	000	3RT2015
<b>3RW3013</b>	3.6	3NA3803-6	10	000	3RT2015
<b>3RW3014</b>	6.5	3NA3805-6	16	000	3RT2015
<b>3RW3016</b>	9	3NA3807-6	20	000	3RT2016
<b>3RW3017</b>	12.5	3NA3810-6	25	000	3RT2018
<b>3RW3018</b>	17.6	3NA3814-6	35	000	3RT2026
<b>3RW3026</b>	25	3NA3822-6	63	00	3RT2026
<b>3RW3027</b>	32	3NA3824-6	80	00	3RT2027
<b>3RW3028</b>	38	3NA3824-6	80	00	3RT2028
<b>3RW3036</b>	45	3NA3130-6	100	1	3RT1036
<b>3RW3037</b>	63	3NA3132-6	125	1	3RT1044
<b>3RW3038</b>	72	3NA3132-6	125	1	3RT1045
<b>3RW3046</b>	80	3NA3136-6	160	1	3RT1045
<b>3RW3047</b>	106	3NA3136-6	160	1	3RT1046

<sup>1)</sup> The type of coordination "1" refers to soft starters in combination with the stipulated protective device (motor starter protector/circuit breaker/fuse), not to any additional components in the feeder.

<sup>2)</sup> I<sub>q</sub> = 50 kA at 400 V.

<sup>3)</sup> 3NA3805-1 (NH00), 5SB261 (DIAZED), 5SE2201-6 (NEOZED).

### Fused version with 3NE1 SITOR fuses (semiconductor and line protection)

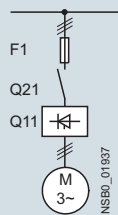

Matching fuse bases see  
 Catalog LV 10 → "Switch Disconnectors" and  
 Catalog LV 10 → "Fuse Systems"  
 → "SITOR Semiconductor Fuses"  
 or visit [www.siemens.com/sitor](http://www.siemens.com/sitor)

Soft starters T <sub>OC</sub> 2	Nominal current A	All-range fuses			Line contactors (optional)
		F1 Type	Rated current A	Size	
Q11 Type		F1 Type		Size	Q21 Type
<b>Type of coordination "2"<sup>1)</sup>: I<sub>q</sub> = 65 kA at 480 V + 10 %</b>					
<b>3RW3003<sup>2)</sup></b>	3	3NE1813-0 <sup>3)</sup>	16	000	3RT2015
<b>3RW3013</b>	3.6	3NE1813-0	16	000	3RT2015
<b>3RW3014</b>	6.5	3NE1813-0	16	000	3RT2015
<b>3RW3016</b>	9	3NE1813-0	16	000	3RT2016
<b>3RW3017</b>	12.5	3NE1813-0	16	000	3RT2018
<b>3RW3018</b>	17.6	3NE1814-0	20	000	3RT2026
<b>3RW3026</b>	25	3NE1803-0	35	000	3RT2026
<b>3RW3027</b>	32	3NE1020-2	80	00	3RT2027
<b>3RW3028</b>	38	3NE1020-2	80	00	3RT2028
<b>3RW3036</b>	45	3NE1020-2	80	00	3RT1036
<b>3RW3037</b>	63	3NE1820-0	80	000	3RT1044
<b>3RW3038</b>	72	3NE1820-0	80	000	3RT1045
<b>3RW3046</b>	80	3NE1021-0	100	00	3RT1045
<b>3RW3047</b>	106	3NE1022-0	125	00	3RT1046

<sup>1)</sup> The type of coordination "2" refers to soft starters in combination with the stipulated protective device (motor starter protector/circuit breaker/fuse), not to any additional components in the feeder.

<sup>2)</sup> I<sub>q</sub> = 50 kA at 400 V.

<sup>3)</sup> No SITOR fuse required!  
 Alternatively: 3NA3803 (NH00), 5SB221 (DIAZED), 5SE2206 (NEOZED).

# SIRIUS 3RW Soft Starters

## 3RW30, 3RW40 for Standard Applications

### 3RW30

Fused version with 3NE3 SITOR fuses (semiconductor protection by fuse, line and overload protection by motor starter protector; alternatively, installation with contactor and overload relay possible)

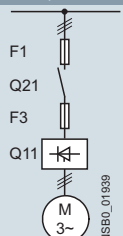
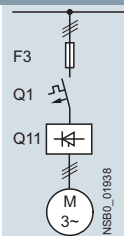

Matching fuse bases see  
 Catalog LV 10 → "Switch Disconnectors" and  
 Catalog LV 10 → "Fuse Systems"  
 → "SITOR Semiconductor Fuses"  
 or visit [www.siemens.com/sitor](http://www.siemens.com/sitor)

Soft starters Q11 Type	Nom. curr. A	Semiconductor fuses, minimum			Semiconductor fuses, maximum			Semiconductor fuses, minimum		
		F3 Type	Rated current A	Size	F3 Type	Rated current A	Size	F3 Type	Rated current A	Size
Type of coordination "2" <sup>1)</sup> : $I_q = 65 \text{ kA at } 480 \text{ V} + 10 \%$										
3RW3003 <sup>2)</sup>	3	--	--	--	--	--	--	--	--	--
3RW3013	3.6	--	--	--	--	--	--	3NE4101	32	0
3RW3014	6.5	--	--	--	--	--	--	3NE4101	32	0
3RW3016	9	--	--	--	--	--	--	3NE4101	32	0
3RW3017	12.5	--	--	--	--	--	--	3NE4101	32	0
3RW3018	17.6	--	--	--	3NE3221	100	1	3NE4101	32	0
3RW3026	25	--	--	--	3NE3221	100	1	3NE4102	40	0
3RW3027	32	--	--	--	3NE3222	125	1	3NE4118	63	0
3RW3028	38	--	--	--	3NE3222	125	1	3NE4118	63	0
3RW3036	45	--	--	--	3NE3224	160	1	3NE4120	80	0
3RW3037	63	--	--	--	3NE3225	200	1	3NE4121	100	0
3RW3038	72	3NE3221	100	1	3NE3227	250	1	--	--	--
3RW3046	80	3NE3222	125	1	3NE3225	200	1	--	--	--
3RW3047	106	3NE3224	160	1	3NE3231	350	1	--	--	--

Soft starters Q11 Type	Nom. curr. A	Semiconductor fuses max.			Semiconductor fuses min.			Semiconductor fuses max.			Cylindrical fuses	
		F3 Type	Rated current A	Size	F3 Type	Rated current A	Size	F3 Type	Rated current A	Size	F3 Type	Rated current A
Type of coordination "2" <sup>1)</sup> : $I_q = 65 \text{ kA at } 480 \text{ V} + 10 \%$												
3RW3003 <sup>2)</sup>	3	--	--	--	3NE8015-1	25	00	3NE8015-1	25	00	3NC1010	10
3RW3013	3.6	--	--	--	3NE8015-1	25	00	3NE8015-1	25	00	3NC2220	20
3RW3014	6.5	--	--	--	3NE8015-1	25	00	3NE8015-1	25	00	3NC2220	20
3RW3016	9	--	--	--	3NE8015-1	25	00	3NE8015-1	25	00	3NC2220	20
3RW3017	12.5	--	--	--	3NE8015-1	25	00	3NE8018-1	63	00	3NC2250	50
3RW3018	17.6	--	--	--	3NE8003-1	35	00	3NE8021-1	100	00	3NC2263	63
3RW3026	25	3NE4117	50	0	3NE8017-1	50	00	3NE8021-1	100	00	3NC2263	63
3RW3027	32	3NE4118	63	0	3NE8018-1	63	00	3NE8022-1	125	00	3NC2280	80
3RW3028	38	3NE4118	63	0	3NE8020-1	80	00	3NE8022-1	125	00	3NC2280	80
3RW3036	45	3NE4120	80	0	3NE8020-1	80	00	3NE8024-1	160	00	3NC2280	80
3RW3037	63	3NE4121	100	0	3NE8021-1	100	00	3NE8024-1	160	00	--	--
3RW3038	72	--	--	--	3NE8022-1	125	00	3NE8024-1	160	00	--	--
3RW3046	80	--	--	--	3NE8022-1	125	00	3NE8024-1	160	00	--	--
3RW3047	106	--	--	--	3NE8024-1	160	00	3NE8024-1	160	00	--	--

Soft starters Q11 Type	Nom. curr. A	Line contactors (optional) Q21	Motor starter protectors 400 V + 10 %		Line protection, maximum		
			Q1 Type	Rated current A	F1 Type	Rated current A	Size
Type of coordination "2" <sup>1)</sup> : $I_q = 65 \text{ kA at } 480 \text{ V} + 10 \%$							
3RW3003 <sup>2)</sup>	3	3RT2015	3RV2011-1EA	4	3NA3805 <sup>3)</sup>	20	000
3RW3013	3.6	3RT2015	3RV2011-1FA	5	3NA3803-6	10	000
3RW3014	6.5	3RT2015	3RV2011-1HA	8	3NA3805-6	16	000
3RW3016	9	3RT2016	3RV2011-1JA	10	3NA3807-6	20	000
3RW3017	12.5	3RT2018	3RV2011-1KA	12.5	3NA3810-6	25	000
3RW3018	17.6	3RT2026	3RV2021-4BA	20	3NA3814-6	35	000
3RW3026	25	3RT2026	3RV2021-4DA	25	3NA3822-6	63	00
3RW3027	32	3RT2027	3RV2021-4EA	32	3NA3824-6	80	00
3RW3028	38	3RT2028	3RV2021-4FA	40	3NA3824-6	80	00
3RW3036	45	3RT1036	3RV1031-4GA10	45	3NA3130-6	100	1
3RW3037	63	3RT1044	3RV1041-4JA10	63	3NA3132-6	125	1
3RW3038	72	3RT1045	3RV1041-4KA10	75	3NA3132-6	125	1
3RW3046	80	3RT1045	3RV1041-4LA10	90	3NA3136-6	160	1
3RW3047	106	3RT1046	3RV1041-4MA10	100	3NA3136-6	160	1

<sup>1)</sup> The type of coordination "2" refers to soft starters in combination with the stipulated protective device (motor starter protector/fuse), not to any additional components in the feeder.

<sup>2)</sup>  $I_q = 50 \text{ kA at } 400 \text{ V}$ .

<sup>3)</sup> 3NA3805-1 (NH00), 5SB261 (DIAZED).

# SIRIUS 3RW Soft Starters

## 3RW30, 3RW40 for Standard Applications

3RW30

### Selection and ordering data



3RW ambient temperature 40 °C				3RW ambient temperature 50 °C				Size	DT <sup>1)</sup>	Configurator	Article No.	Price per PU	PU (UNIT, SET, M)	PS*	PG
Rated values of three-phase motors				Rated values of three-phase motors											
Operational current $I_e$	Rating at operational voltage $U_e$			Operational current $I_e$	Rating at operational voltage $U_e$			hp	hp	hp	hp	A	kW	kW	kW
	230 V	400 V	500 V		200 V	230 V	460 V								
3.6	0.75	<b>1.5</b>	--	3	0.5	0.5	<b>1.5</b>	--	<b>S00</b>	A	<b>3RW3013-□BB□4</b>	1	1 unit	42G	
6.5	1.5	<b>3</b>	--	4.8	1	1	<b>3</b>	--	<b>S00</b>	A	<b>3RW3014-□BB□4</b>	1	1 unit	42G	
9	2.2	<b>4</b>	--	7.8	2	2	<b>5</b>	--	<b>S00</b>	A	<b>3RW3016-□BB□4</b>	1	1 unit	42G	
12.5	3	<b>5.5</b>	--	11	3	3	<b>7.5</b>	--	<b>S00</b>	A	<b>3RW3017-□BB□4</b>	1	1 unit	42G	
17.6	4	<b>7.5</b>	--	17	3	3	<b>10</b>	--	<b>S00</b>	A	<b>3RW3018-□BB□4</b>	1	1 unit	42G	
25	5.5	<b>11</b>	--	23	5	5	<b>15</b>	--	<b>S0</b>	A	<b>3RW3026-□BB□4</b>	1	1 unit	42G	
32	7.5	<b>15</b>	--	29	7.5	7.5	<b>20</b>	--	<b>S0</b>	A	<b>3RW3027-□BB□4</b>	1	1 unit	42G	
38	11	<b>18.5</b>	--	34	10	10	<b>25</b>	--	<b>S0</b>	A	<b>3RW3028-□BB□4</b>	1	1 unit	42G	
45	11	<b>22</b>	--	42	10	15	<b>30</b>	--	<b>S2</b>	A	<b>3RW3036-□BB□4</b>	1	1 unit	42G	
63	18.5	<b>30</b>	--	58	15	20	<b>40</b>	--	<b>S2</b>	A	<b>3RW3037-□BB□4</b>	1	1 unit	42G	
72	22	<b>37</b>	--	62	20	20	<b>40</b>	--	<b>S2</b>	A	<b>3RW3038-□BB□4</b>	1	1 unit	42G	
80	22	<b>45</b>	--	73	20	25	<b>50</b>	--	<b>S3</b>	A	<b>3RW3046-□BB□4</b>	1	1 unit	42G	
106	30	<b>55</b>	--	98	30	30	<b>75</b>	--	<b>S3</b>	A	<b>3RW3047-□BB□4</b>	1	1 unit	42G	

#### Article No. supplement for connection types

- With screw terminals
- With spring-type terminals<sup>2)</sup>

#### Article No. supplement for rated control supply voltage $U_s$

- 24 V AC/DC
- 110 ... 230 V AC/DC

#### Soft starters for easy starting conditions and high switching frequency, rated operational voltage $U_e$ 200 ... 400 V, rated control supply voltage $U_s$ 24 ... 230 V AC/DC

3	0.55	<b>1.1</b>	--	2.6	0.5	<b>0.5</b>	--	--	22.5 mm	▶	<b>3RW3003-1CB54</b>	1	1 unit	42G
										▶	<b>3RW3003-2CB54</b>	1	1 unit	42G

Online configurator see [www.siemens.com/sirius/configurators](http://www.siemens.com/sirius/configurators)

<sup>1)</sup> Soft starter with screw terminals: delivery time class ▶ (preferred type).

<sup>2)</sup> Main circuit connection: screw terminals.

#### Note:

The listed motor ratings are rough guide values. The soft starter should always be designed on the basis of the required rated operational current of the motor.

The SIRIUS 3RW30 solid-state soft starters are designed for easy starting conditions. The selection and ordering data were determined for the following boundary conditions (see also the notes on page 6/6):



- Maximum starting time in s: 3
- Maximum starting current in % of motor current  $I_e$ : 300
- Maximum number of starts per hour in 1/h: 20
- Stand-alone installation (side-by-side see manual, <http://support.automation.siemens.com/WWW/view/en/38752095>)

# SIRIUS 3RW Soft Starters

## 3RW30, 3RW40 for Standard Applications

### 3RW30

#### Accessories

Conductor cross-section		Tightening torque	For soft starters size	DT	Article No.	Price per PU	PU (UNIT, SET, M)	PS*	PG	
Solid or stranded	Finely stranded with end sleeve									AWG cables, solid or stranded
mm <sup>2</sup>	mm <sup>2</sup>	AWG	Nm							
<b>Three-phase infeed terminals</b>										
	2.5 ... 25	2.5 ... 16	10 ... 4	3 ... 4	S00 (3RW301.)		1	1 unit	41E	
					S0 (3RW302.)					
<b>Auxiliary terminals</b>										
For soft starters				DT	Article No.	Price per PU	PU (UNIT, SET, M)	PS*	PG	
Type	Size									
<b>Auxiliary terminals, 3-pole</b>										
3RW304.	<b>S3</b>			B	<b>3RT1946-4F</b>		1	1 unit	41B	
<b>Covers for soft starters</b>										
<b>Terminal covers for box terminals</b>										
Additional touch protection to be fitted at the box terminals (2 units required per device)										
3RW303.	<b>S2</b>			B	<b>3RT1936-4EA2</b>		1	1 unit	41B	
3RW304.	<b>S3</b>			B	<b>3RT1946-4EA2</b>		1	1 unit	41B	
<b>Terminal cover for cable lugs and busbar connections</b>										
For complying with the voltage clearances and as touch protection if box terminal is removed (2 units required per device)										
	3RW304.	<b>S3</b>			B	<b>3RT1946-4EA1</b>		1	1 unit	41B
3RT1946-4EA1										
<b>Manual 3RW30/3RW40<sup>1)</sup></b>										

<sup>1)</sup> The operating instructions for 3RW30 (3ZX1012-0RW30-2DA1) are included in the scope of supply of the soft starter or are available – like the manual – as a PDF download from the Service&Support portal at [www.siemens.com/industrial-controls/support](http://www.siemens.com/industrial-controls/support). Search the section "Switching Devices" → "Soft Starters and Solid-State Switching Devices" → "SIRIUS 3RW Soft Starters".



# SIRIUS 3RW Soft Starters

## 3RW30, 3RW40 for Standard Applications

3RW30

For soft starters	Motor starter protectors	DT	Article No.	Price per PU	PU (UNIT, SET, M)	PS*	PG
Type	Size	Size					

### Link modules to motor starter protectors<sup>1)</sup>

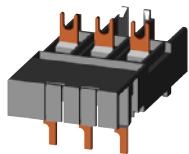

3RA2921-1BA00

#### • With screw terminals

3RW301.	<b>S00</b>	<b>S00</b>	A	<b>3RA2921-1BA00</b>	1	1 unit	41B
3RW302.	<b>S0</b>	<b>S00/S0</b>	A	<b>3RA2921-1BA00</b>	1	1 unit	41B
3RW3036.	<b>S2</b>	<b>S2</b>	▶	<b>3RA1931-1AA00</b>	1	1 unit	41B
3RW3046, 3RW3047.	<b>S3</b>	<b>S3</b>	▶	<b>3RA1941-1AA00</b>	1	1 unit	41B

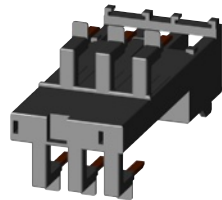

3RA2921-2GA00

#### • With spring-type terminals

3RW301.	<b>S00</b>	<b>S00</b>	▶	<b>3RA2911-2GA00</b>	1	1 unit	41B
3RW302.	<b>S0</b>	<b>S0</b>	▶	<b>3RA2921-2GA00</b>	1	1 unit	41B

- <sup>1)</sup> Can be used in size S0 up to maximum 32 A.  
Can be used in size S00/S0 only for 3RV2 motor starter protectors.

Version	Functionality Functions	Use	DT	Article No.	Price per PU	PU (UNIT, SET, M)	PS*	PG
---------	-------------------------	-----	----	-------------	--------------	-------------------	-----	----

### Covers and push-in lugs (only for 3RW30 03)



3RP1902

<b>Sealable covers</b>	For securing against unauthorized adjustment of setting knobs	For devices with 1 or 2 CO contacts	B	<b>3RP1902</b>	1	5 units	41H
------------------------	---	-------------------------------------	---	----------------	---	---------	-----



3RP1903

<b>Push-in lugs</b>	For screw fixings	For devices with 1 or 2 CO contacts	B	<b>3RP1903</b>	1	10 units	41H
---------------------	-------------------	-------------------------------------	---	----------------	---	----------	-----

Version	DT	Article No.	Price per PU	PU (UNIT, SET, M)	PS*	PG
---------	----	-------------	--------------	-------------------	-----	----

### Tool for opening spring-type terminals in sizes S00 and S0



3RA2908-1A

**Screwdrivers**  
For all SIRIUS devices with spring-type terminals length approx. 200 mm, 3.0 mm x 0.5 mm, titanium gray/black, partially insulated

#### Spring-type terminals



A	<b>3RA2908-1A</b>	1	1 unit	41B
---	-------------------	---	--------	-----

### Blank labels

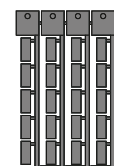

3RT2900-1SB20

#### Unit labeling plates<sup>1)</sup>

For SIRIUS devices

• 20 mm x 7 mm, titanium gray	D	<b>3RT2900-1SB20</b>	100	340 units	41B
-------------------------------	---	----------------------	-----	-----------	-----

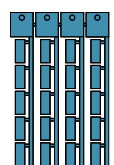

3RT1900-1SB20

• 20 mm x 7 mm, pastel turquoise	D	<b>3RT1900-1SB20</b>	100	340 units	41B
----------------------------------	---	----------------------	-----	-----------	-----

- <sup>1)</sup> PC labeling systems for individual inscription of unit labeling plates are available from: murrplastik Systemtechnik GmbH (see Chapter 16, "Appendix" → "External Partners").

# SIRIUS 3RW Soft Starters

## 3RW30, 3RW40 for Standard Applications

### 3RW30

#### More information

#### Application examples for normal starting (CLASS 10)

**Normal starting CLASS 10** (up to 20 s with 300%  $I_{n \text{ motor}}$ , one start per hour)  
The soft starter rating can be selected to be as high as the rating of the motor used

Application		Conveyor belts	Roller conveyors	Compressors	Small fans <sup>1)</sup>	Pumps	Hydraulic pumps
<b>Starting parameters</b>							
• Voltage ramp and current limiting							
- Starting voltage	%	70	60	50	40	40	40
- Starting time	s	10	10	20	20	10	10

<sup>1)</sup> The mass inertia of the fan is <10 times the mass inertia of the motor.

#### Note:

These tables present sample set values and device dimensions. They are intended only for the purposes of information and are not binding. The set values depend on the application in question and must be optimized during commissioning.

The soft starter dimensions should be checked where necessary with the help of Technical Assistance.

#### Configuration

The 3RW solid-state motor controllers are designed for easy starting conditions. In the event of deviating conditions or increased switching frequency, it may be necessary to choose a larger device.

If necessary, an overload relay for heavy starting must be selected where long starting times are involved. PTC sensors are recommended.

No capacitive elements are permitted in the motor feeder between the SIRIUS 3RW soft starter and the motor (e.g. no reactive-power compensation equipment). In addition, neither static systems for reactive-power compensation nor dynamic PFC (Power Factor Correction) must be operated in parallel during starting and ramp-down of the soft starter. This is important to prevent faults arising on the compensation equipment and/or the soft starter.

All elements of the main circuit (such as fuses, controls and overload relays) should be dimensioned for direct starting, following the local short-circuit conditions. Fuses, controls and overload relays must be ordered separately. Please observe the maximum switching frequencies specified in the technical specifications.

#### Note:

When three-phase motors are switched on, voltage drops occur as a rule on starters of all types (direct-on-line starters, wye-delta starters, soft starters). The infeed transformer must always be dimensioned such that the voltage dip when starting the motor remains within the permissible tolerance. If the infeed transformer is dimensioned with only a small margin, it is best for the control voltage to be supplied from a separate circuit (independently of the main voltage) in order to avoid the potential switching off of the soft starter.

#### Schematic circuit diagram of power electronics

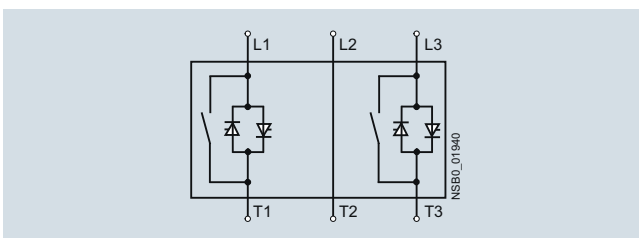

A bypass contact system is already integrated in the 3RW30 soft starter and therefore does not have to be ordered separately.

#### Status graphs

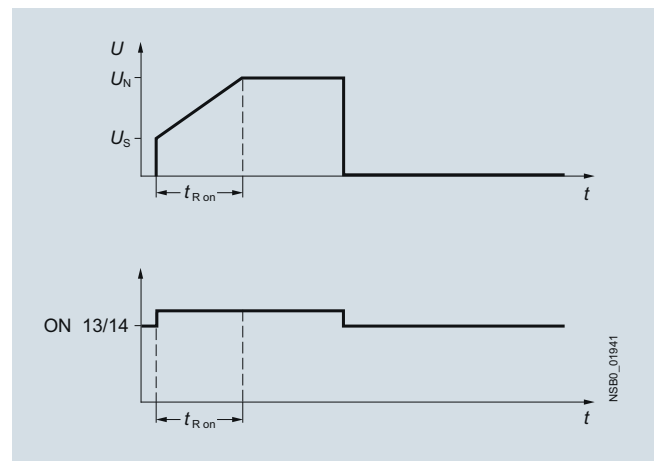

#### Manual for SIRIUS 3RW30/40

In addition to relevant configuration, commissioning, and service information, the manual also contains example circuits and technical specifications for all devices:

<http://support.automation.siemens.com/WW/view/en/38752095>

# SIRIUS 3RW Soft Starters

## 3RW30, 3RW40 for Standard Applications

3RW40

### Overview

SIRIUS 3RW40 soft starters have all the same advantages as the 3RW30 soft starters.

The SIRIUS 3RW40 soft starters are characterized above all by their small space requirements. Integrated bypass contacts mean that no power loss has to be taken into the bargain at the power semiconductors (thyristors) after the motor has started up. This cuts down on heat losses, enabling a more compact design and making external bypass circuits superfluous.

At the same time this soft starter comes with additional integrated functions such as adjustable current limiting, motor overload and intrinsic device protection, and optional thermistor motor protection. The higher the motor rating, the more important these functions because they make it unnecessary to purchase and install protection equipment such as overload relays.

Internal intrinsic device protection prevents the thermal overloading of the thyristors and the power section defects this can cause. As an option the thyristors can also be protected by semiconductor fuses from short-circuiting.

Thanks to integrated status monitoring and fault monitoring, this compact soft starter offers many different diagnostics options. Up to four LEDs and relay outputs permit differentiated monitoring and diagnostics of the operating mechanism by indicating the operating state as well as for example mains or phase failure, missing load, non-permissible tripping time/CLASS setting, thermal overloading or device faults.

Soft starters rated up to 250 kW (at 400 V) for standard applications in three-phase networks are available. Extremely small sizes, low power losses and simple start-up are just three of the many advantages of the SIRIUS 3RW40 soft starters.

#### **"Increased safety" type of protection EEx e according to ATEX directive 94/9/EC**

The 3RW40 soft starter sizes S0 to S12 are suitable for the starting of explosion-proof motors with "increased safety" type of protection EEx e.

#### **Functionality**

The space required by the compact SIRIUS 3RW40 soft starter is often only about one third of that required by a contactor assembly for wye-delta starting of comparable rating. This not only saves space in the control cabinet and on the standard mounting rail but also does away completely with the wiring work needed for wye-delta starters. This is notable in particular for higher motor ratings which are only rarely available as fully wired solutions.

At the same time the number of cables from the starter to the motor is reduced from six to three. Compact dimensions, short start-up times, easy wiring and fast commissioning make themselves felt as clear-cut cost advantages.

The bypass contacts of these soft starters are protected during operation by an integrated solid-state arc quenching system. This prevents damage to the bypass contacts in the event of a fault, e.g. brief disconnection of the control voltage, mechanical shocks or life-related component defects on the coil operating mechanism or main contact spring.

The starting current of particularly powerful operating mechanisms can place an unjustifiable load on the local supply system. Soft starters reduce this starting current by means of their voltage ramp. Thanks to the adjustable current limiting, the SIRIUS 3RW40 soft starter takes even more pressure off the supply system. It leaves the set start ramp during the ramp-up – the ramp gradient is fixed by the starting voltage and the ramp time – as soon as the selected current limit is reached. From this moment the voltage of the soft starter is controlled so that the current supplied to the motor remains constant. This process is ended either by completion of the motor ramp-up or by tripping by the intrinsic device protection or the motor overload protection. As the result of this function the actual motor ramp-up can well take longer than the ramp time selected on the soft starter.

Thanks to the integrated motor overload protection according to IEC 60947-4-2, there is no need for an additional overload relay on the new soft starters. The rated motor current, the setting of the overload tripping time (CLASS times) and the reset of the motor overload protection function can be adjusted easily and quickly. Using a 4-step rotary potentiometer it is possible to set different overload tripping times on the soft starter. In addition to CLASS 10, 15 and 20 it is also possible to switch off the motor overload protection if a different motor management control device is to be used for this function, e.g. with connection to PROFIBUS.

Device versions with thermistor motor protection evaluation are available up to a rating of 55 kW (at 400 V). A "Thermoclick" measuring probe can be connected directly, as can a PTC of type A. Thermal overloading of the motor, open circuits and short circuits in the sensor circuit all result in the direct disconnection of the soft starter. And if ever the soft starter trips, various reset options are available the same as with intrinsic device protection and motor load protection: manually with the reset button, automatically or remotely through brief disconnection of the control voltage.

The new series of devices comes with the "polarity balancing" control method, which is designed to prevent direct current components in two-phase controlled soft starters. On two-phase controlled soft starters the current resulting from superimposition of the two controlled phases flows in the uncontrolled phase. This results for physical reasons in an asymmetric distribution of the three phase currents during the motor ramp-up. This phenomenon cannot be influenced, but in most applications it is non-critical.

Controlling the power semiconductors results not only in this asymmetry, however, but also in the previously mentioned direct current components which can cause severe noise generation on the motor at starting voltages of less than 50 %.

The control method used for these soft starters eliminates these direct current components during the ramp-up phase and prevents the braking torque which they can cause. It creates a motor ramp-up that is uniform in speed, torque and current rise, thus permitting a particularly gentle, two-phase starting of the motors. At the same time the acoustic quality of the starting operation comes close to the quality of a three-phase controlled soft starter. This is made possible by the on-going dynamic harmonizing and balancing of current half-waves of different polarity during the motor ramp-up. Hence the name "polarity balancing".

### Application

The SIRIUS 3RW40 solid-state soft starters are used for the soft starting and stopping of three-phase asynchronous motors.

Due to two-phase control, the current is kept at minimum values in all three phases throughout the entire starting time and disturbing direct current components are eliminated in addition. This not only enables the two-phase starting of motors up to 250 kW (at 400 V) but also avoids the current and torque peaks which occur e.g. with wye-delta starters.

#### **Application areas**

See "Selection aid for soft starters" on page 6/6.

# SIRIUS 3RW Soft Starters

## 3RW30, 3RW40 for Standard Applications

### 3RW40

#### Technical specifications

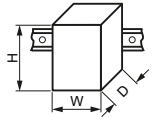
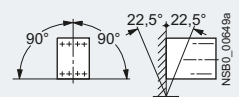
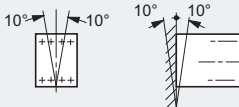
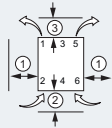
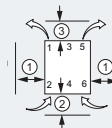
Type		3RW402.	3RW403.	3RW404.	3RW405.	3RW407.
<b>Mechanics and environment</b>						
<b>Mounting dimensions (W x H x D)</b>						
<ul style="list-style-type: none"> <li>Screw terminals</li> <li>Spring-type terminals</li> </ul>	mm	45 x 125 x 154	55 x 144 x 170	70 x 160 x 188	120 x 198 x 250	160 x 230 x 278
	mm	45 x 150 x 154	55 x 144 x 170	70 x 160 x 188	120 x 198 x 250	160 x 230 x 278
						
<b>Permissible ambient temperature</b>						
Operation	°C	-25 ... +60; (derating from +40)				
Storage	°C	-40 ... +80				
<b>Weight</b>						
	kg	0.77	1.35	1.9	4.9 (.55.) 6.9 (.56.)	8.9
<b>Permissible mounting position<sup>1)</sup></b>						
<ul style="list-style-type: none"> <li>With auxiliary fan (for 3RW402. ... 3RW404.)</li> </ul>						
	<ul style="list-style-type: none"> <li>Without auxiliary fan (for 3RW402. ... 3RW404.)</li> </ul>					
-- (fan integrated in the soft starter)						
<b>Installation type<sup>1)</sup></b>						
Stand-alone installation		3RW402.			3RW405., 3RW407.	
					<ul style="list-style-type: none"> <li>① ≥ 15 mm (≥ 0.59 in)</li> <li>② ≥ 40 mm (≥ 1.56 in)</li> <li>③ ≥ 60 mm (≥ 2.36 in)</li> </ul>	
		3RW403., 3RW404.			<ul style="list-style-type: none"> <li>① ≥ 5 mm (≥ 0.2 in)</li> <li>② ≥ 75 mm (≥ 3 in)</li> <li>③ ≥ 100 mm (≥ 4 in)</li> </ul>	
					<ul style="list-style-type: none"> <li>① ≥ 30 mm (≥ 1.18 in)</li> <li>② ≥ 40 mm (≥ 1.56 in)</li> <li>③ ≥ 60 mm (≥ 2.36 in)</li> </ul>	
<b>Permissible installation altitude</b>						
	m	5 000 (derating from 1000, see "Characteristic Curves" page 6/7); higher on request				
<b>Degree of protection</b>						
IP20 for 3RW402.; all others IP00						

<sup>1)</sup> Please note derating information in case of deviations.  
See the Manual in Chapter "Configuration":  
<http://support.automation.siemens.com/WW/view/en/38752095>

Type		3RW402., 3RW403., 3RW404.	3RW405., 3RW407.
<b>Control electronics</b>			
<b>Rated values</b>			
Rated control supply voltage	Terminal A1/A2	24 DC/AC	115 AC 230 AC
• Tolerance	V	±20	-15/+10
Rated frequency	Hz	50/60	
• Tolerance	%	±10	
<b>Power electronics</b>			
<b>Rated operational voltage</b>			
Tolerance	V AC	200 ... 480	200 ... 460
	%	-15/+10	-15/+10
<b>Maximum blocking voltage (thyristor)</b>			
	V AC	1 600	1 400
<b>Rated frequency</b>			
Tolerance	Hz	50/60	
	%	±10	
<b>Uninterrupted duty at 40 °C (% of I<sub>e</sub>)</b>			
	%	115	
<b>Minimum load (% of minimum selectable rated motor current I<sub>M</sub>)</b>			
	%	20 (at least 2 A)	
<b>Maximum cable length between soft starter and motor</b>			
	m	300	

# SIRIUS 3RW Soft Starters

## 3RW30, 3RW40 for Standard Applications

3RW40

Type		3RW4024	3RW4026	3RW4027	3RW4028
<b>Power electronics</b>					
<b>Load rating with rated operational current <math>I_e</math></b>					
• According to IEC and UL/CSA <sup>1)</sup> , for individual mounting, AC-53a					
- At 40 °C	A	12.5	25.3	32.2	38
- At 50 °C	A	11	23	29	34
- At 60 °C	A	10	21	26	31
<b>Smallest adjustable rated motor current <math>I_M</math></b>					
For the motor overload protection					
	A	5	10	17	23
<b>Power loss</b>					
• In operation after completed starting with uninterrupted rated operational current (40 °C) approx.					
	W	2	8	13	19
• During starting with current limit set to 300 % $I_M$ (40 °C)					
	W	68	188	220	256
<b>Permissible rated motor current and starts per hour at 40 °C / 50 °C</b>					
<b>• For normal starting (CLASS 10)</b>					
- Rated motor current $I_M^{(2)}$ , starting time 3 s	A	12.5 / 11	25 / 23	32 / 29	38 / 34
- Starts per hour <sup>3)</sup>	1/h	50 / 50	23 / 23	23 / 23	19 / 19
- Rated motor current $I_M^{(2)}$ , starting time 4 s	A	12.5 / 11	25 / 23	32 / 29	38 / 34
- Starts per hour <sup>3)</sup>	1/h	36 / 36	15 / 15	16 / 16	12 / 12
<b>• For heavy starting (CLASS 15)</b>					
- Rated motor current $I_M^{(2)}$ , starting time 4.5 s	A	11 / 10	23 / 21	30 / 27	34 / 31
- Starts per hour <sup>3)</sup>	1/h	49 / 49	21 / 21	18 / 18	18 / 18
- Rated motor current $I_M^{(2)}$ , starting time 6 s	A	11 / 10	23 / 21	30 / 27	34 / 31
- Starts per hour <sup>3)</sup>	1/h	36 / 36	14 / 14	13 / 13	13 / 13
<b>• For heavy starting (CLASS 20)</b>					
- Rated motor current $I_M^{(2)}$ , starting time 6 s	A	10 / 9	21 / 19	27 / 24	31 / 28
- Starts per hour <sup>3)</sup>	1/h	47 / 47	21 / 21	20 / 20	18 / 18
- Rated motor current $I_M^{(2)}$ , starting time 8 s	A	10 / 9	21 / 19	27 / 24	31 / 28
- Starts per hour <sup>3)</sup>	1/h	34 / 34	15 / 15	14 / 14	13 / 13

1) Measurement at 60 °C according to UL/CSA not required.

2) Current limit on soft starter set to 300 %  $I_M$ ,  $T_u = 40$  °C/50 °C. Maximum adjustable rated motor current  $I_M$  dependent on CLASS setting.

3) For intermittent duty S4 with ON period = 30 %,  $T_u = 40$  °C/50 °C, stand-alone installation vertical. The quoted switching frequencies do not apply for automatic mode. Factors for permissible switching frequency in other mounting position, direct mounting, side-by-side mounting, and implementation of optional auxiliary fan. See the Manual in Chapter "Configuration": <http://support.automation.siemens.com/WW/view/en/38752095>

Type		3RW4036	3RW4037	3RW4038	3RW4046	3RW4047
<b>Power electronics</b>						
<b>Load rating with rated operational current <math>I_e</math></b>						
• According to IEC and UL/CSA <sup>1)</sup> , for individual mounting, AC-53a						
- At 40 °C	A	45	63	72	80	106
- At 50 °C	A	42	58	62.1	73	98
- At 60 °C	A	39	53	60	66	90
<b>Smallest adjustable rated motor current <math>I_M</math></b>						
For the motor overload protection						
	A	23	26	35	43	46
<b>Power loss</b>						
• In operation after completed starting with uninterrupted rated operational current (40 °C) approx.						
	W	6	12	15	12	21
• During starting with current limit set to 300 % $I_M$ (40 °C)						
	W	316	444	500	576	768
<b>Permissible rated motor current and starts per hour at 40 °C / 50 °C</b>						
<b>• For normal starting (CLASS 10)</b>						
- Rated motor current $I_M^{(2)}$ , starting time 3 s	A	45 / 42	63 / 58	72 / 62	80 / 73	106 / 98
- Starts per hour <sup>3)</sup>	1/h	38 / 38	23 / 23	22 / 22	22 / 22	15 / 15
- Rated motor current $I_M^{(2)}$ , starting time 4 s	A	45 / 42	63 / 58	72 / 62	80 / 73	106 / 98
- Starts per hour <sup>3)</sup>	1/h	26 / 26	15 / 15	15 / 15	15 / 15	10 / 10
<b>• For heavy starting (CLASS 15)</b>						
- Rated motor current $I_M^{(2)}$ , starting time 4.5 s	A	42 / 38	50 / 46	56 / 52	70 / 64	84 / 77
- Starts per hour <sup>3)</sup>	1/h	30 / 30	34 / 34	34 / 34	24 / 24	23 / 23
- Rated motor current $I_M^{(2)}$ , starting time 6 s	A	42 / 38	50 / 46	56 / 52	70 / 64	84 / 77
- Starts per hour <sup>3)</sup>	1/h	21 / 21	24 / 24	24 / 24	16 / 16	17 / 17
<b>• For heavy starting (CLASS 20)</b>						
- Rated motor current $I_M^{(2)}$ , starting time 6 s	A	38 / 34	46 / 42	50 / 46	64 / 58	77 / 70
- Starts per hour <sup>3)</sup>	1/h	30 / 30	31 / 31	34 / 34	23 / 23	23 / 23
- Rated motor current $I_M^{(2)}$ , starting time 8 s	A	38 / 34	46 / 42	50 / 46	64 / 58	77 / 70
- Starts per hour <sup>3)</sup>	1/h	21 / 21	22 / 22	24 / 24	16 / 16	16 / 16

1) Measurement at 60 °C according to UL/CSA not required.

2) Current limit on soft starter set to 300 %  $I_M$ ,  $T_u = 40$  °C/50 °C. Maximum adjustable rated motor current  $I_M$  dependent on CLASS setting.

3) For intermittent duty S4 with ON period = 30 %,  $T_u = 40$  °C/50 °C, stand-alone installation vertical. The quoted switching frequencies do not apply for automatic mode. Factors for permissible switching frequency in other mounting position, direct mounting, side-by-side mounting, and implementation of optional auxiliary fan. See the Manual in Chapter "Configuration": <http://support.automation.siemens.com/WW/view/en/38752095>

# SIRIUS 3RW Soft Starters

## 3RW30, 3RW40 for Standard Applications

### 3RW40

Type		3RW4055	3RW4056	3RW4073	3RW4074	3RW4075	3RW4076
<b>Power electronics</b>							
<b>Load rating with rated operational current <math>I_o</math></b>							
• According to IEC and UL/CSA <sup>1)</sup> , for individual mounting, AC-53a							
- At 40 °C	A	134	162	230	280	356	432
- At 50 °C	A	117	145	205	248	315	385
- At 60 °C	A	100	125	180	215	280	335
<b>Smallest adjustable rated motor current <math>I_M</math></b>							
For the motor overload protection							
	A	59	87	80	130	131	207
<b>Power loss</b>							
• In operation after completed starting with uninterrupted rated operational current (40 °C) approx.							
	W	60	75	75	90	125	165
• During starting with current limit set to 350 % <sup>2)</sup> $I_M$ (40 °C)							
	W	1043	1355	2448	3257	3277	3600
<b>Permissible rated motor current and starts per hour at 40 °C / 50 °C</b>							
<b>• For normal starting (CLASS 10)</b>							
- Rated motor current $I_M$ <sup>2)</sup> , starting time 10 s	A	134 / 117	162 / 145	230 / 205	280 / 248	356 / 315	432 / 385
- Starts per hour <sup>3)</sup>	1/h	20 / 20	8 / 8	14 / 14	20 / 20	16 / 16	17 / 17
- Rated motor current $I_M$ <sup>2)</sup> , starting time 20 s	A	134 / 117	162 / 145	230 / 205	280 / 248	356 / 315	432 / 385
- Starts per hour <sup>3)</sup>	1/h	7 / 7	1.4 / 1.4	3 / 3	8 / 8	5 / 5	5 / 5
<b>• For heavy starting (CLASS 15)</b>							
- Rated motor current $I_M$ <sup>2)</sup> , starting time 15 s	A	134 / 117	152 / 140	210 / 200	250 / 220	341 / 315	402 / 385
- Starts per hour <sup>3)</sup>	1/h	11 / 11	8 / 8	11 / 11	13 / 13	11 / 11	12 / 12
- Rated motor current $I_M$ <sup>2)</sup> , starting time 30 s	A	134 / 117	152 / 140	210 / 200	250 / 220	341 / 315	402 / 385
- Starts per hour <sup>3)</sup>	1/h	1.2 / 1.2	1.7 / 1.7	1 / 1	6 / 6	2 / 2	2 / 2
<b>• For heavy starting (CLASS 20)</b>							
- Rated motor current $I_M$ <sup>2)</sup> , starting time 20 s	A	124 / 112	142 / 132	200 / 185	230 / 205	311 / 280	372 / 340
- Starts per hour <sup>3)</sup>	1/h	12 / 12	9 / 9	10 / 10	10 / 10	10 / 10	10 / 10
- Rated motor current $I_M$ <sup>2)</sup> , starting time 40 s	A	124 / 112	142 / 132	200 / 185	230 / 205	311 / 280	372 / 340
- Starts per hour <sup>3)</sup>	1/h	2 / 2	2 / 2	1 / 1	5 / 5	1 / 1	1 / 1

<sup>1)</sup> Measurement at 60 °C according to UL/CSA not required.

<sup>2)</sup> Current limit on soft starter set to 350 %  $I_M$ ,  $T_u = 40$  °C/50 °C. Maximum adjustable rated motor current  $I_M$  dependent on CLASS setting.

<sup>3)</sup> For intermittent duty S4 with ON period = 70 %,  $T_u = 40$  °C/50 °C, stand-alone installation vertical. The quoted switching frequencies do not apply for automatic mode.

# SIRIUS 3RW Soft Starters

## 3RW30, 3RW40 for Standard Applications

3RW40

### Motor feeders with soft starters

The type of coordination according to which the motor feeder with soft starter is mounted depends on the application-specific requirements. Normally, fuseless mounting (combination of motor starter protector and soft starter) is sufficient.

If type of coordination "2" is to be fulfilled, then semiconductor fuses must be fitted in the motor feeder.

T<sub>oc</sub> 1

Type of coordination "1" according to IEC 60947-4-1: After a short-circuit incident, the unit is defective and therefore unsuitable for further use (protection of persons and system guaranteed).

T<sub>oc</sub> 2

Type of coordination "2" according to IEC 60947-4-1: After a short-circuit incident the unit is suitable for further use (protection of persons and system guaranteed).

The type of coordination refers to soft starters in combination with the stipulated protective device (motor starter protector/circuit breaker/fuse), not to any additional components in the feeder.

The types of coordination are indicated in the corresponding tables by the symbols shown on orange backgrounds.

### Fuseless version

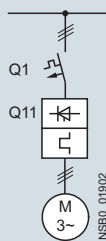

Soft starters		Motor starter protectors <sup>1)</sup>								
T <sub>oc</sub> 1	Nominal current	400 V + 10 %		400 V + 10 %		575 V + 10 %		575 V + 10 %		
Q11	A	Q1	Q1	I <sub>q max</sub>	Rated current	Q1	I <sub>q max</sub>	Rated current	Rated current	
Type	A	Type	Type	kA	A	Type	kA	A	A	
<b>Type of coordination "1"</b>										
<b>3RW4024</b>	12.5	3RV2021-4AA/ 3RV2011-4AA (in size S00)	3RV2321-4AC/ 3RV2311-4AC (in size S00)	55	16	--	--	--	--	
<b>3RW4026</b>	25	3RV2021-4DA	3RV2321-4DC	55	25	--	--	--	--	
<b>3RW4027</b>	32	3RV2021-4EA	3RV2321-4EC	55	32	--	--	--	--	
<b>3RW4028</b>	38	3RV2021-4FA	3RV2321-4FC	55	40	--	--	--	--	
<b>3RW4036</b>	45	3RV1031-4GA10	3RV1331-4GC10	20	45	--	--	--	--	
<b>3RW4037</b>	63	3RV1041-4JA10	3RV1341-4JC10	20	63	--	--	--	--	
<b>3RW4038</b>	72	3RV1041-4KA10	3RV1341-4KC10	20	75	--	--	--	--	
<b>3RW4046</b>	80	3RV1041-4LA10	3RV1341-4LC10	11	90	--	--	--	--	
<b>3RW4047</b>	106	3RV1041-4MA10	3RV1341-4MC10	11	100	--	--	--	--	
<b>3RW4055</b>	134	3VL3720-2DC36	--	35	200	3VL3720-1DC36	12	200		
<b>3RW4056</b>	162	3VL3720-2DC36	--	35	200	3VL3720-1DC36	12	200		
<b>3RW4073</b>	230	3VL4731-2DC36	--	65	315	3VL5731-3DC36	35	315		
<b>3RW4074</b>	280	3VL4731-2DC36	--	65	315	3VL5731-3DC36	35	315		
<b>3RW4075</b>	356	3VL4740-2DC36	--	65	400	3VL5740-3DC36	35	400		
<b>3RW4076</b>	432	3VL5750-2DC36	--	65	500	3VL5750-3DC36	35	500		

<sup>1)</sup> The rated motor current must be considered when selecting the devices. 3RV13/3RV23 motor starter protectors are designed for starter combinations (without motor protection). Motor protection is provided in this case by the 3RW40 soft starter.

# SIRIUS 3RW Soft Starters

## 3RW30, 3RW40 for Standard Applications

### 3RW40

#### Fused version (line protection only)

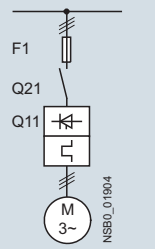

Soft starters	Nominal current	Line protection, maximum	Rated current	Size	Line contactors (optional)
Q11 Type	A	F1 Type	A		Q21 Type
<b>Type of coordination "1"<sup>1)</sup>: <math>I_q = 65 \text{ kA at } 600 \text{ V} + 5 \%</math></b>					
<b>3RW4024</b>	12.5	3NA3 820-6	50	00	3RT2025/ 3RT2018 (in size S00)
<b>3RW4026</b>	25	3NA3822-6	63	00	3RT20 26
<b>3RW4027</b>	32	3NA3824-6	80	00	3RT20 27
<b>3RW4028</b>	38	3NA3824-6	80	00	3RT2028
<b>3RW4036</b>	45	3NA3130-6	100	1	3RT1036
<b>3RW4037</b>	63	3NA3132-6	125	1	3RT1044
<b>3RW4038</b>	72	3NA3132-6	125	1	3RT1045
<b>3RW4046</b>	80	3NA3136-6	160	1	3RT1045
<b>3RW4047</b>	106	3NA3136-6	160	1	3RT1046
<b>3RW4055</b>	134	3NA3244-6	250	2	3RT1055-6A.36
<b>3RW4056</b>	162	3NA3244-6	250	2	3RT1056-6A.36
<b>3RW4073</b>	230	2 x 3NA3354-6	2 x 355	3	3RT1065-6A.36
<b>3RW4074</b>	280	2 x 3NA3354-6	2 x 355	3	3RT1066-6A.36
<b>3RW4075</b>	356	2 x 3NA3365-6	2 x 500	3	3RT1075-6A.36
<b>3RW4076</b>	432	2 x 3NA3365-6	2 x 500	3	3RT1076-6A.36

<sup>1)</sup> The type of coordination "1" refers to soft starters in combination with the stipulated protective device (motor starter protector/fuse), not to any additional components in the feeder.

#### Fused version with 3NE1 SITOR fuses (semiconductor and line protection)

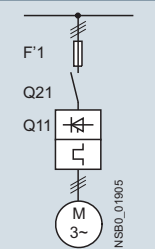

Matching fuse bases see  
[Catalog LV 10 → "Switch Disconnectors" and](#)  
[Catalog LV 10 → "Fuse Systems"](#)  
 → "SITOR Semiconductor Fuses"  
 or visit [www.siemens.com/sitor](http://www.siemens.com/sitor)

Soft starters	Nominal current	All-range fuses	Rated current	Size	Line contactors (optional)
Q11 Type	A	F1 Type	A		Q21 Type
<b>Type of coordination "2"<sup>1)</sup>: <math>I_q = 65 \text{ kA at } 600 \text{ V} + 5 \%</math></b>					
<b>3RW4024</b>	12.5	3NE1814-0	20	000	3RT2025/ 3RT2018 (in size S00)
<b>3RW4026</b>	25	3NE1803-0	35	000	3RT2026
<b>3RW4027</b>	32	3NE1020-2	80	00	3RT2027
<b>3RW4028</b>	38	3NE1020-2	80	00	3RT2028
<b>3RW4036</b>	45	3NE1020-2	80	00	3RT1036
<b>3RW4037</b>	63	3NE1820-0	80	000	3RT1044
<b>3RW4038</b>	72	3NE1820-0	80	000	3RT1045
<b>3RW4046</b>	80	3NE1021-0	100	00	3RT1045
<b>3RW4047</b>	106	3NE1022-0	125	00	3RT1046
<b>3RW4055</b>	134	3NE1227-2	250	1	3RT1055-6A.36
<b>3RW4056</b>	162	3NE1227-2	250	1	3RT1056-6A.36
<b>3RW4073</b>	230	3NE1331-2	350	2	3RT1065-6A.36
<b>3RW4074</b>	280	3NE1333-2	450	2	3RT1066-6A.36
<b>3RW4075</b>	356	3NE1334-2	500	2	3RT1075-6A.36
<b>3RW4076</b>	432	3NE1435-2	560	3	3RT1076-6A.36

<sup>1)</sup> The type of coordination "2" refers to soft starters in combination with the stipulated protective device (motor starter protector/fuse), not to any additional components in the feeder.



# SIRIUS 3RW Soft Starters

## 3RW30, 3RW40 for Standard Applications

3RW40

Fused version with 3NE3 SITOR fuses (semiconductor protection by fuse, line and overload protection by motor starter protector; alternatively, installation with contactor and overload relay possible)

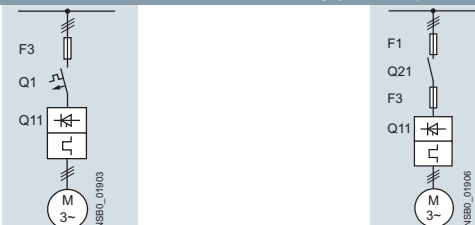

Matching fuse bases see  
 Catalog LV 10 → "Switch Disconnectors" and  
 Catalog LV 10 → "Fuse Systems"  
 → "SITOR Semiconductor Fuses"  
 or visit [www.siemens.com/sitor](http://www.siemens.com/sitor)

Soft starters Q11 Type	Nom. curr. A	Semiconductor fuses, minimum			Semiconductor fuses, maximum			Semiconductor fuses, minimum		
		F3 Type	Rated current A	Size	F3 Type	Rated current A	Size	F3 Type	Rated current A	Size
Type of coordination "2" <sup>1)</sup> : $I_q = 65 \text{ kA at } 600 \text{ V} + 5\%$ ( <sup>1)</sup> see previous page)										
3RW4024	12.5	--	--	--	--	--	--	3NE4101	32	0
3RW4026	25	--	--	--	3NE3221	100	1	3NE4102	40	0
3RW4027	32	--	--	--	3NE3224	160	1	3NE4118	63	0
3RW4028	38	--	--	--	3NE3224	160	1	3NE4118	63	0
3RW4036	45	--	--	--	3NE3224	160	1	3NE4120	80	0
3RW4037	63	--	--	--	3NE3225	200	1	3NE4121	100	0
3RW4038	72	3NE3221	100	1	3NE3227	250	1	--	--	--
3RW4046	80	3NE3222	125	1	3NE3225	200	1	--	--	--
3RW4047	106	3NE3224	160	1	3NE3231	350	1	--	--	--
3RW4055	134	3NE3227	250	1	3NE3335	560	2	--	--	--
3RW4056	162	3NE3227	250	1	3NE3335	560	2	--	--	--
3RW4073	230	3NE3232-0B	400	1	3NE3333	450	2	--	--	--
3RW4074	280	3NE3233	450	1	3NE3336	630	2	--	--	--
3RW4075	356	3NE3335	560	2	3NE3336	630	2	--	--	--
3RW4076	432	3NE3337-8	710	2	3NE3340-8	900	2	--	--	--

Soft starters Q11 Type	Nom. curr. A	Semiconductor fuses max.			Semiconductor fuses min.			Semiconductor fuses max.			Cylindrical fuses	
		F3 Type	Rated current A	Size	F3 Type	Rated current A	Size	F3 Type	Rated current A	Size	F3 Type	Rated current A
Type of coordination "2" <sup>1)</sup> : $I_q = 65 \text{ kA at } 600 \text{ V} + 5\%$ ( <sup>1)</sup> see previous page)												
3RW4024	12.5	3NE4117	50	0	3NE8015-1	25	00	3NE8017-1	50	00	3NC2240	40
3RW4026	25	3NE4117	50	0	3NE8017-1	50	00	3NE8021-1	100	00	3NC2263	63
3RW4027	32	3NE4118	63	0	3NE8018-1	63	00	3NE8022-1	125	00	3NC2280	80
3RW4028	38	3NE4118	63	0	3NE8020-1	80	00	3NE8024-1	160	00	3NC2280	80
3RW4036	45	3NE4120	80	0	3NE8020-1	80	00	3NE8024-1	160	00	3NC2280	80
3RW4037	63	3NE4121	100	0	3NE8021-1	100	00	3NE8024-1	160	00	--	--
3RW4038	72	--	--	--	3NE8022-1	125	00	3NE8024-1	160	00	--	--
3RW4046	80	--	--	--	3NE8022-1	125	00	3NE8024-1	160	00	--	--
3RW4047	106	--	--	--	3NE8024-1	160	00	3NE8024-1	160	00	--	--
3RW4055	134	--	--	--	--	--	--	--	--	--	--	--
3RW4056	162	--	--	--	--	--	--	--	--	--	--	--
3RW4073	230	--	--	--	--	--	--	--	--	--	--	--
3RW4074	280	--	--	--	--	--	--	--	--	--	--	--
3RW4075	356	--	--	--	--	--	--	--	--	--	--	--
3RW4076	432	--	--	--	--	--	--	--	--	--	--	--

Soft starters Q11 Type	Nom. curr. A	Line contactors (optional)		Motor starter protectors		Line protection, maximum			
		Q21 Type	Q1 Type	400 V + 10 % Rated current A	575 V + 10 % Rated current A	F1 Type	Rated current A	Size	
Type of coordination "2" <sup>1)</sup> : $I_q = 65 \text{ kA at } 600 \text{ V} + 5\%$ ( <sup>1)</sup> see previous page)									
3RW4024	12.5	3RT2025/ 3RT2018 (in size S00)	3RV2021-4AA/ 3RV2011-4AA (in size S00)	16	--	--	3NA3820-6	50	00
3RW4026	25	3RT2026	3RV2021-4DA	25	--	--	3NA3822-6	63	00
3RW4027	32	3RT2027	3RV2021-4EA	32	--	--	3NA3824-6	80	00
3RW4028	38	3RT2028	3RV2021-4FA	40	--	--	3NA3824-6	80	00
3RW4036	45	3RT1036	3RV1031-4GA10	45	--	--	3NA3130-6	100	1
3RW4037	63	3RT1044	3RV1041-4JA10	63	--	--	3NA3132-6	125	1
3RW4038	72	3RT1045	3RV1041-4KA10	75	--	--	3NA3132-6	125	1
3RW4046	80	3RT1045	3RV1041-4LA10	90	--	--	3NA3136-6	160	1
3RW4047	106	3RT1046	3RV1041-4MA10	100	--	--	3NA3136-6	160	1
3RW4055	134	3RT1055-6A.36	3VL3720	200	3VL3720	200	3NA3244-6	250	2
3RW4056	162	3RT1056-6A.36	3VL3720	200	3VL3720	200	3NA3244-6	250	2
3RW4073	230	3RT1065-6A.36	3VL4731	315	3VL5731	315	2 x 3NA3354-6	2 x 355	3
3RW4074	280	3RT1066-6A.36	3VL4731	315	3VL5731	315	2 x 3NA3354-6	2 x 355	3
3RW4075	356	3RT1075-6A.36	3VL4740	400	3VL5740	400	2 x 3NA3365-6	2 x 500	3
3RW4076	432	3RT1076-6A.36	3VL5750	500	3VL5750	500	2 x 3NA3365-6	2 x 500	3

# SIRIUS 3RW Soft Starters

## 3RW30, 3RW40 for Standard Applications

### 3RW40

#### Selection and ordering data

#### SIRIUS 3RW40 for normal starting (CLASS 10)



3RW ambient temperature 40 °C				3RW ambient temperature 50 °C				Size	DT <sup>1)</sup>	Normal starting (CLASS 10)	PU (UNIT, SET, M)	PS*	PG	
Rated values of three-phase motors				Rated values of three-phase motors										
Operational current I <sub>e</sub>	Rating at operational voltage U <sub>e</sub>			Operational current I <sub>e</sub>	Rating at operational voltage U <sub>e</sub>			A	A	Configurator	Article No.	Price per PU		
	230 V	400 V	500 V		200 V	230 V	460 V							575 V
A	kW	kW	kW	A	hp	hp	hp	hp	hp					
<b>Rated operational voltage U<sub>e</sub> 200 ... 480 V</b>														
12.5	3	5.5	--	11	3	3	7.5	--	S0	A	3RW4024-□BB□4	1	1 unit	42G
25	5.5	11	--	23	5	5	15	--	S0	A	3RW4026-□BB□4	1	1 unit	42G
32	7.5	15	--	29	7.5	7.5	20	--	S0	A	3RW4027-□BB□4	1	1 unit	42G
38	11	18.5	--	34	10	10	25	--	S0	A	3RW4028-□BB□4	1	1 unit	42G
45	11	22	--	42	10	15	30	--	S2	A	3RW4036-□BB□4	1	1 unit	42G
63	18.5	30	--	58	15	20	40	--	S2	A	3RW4037-□BB□4	1	1 unit	42G
72	22	37	--	62	20	20	40	--	S2	A	3RW4038-□BB□4	1	1 unit	42G
80	22	45	--	73	20	25	50	--	S3	A	3RW4046-□BB□4	1	1 unit	42G
106	30	55	--	98	30	30	75	--	S3	A	3RW4047-□BB□4	1	1 unit	42G
<b>Rated operational voltage U<sub>e</sub> 400 ... 600 V</b>														
12.5	--	5.5	7.5	11	--	--	7.5	10	S0	B	3RW4024-□BB□5	1	1 unit	42G
25	--	11	15	23	--	--	15	20	S0	B	3RW4026-□BB□5	1	1 unit	42G
32	--	15	18.5	29	--	--	20	25	S0	B	3RW4027-□BB□5	1	1 unit	42G
38	--	18.5	22	34	--	--	25	30	S0	B	3RW4028-□BB□5	1	1 unit	42G
45	--	22	30	42	--	--	30	40	S2	B	3RW4036-□BB□5	1	1 unit	42G
63	--	30	37	58	--	--	40	50	S2	B	3RW4037-□BB□5	1	1 unit	42G
72	--	37	45	62	--	--	40	60	S2	B	3RW4038-□BB□5	1	1 unit	42G
80	--	45	55	73	--	--	50	60	S3	B	3RW4046-□BB□5	1	1 unit	42G
106	--	55	75	98	--	--	75	75	S3	B	3RW4047-□BB□5	1	1 unit	42G

#### Article No. supplement for connection types

- With screw terminals
- With spring-type terminals<sup>2)</sup>

#### Article No. supplement for rated control supply voltage U<sub>c</sub>

- 24 V AC/DC
- 110 ... 230 V AC/DC

Online configurator see [www.siemens.com/sirius/configurators](http://www.siemens.com/sirius/configurators)

<sup>1)</sup> Soft starter U<sub>e</sub> 200 ... 480 V with screw terminals: delivery time class ► (preferred type).

<sup>2)</sup> Main circuit connection: screw terminals.

#### Note:

The listed motor ratings are rough guide values. The soft starter should always be designed on the basis of the required rated operational current of the motor.

The 3RW40 soft starters are designed for easy starting conditions. The selection and ordering data were determined for the following boundary conditions (see also the notes on page 6/6):

- Maximum starting time in s: 10
- Maximum starting current in % of motor current I<sub>e</sub>: 300
- Maximum number of starts per hour in 1/h: 5
- Stand-alone installation without auxiliary fan (Side-by-side see manual, <http://support.automation.siemens.com/WW/view/en/38752095>, Increase of switching frequency possible with an auxiliary fan)

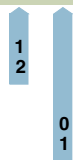

# SIRIUS 3RW Soft Starters

## 3RW30, 3RW40 for Standard Applications

3RW40



3RW402.



3RW403.



3RW404.

3RW ambient temperature 40 °C				3RW ambient temperature 50 °C				Size	DT <sup>1)</sup>	Normal starting (CLASS 10)	PU (UNIT, SET, M)	PS*	PG	
Rated values of three-phase motors				Rated values of three-phase motors										
Operational current $I_e$	Rating at operational voltage $U_e$			Operational current $I_e$	Rating at operational voltage $U_e$			Configurator	Article No.	Price per PU				
	230 V	400 V	500 V		200 V	230 V	460 V				575 V			
A	kW	kW	kW	A	hp	hp	hp	hp						
<b>Rated operational voltage <math>U_e</math> 200 ... 480 V, with thermistor motor protection, rated control supply voltage <math>U_s</math> 24 V AC/DC</b>														
12.5	3	<b>5.5</b>	--	11	3	3	<b>7.5</b>	--	<b>S0</b>	B	<b>3RW4024-□TB04</b>	1	1 unit	42G
25	5.5	<b>11</b>	--	23	5	5	<b>15</b>	--	<b>S0</b>	B	<b>3RW4026-□TB04</b>	1	1 unit	42G
32	7.5	<b>15</b>	--	29	7.5	7.5	<b>20</b>	--	<b>S0</b>	B	<b>3RW4027-□TB04</b>	1	1 unit	42G
38	11	<b>18.5</b>	--	34	10	10	<b>25</b>	--	<b>S0</b>	B	<b>3RW4028-□TB04</b>	1	1 unit	42G
45	11	<b>22</b>	--	42	10	15	<b>30</b>	--	<b>S2</b>	B	<b>3RW4036-□TB04</b>	1	1 unit	42G
63	18.5	<b>30</b>	--	58	15	20	<b>40</b>	--	<b>S2</b>	B	<b>3RW4037-□TB04</b>	1	1 unit	42G
72	22	<b>37</b>	--	62	20	20	<b>40</b>	--	<b>S2</b>	B	<b>3RW4038-□TB04</b>	1	1 unit	42G
80	22	<b>45</b>	--	73	20	25	<b>50</b>	--	<b>S3</b>	B	<b>3RW4046-□TB04</b>	1	1 unit	42G
106	30	<b>55</b>	--	98	30	30	<b>75</b>	--	<b>S3</b>	B	<b>3RW4047-□TB04</b>	1	1 unit	42G
<b>Rated operational voltage <math>U_e</math> 400 ... 600 V, with thermistor motor protection, rated control supply voltage <math>U_s</math> 24 V AC/DC</b>														
12.5	--	5.5	<b>7.5</b>	11	--	--	7.5	<b>10</b>	<b>S0</b>	B	<b>3RW4024-□TB05</b>	1	1 unit	42G
25	--	11	<b>15</b>	23	--	--	15	<b>20</b>	<b>S0</b>	B	<b>3RW4026-□TB05</b>	1	1 unit	42G
32	--	15	<b>18.5</b>	29	--	--	20	<b>25</b>	<b>S0</b>	B	<b>3RW4027-□TB05</b>	1	1 unit	42G
38	--	18.5	<b>22</b>	34	--	--	25	<b>30</b>	<b>S0</b>	B	<b>3RW4028-□TB05</b>	1	1 unit	42G
45	--	22	<b>30</b>	42	--	--	30	<b>40</b>	<b>S2</b>	B	<b>3RW4036-□TB05</b>	1	1 unit	42G
63	--	30	<b>37</b>	58	--	--	40	<b>50</b>	<b>S2</b>	B	<b>3RW4037-□TB05</b>	1	1 unit	42G
72	--	37	<b>45</b>	62	--	--	40	<b>60</b>	<b>S2</b>	B	<b>3RW4038-□TB05</b>	1	1 unit	42G
80	--	45	<b>55</b>	73	--	--	50	<b>60</b>	<b>S3</b>	B	<b>3RW4046-□TB05</b>	1	1 unit	42G
106	--	55	<b>75</b>	98	--	--	75	<b>75</b>	<b>S3</b>	B	<b>3RW4047-□TB05</b>	1	1 unit	42G

### Article No. supplement for connection types

- With screw terminals
- With spring-type terminals<sup>2)</sup>

Online configurator see [www.siemens.com/sirius/configurators](http://www.siemens.com/sirius/configurators)

<sup>1)</sup> Soft starter  $U_e$  200 ... 480 V with screw terminals: delivery time class ► (preferred type).

<sup>2)</sup> Main circuit connection: screw terminals.

### Note:

The listed motor ratings are rough guide values. The soft starter should always be designed on the basis of the required rated operational current of the motor.

The 3RW40 soft starters are designed for easy starting conditions. The selection and ordering data were determined for the following boundary conditions (see also the notes on page 6/6):

- Maximum starting time in s: 10
- Maximum starting current in % of motor current  $I_e$ : 300
- Maximum number of starts per hour in 1/h: 5
- Stand-alone installation without auxiliary fan (Side-by-side see manual, <http://support.automation.siemens.com/WW/view/en/38752095>, Increase of switching frequency possible with an auxiliary fan)

# SIRIUS 3RW Soft Starters

## 3RW30, 3RW40 for Standard Applications

### 3RW40



3RW405.



3RW407.

3RW ambient temperature 40 °C				3RW ambient temperature 50 °C				Size	DT <sup>1)</sup>	Normal starting (CLASS 10)	PU (UNIT, SET, M)	PS*	PG	
Rated values of three-phase motors				Rated values of three-phase motors										
Operational current $I_e$	Rating at operational voltage $U_e$			Operational current $I_e$	Rating at operational voltage $U_e$			Configurator	Article No.	Price per PU				
	230 V	400 V	500 V		200 V	230 V	460 V						575 V	
A	kW	kW	kW	A	hp	hp	hp	hp						
<b>Rated operational voltage <math>U_e</math> 200 ... 460 V</b>														
134	37	75	--	117	30	40	75	--	S6	B	3RW4055-□BB□4	1	1 unit	42G
162	45	90	--	145	40	50	100	--	B	B	3RW4056-□BB□4	1	1 unit	42G
230	75	132	--	205	60	75	150	--	S12	B	3RW4073-□BB□4	1	1 unit	42G
280	90	160	--	248	75	100	200	--	B	B	3RW4074-□BB□4	1	1 unit	42G
356	110	200	--	315	100	125	250	--	B	B	3RW4075-□BB□4	1	1 unit	42G
432	132	250	--	385	125	150	300	--	B	B	3RW4076-□BB□4	1	1 unit	42G
<b>Rated operational voltage <math>U_e</math> 400 ... 600 V</b>														
134	--	75	90	117	--	--	75	100	S6	B	3RW4055-□BB□5	1	1 unit	42G
162	--	90	110	145	--	--	100	150	B	B	3RW4056-□BB□5	1	1 unit	42G
230	--	132	160	205	--	--	150	200	S12	B	3RW4073-□BB□5	1	1 unit	42G
280	--	160	200	248	--	--	200	250	B	B	3RW4074-□BB□5	1	1 unit	42G
356	--	200	250	315	--	--	250	300	B	B	3RW4075-□BB□5	1	1 unit	42G
432	--	250	315	385	--	--	300	400	B	B	3RW4076-□BB□5	1	1 unit	42G

#### Article No. supplement for connection type<sup>2)</sup>

- With spring-type terminals
- With screw terminals

#### Article No. supplement for rated control supply voltage $U_s$ <sup>3)</sup>

- 115 V AC
- 230 V AC

Online configurator see [www.siemens.com/sirius/configurators](http://www.siemens.com/sirius/configurators)

1) Soft starter  $U_e$  200 ... 460 V with screw terminals: delivery time class ► (preferred type).  
Soft starter  $U_e$  400 ... 600 V with screw terminals: delivery time class A.

2) Main circuit connection: busbar connection.

3) Control by way of the internal 24 V DC supply and direct control via PLC possible.

#### Note:

The listed motor ratings are rough guide values. The soft starter should always be designed on the basis of the required rated operational current of the motor.

The 3RW40 soft starters are designed for easy starting conditions. The selection and ordering data were determined for the following boundary conditions (see also the notes on page 6/6):

- Maximum starting time in s: 10
- Maximum starting current in % of motor current  $I_e$ : 300
- Maximum number of starts per hour in 1/h: 5
- Stand-alone installation (side-by-side see manual, <http://support.automation.siemens.com/WW/view/en/38752095>)

In case of additional requirements, it may be necessary to choose a larger device. In some cases, however, the safety margins taken into account in the selection also permit the listed units to be used in boundary conditions which are slightly more demanding. Detailed technical information for a configuration which is tailored exactly to the application see manual.

# SIRIUS 3RW Soft Starters

## 3RW30, 3RW40 for Standard Applications

3RW40

### SIRIUS 3RW40 for heavy starting (CLASS 20)



3RW402.



3RW403.



3RW404.

3RW ambient temperature 40 °C				3RW ambient temperature 50 °C				Size	DT <sup>1)</sup>	Heavy starting (CLASS 20)	PU (UNIT, SET, M)	PS*	PG	
Rated values of three-phase motors				Rated values of three-phase motors										
Operational current $I_e$	Rating at operational voltage $U_e$			Operational current $I_e$	Rating at operational voltage $U_e$									
	230 V	400 V	500 V		200 V	230 V	460 V	575 V						
A	kW	kW	kW	A	hp	hp	hp	hp	Configurator	Article No.	Price per PU			
<b>Rated operational voltage <math>U_e</math> 200 ... 480 V</b>														
12.5	3	5.5	--	11	3	3	7.5	--	S0	A	3RW4026-□BB□4	1	1 unit	42G
25	5.5	11	--	23	5	5	15	--	S0	A	3RW4027-□BB□4	1	1 unit	42G
32	7.5	15	--	29	7.5	7.5	20	--	S2	A	3RW4036-□BB□4	1	1 unit	42G
38	11	18.5	--	34	10	10	25	--	S2	A	3RW4037-□BB□4	1	1 unit	42G
45	11	22	--	42	10	15	30	--	S2	A	3RW4037-□BB□4	1	1 unit	42G
63	18.5	30	--	58	15	20	40	--	S3	A	3RW4047-□BB□4	1	1 unit	42G
72	22	37	--	62	20	20	40	--	S3	A	3RW4047-□BB□4	1	1 unit	42G
<b>Rated operational voltage <math>U_e</math> 400 ... 600 V</b>														
12.5	--	5.5	7.5	11	--	--	7.5	10	S0	B	3RW4026-□BB□5	1	1 unit	42G
25	--	11	15	23	--	--	15	20	S0	B	3RW4027-□BB□5	1	1 unit	42G
32	--	15	18.5	29	--	--	20	25	S2	B	3RW4036-□BB□5	1	1 unit	42G
38	--	18.5	22	34	--	--	25	30	S2	B	3RW4037-□BB□5	1	1 unit	42G
45	--	22	30	42	--	--	30	40	S2	B	3RW4037-□BB□5	1	1 unit	42G
63	--	30	37	58	--	--	40	50	S3	B	3RW4047-□BB□5	1	1 unit	42G
72	--	37	45	62	--	--	40	60	S3	B	3RW4047-□BB□5	1	1 unit	42G

#### Article No. supplement for connection types

- With screw terminals
- With spring-type terminals<sup>2)</sup>

#### Article No. supplement for rated control supply voltage $U_s$

- 24 V AC/DC
- 110 ... 230 V AC/DC

Online configurator see [www.siemens.com/sirius/configurators](http://www.siemens.com/sirius/configurators)

<sup>1)</sup> Soft starter  $U_e$  200 ... 480 V with screw terminals: delivery time class ► (preferred type).

<sup>2)</sup> Main circuit connection: screw terminals.

#### Note:

The listed motor ratings are rough guide values. The soft starter should always be designed on the basis of the required rated operational current of the motor.

The 3RW40 soft starters are designed for easy starting conditions. The selection and ordering data were determined for the following boundary conditions (see also the notes on page 6/6):

- Maximum starting time in s: 20
- Maximum starting current in % of motor current  $I_e$ : 300
- Maximum number of starts per hour in 1/h: 5
- Stand-alone installation without auxiliary fan (Side-by-side see manual, <http://support.automation.siemens.com/WW/view/en/38752095>, Increase of switching frequency possible with an auxiliary fan)

In case of additional requirements, it may be necessary to choose a larger device. In some cases, however, the safety margins taken into account in the selection also permit the listed units to be used in boundary conditions which are slightly more demanding. Detailed technical information for a configuration which is tailored exactly to the application see manual.

# SIRIUS 3RW Soft Starters

## 3RW30, 3RW40 for Standard Applications

### 3RW40



3RW402.



3RW403.



3RW404.

3RW ambient temperature 40 °C				3RW ambient temperature 50 °C				Size	DT <sup>1)</sup>	Heavy starting (CLASS 20)	PU (UNIT, SET, M)	PS*	PG	
Rated values of three-phase motors				Rated values of three-phase motors										
Operational current $I_e$	Rating at operational voltage $U_e$			Operational current $I_e$	Rating at operational voltage $U_e$			Configurator	Article No.	Price per PU				
	230 V	400 V	500 V		200 V	230 V	460 V						575 V	
A	kW	kW	kW	A	hp	hp	hp	hp						
<b>Rated operational voltage <math>U_e</math> 200 ... 480 V, with thermistor motor protection, rated control supply voltage <math>U_s</math> 24 V AC/DC</b>														
12.5	3	<b>5.5</b>	--	11	3	3	<b>7.5</b>	--	<b>S0</b>	B	<b>3RW4026-□TB04</b>	1	1 unit	42G
25	5.5	<b>11</b>	--	23	5	5	<b>15</b>	--	<b>S0</b>	B	<b>3RW4027-□TB04</b>	1	1 unit	42G
32	7.5	<b>15</b>	--	29	7.5	7.5	<b>20</b>	--	<b>S2</b>	B	<b>3RW4036-□TB04</b>	1	1 unit	42G
38	11	<b>18.5</b>	--	34	10	10	<b>25</b>	--	<b>S2</b>	B	<b>3RW4037-□TB04</b>	1	1 unit	42G
45	11	<b>22</b>	--	42	10	15	<b>30</b>	--	<b>S2</b>	B	<b>3RW4037-□TB04</b>	1	1 unit	42G
63	18.5	<b>30</b>	--	58	15	20	<b>40</b>	--	<b>S3</b>	B	<b>3RW4047-□TB04</b>	1	1 unit	42G
72	22	<b>37</b>	--	62	20	20	<b>40</b>	--	<b>S3</b>	B	<b>3RW4047-□TB04</b>	1	1 unit	42G
<b>Rated operational voltage <math>U_e</math> 400 ... 600 V, with thermistor motor protection, rated control supply voltage <math>U_s</math> 24 V AC/DC</b>														
12.5	--	5.5	<b>7.5</b>	11	--	--	7.5	<b>10</b>	<b>S0</b>	B	<b>3RW4026-□TB05</b>	1	1 unit	42G
25	--	11	<b>15</b>	23	--	--	15	<b>20</b>	<b>S0</b>	B	<b>3RW4027-□TB05</b>	1	1 unit	42G
32	--	15	<b>18.5</b>	29	--	--	20	<b>25</b>	<b>S2</b>	B	<b>3RW4036-□TB05</b>	1	1 unit	42G
38	--	18.5	<b>22</b>	34	--	--	25	<b>30</b>	<b>S2</b>	B	<b>3RW4037-□TB05</b>	1	1 unit	42G
45	--	22	<b>30</b>	42	--	--	30	<b>40</b>	<b>S2</b>	B	<b>3RW4037-□TB05</b>	1	1 unit	42G
63	--	30	<b>37</b>	58	--	--	40	<b>50</b>	<b>S3</b>	B	<b>3RW4047-□TB05</b>	1	1 unit	42G
72	--	37	<b>45</b>	62	--	--	40	<b>60</b>	<b>S3</b>	B	<b>3RW4047-□TB05</b>	1	1 unit	42G

#### Article No. supplement for connection types

- With screw terminals
- With spring-type terminals<sup>2)</sup>

Online configurator see [www.siemens.com/sirius/configurators](http://www.siemens.com/sirius/configurators)

<sup>1)</sup> Soft starter  $U_e$  200 ... 480 V with screw terminals: delivery time class ► (preferred type).

<sup>2)</sup> Main circuit connection: screw terminals.

#### Note:

The listed motor ratings are rough guide values. The soft starter should always be designed on the basis of the required rated operational current of the motor.

The 3RW40 soft starters are designed for easy starting conditions. The selection and ordering data were determined for the following boundary conditions (see also the notes on page 6/6):

- Maximum starting time in s: 20
- Maximum starting current in % of motor current  $I_e$ : 300
- Maximum number of starts per hour in 1/h: 5
- Stand-alone installation without auxiliary fan (Side-by-side see manual, <http://support.automation.siemens.com/WW/view/en/38752095>, Increase of switching frequency possible with an auxiliary fan)

In case of additional requirements, it may be necessary to choose a larger device. In some cases, however, the safety margins taken into account in the selection also permit the listed units to be used in boundary conditions which are slightly more demanding. Detailed technical information for a configuration which is tailored exactly to the application see manual.

# SIRIUS 3RW Soft Starters

## 3RW30, 3RW40 for Standard Applications

3RW40



3RW405.



3RW407.

3RW ambient temperature 40 °C				3RW ambient temperature 50 °C				Size	DT <sup>1)</sup>	Heavy starting (CLASS 20)	PU (UNIT, SET, M)	PS*	PG	
Rated values of three-phase motors				Rated values of three-phase motors										
Operational current $I_e$	Rating at operational voltage $U_e$			Operational current $I_e$	Rating at operational voltage $U_e$			Configurator	Article No.	Price per PU				
	230 V	400 V	500 V		200 V	230 V	460 V							575 V
A	kW	kW	kW	A	hp	hp	hp	hp						
<b>Rated operational voltage <math>U_e</math> 200 ... 460 V</b>														
80	22	<b>45</b>	--	73	20	25	<b>50</b>	--	<b>S6</b>	B	<b>3RW4055-□BB□4</b>	1	1 unit	42G
106	30	<b>55</b>	--	98	25	30	<b>60</b>	--	<b>S6</b>	B	<b>3RW4055-□BB□4</b>	1	1 unit	42G
134	37	<b>75</b>	--	117	30	40	<b>75</b>	--	<b>S6</b>	B	<b>3RW4056-□BB□4</b>	1	1 unit	42G
162	45	<b>90</b>	--	145	40	50	<b>100</b>	--	<b>S12</b>	B	<b>3RW4073-□BB□4</b>	1	1 unit	42G
230	75	<b>132</b>	--	205	60	75	<b>150</b>	--	<b>S12</b>	B	<b>3RW4074-□BB□4</b>	1	1 unit	42G
280	90	<b>160</b>	--	248	75	100	<b>200</b>	--	<b>S12</b>	B	<b>3RW4075-□BB□4</b>	1	1 unit	42G
356	110	<b>200</b>	--	315	100	125	<b>250</b>	--	<b>S12</b>	B	<b>3RW4076-□BB□4</b>	1	1 unit	42G
<b>Rated operational voltage <math>U_e</math> 400 ... 600 V</b>														
80	--	45	<b>55</b>	73	--	--	50	<b>60</b>	<b>S6</b>	B	<b>3RW4055-□BB□5</b>	1	1 unit	42G
106	--	55	<b>75</b>	98	--	--	60	<b>75</b>	<b>S6</b>	B	<b>3RW4055-□BB□5</b>	1	1 unit	42G
134	--	75	<b>90</b>	117	--	--	75	<b>100</b>	<b>S6</b>	B	<b>3RW4056-□BB□5</b>	1	1 unit	42G
162	--	90	<b>110</b>	145	--	--	100	<b>150</b>	<b>S12</b>	B	<b>3RW4073-□BB□5</b>	1	1 unit	42G
230	--	132	<b>160</b>	205	--	--	150	<b>200</b>	<b>S12</b>	B	<b>3RW4074-□BB□5</b>	1	1 unit	42G
280	--	160	<b>200</b>	248	--	--	200	<b>250</b>	<b>S12</b>	B	<b>3RW4075-□BB□5</b>	1	1 unit	42G
356	--	200	<b>250</b>	315	--	--	250	<b>300</b>	<b>S12</b>	B	<b>3RW4076-□BB□5</b>	1	1 unit	42G

### Article No. supplement for connection type<sup>2)</sup>

- With spring-type terminals
- With screw terminals

### Article No. supplement for rated control supply voltage $U_s$ <sup>3)</sup>

- 115 V AC
- 230 V AC

Online configurator see [www.siemens.com/sirius/configurators](http://www.siemens.com/sirius/configurators)

- Soft starter  $U_e$  200 ... 460 V with screw terminals: delivery time class ► (preferred type).  
Soft starter  $U_e$  400 ... 600 V with screw terminals: delivery time class A.
- Main circuit connection: busbar connection.
- Control by way of the internal 24 V DC supply and direct control via PLC possible.

### Note:

The listed motor ratings are rough guide values. The soft starter should always be designed on the basis of the required rated operational current of the motor.

The 3RW40 soft starters are designed for easy starting conditions. The selection and ordering data were determined for the following boundary conditions (see also the notes on page 6/6):

- Maximum starting time in s: 40
- Maximum starting current in % of motor current  $I_e$ : 350
- Maximum number of starts per hour in 1/h: 1
- Stand-alone installation (side-by-side see manual, <http://support.automation.siemens.com/WW/view/en/38752095>)

In case of additional requirements, it may be necessary to choose a larger device. In some cases, however, the safety margins taken into account in the selection also permit the listed units to be used in boundary conditions which are slightly more demanding. Detailed technical information for a configuration which is tailored exactly to the application see manual.

# SIRIUS 3RW Soft Starters

## 3RW30, 3RW40 for Standard Applications

3RW40

### Accessories

Conductor cross-section			Tightening torque	For soft starters size	DT	Article No.	Price per PU	PU (UNIT, SET, M)	PS*	PG
Solid or stranded	Finely stranded with end sleeve	AWG cables, solid or stranded								
mm <sup>2</sup>	mm <sup>2</sup>	AWG	Nm							

#### Three-phase infeed terminals



3RV2925-5AB

2.5 ... 25	2.5 ... 16	10 ... 4	3 ... 4	S0 (3RW402.)	▶	<b>3RV2925-5AB</b>		1	1 unit	41E
------------	------------	----------	---------	--------------	---	--------------------	--	---	--------	-----

For soft starters		Version	DT	Article No.	Price per PU	PU (UNIT, SET, M)	PS*	PG
Type	Size							

#### Box terminal blocks for soft starters



For round and ribbon cables (2 units required for each device)		DT	Article No.	Price per PU	PU (UNIT, SET, M)	PS*	PG
3RW405.	S6						
	• Up to 70 mm <sup>2</sup>	▶	<b>3RT1955-4G</b>		1	1 unit	41B
	• Up to 120 mm <sup>2</sup>	▶	<b>3RT1956-4G</b>		1	1 unit	41B
	<b>Auxiliary conductor connection for box terminals</b>	B	<b>3TX7500-0A</b>		1	1 unit	41B
3RW407.	S12	▶	<b>3RT1966-4G</b>		1	1 unit	41B

#### Auxiliary terminals

Auxiliary terminals, 3-pole		DT	Article No.	Price per PU	PU (UNIT, SET, M)	PS*	PG
3RW404.	S3						
		B	<b>3RT1946-4F</b>		1	1 unit	41B

#### Covers for soft starters



Terminal covers for box terminals Additional touch protection to be fitted at the box terminals (2 units required per device)		DT	Article No.	Price per PU	PU (UNIT, SET, M)	PS*	PG
3RW403.	S2						
3RW404.	S3	▶	<b>3RT1946-4EA2</b>		1	1 unit	41B
3RW405.	S6	▶	<b>3RT1956-4EA2</b>		1	1 unit	41B
3RW407.	S12	▶	<b>3RT1966-4EA2</b>		1	1 unit	41B



Terminal cover for cable lugs and busbar connections		DT	Article No.	Price per PU	PU (UNIT, SET, M)	PS*	PG
3RW404.	S3						
3RW405.	S6	▶	<b>3RT1956-4EA1</b>		1	1 unit	41B
3RW407.	S12	▶	<b>3RT1966-4EA1</b>		1	1 unit	41B

Also fits in case of S6 and S12 on mounted box terminals



Sealing covers		DT	Article No.	Price per PU	PU (UNIT, SET, M)	PS*	PG
3RW402. to 3RW404.	S0, S2, S3						
3RW405. and 3RW407.	S6, S12	▶	<b>3RW4900-0PB00</b>		1	1 unit	42G



# SIRIUS 3RW Soft Starters

## 3RW30, 3RW40 for Standard Applications

3RW40

For soft starters Type	Version Size	DT	Article No.	Price per PU	PU (UNIT, SET, M)	PS*	PG
---------------------------	-----------------	----	-------------	-----------------	-------------------------	-----	----

### Modules for RESET<sup>1)</sup>



#### Modules for remote RESET, electrical

Operating range 0.85 ... 1.1 x  $U_s$ ,  
power consumption AC 80 VA, DC 70 W,  
ON period 0.2 ... 4 s,  
switching frequency 60/h

3RW405. and 3RW407.	<b>S6,</b> <b>S12</b>	• 24 ... 30 V AC/DC • 110 ... 127 V AC/DC • 220 ... 250 V AC/DC	A A A	<b>3RU1900-2AB71</b> <b>3RU1900-2AF71</b> <b>3RU1900-2AM71</b>	1 1 1	1 unit 1 unit 1 unit	41F 41F 41F
------------------------	--------------------------	---	-------------	--	-------------	----------------------------	-------------------



#### Mechanical RESET comprising

3RW405. and 3RW407.	<b>S6,</b> <b>S12</b>	• Resetting plungers, holders and formers	▶	<b>3RU1900-1A</b>	1	1 unit	41F
		• Matching pushbutton IP65, Ø 22 mm, 12 mm stroke	B	<b>3SB3000-0EA11</b>	1	1 unit	41J
		• Extension plungers	A	<b>3SX1335</b>	1	1 unit	41J



#### Cable releases with holder for RESET

For Ø 6.5 mm holes in the control panel;  
max. control panel thickness 8 mm

3RW405. and 3RW407.	<b>S6,</b> <b>S12</b>	• Length 400 mm • Length 600 mm	▶ ▶	<b>3RU1900-1B</b> <b>3RU1900-1C</b>	1 1	1 unit 1 unit	41F 41F
------------------------	--------------------------	------------------------------------	--------	--	--------	------------------	------------

<sup>1)</sup> Remote RESET already integrated in the 3RW402. to 3RW404. soft starters.

For soft starters Type	Version Size	DT	Article No.	Price per PU	PU (UNIT, SET, M)	PS*	PG
---------------------------	-----------------	----	-------------	-----------------	-------------------------	-----	----

### Fans (to increase switching frequency and for device mounting in positions other than the standard position)



3RW402.	<b>S0</b>	▶	<b>3RW4928-8VB00</b>	1	1 unit	42G
3RW403., 3RW404.	<b>S2,</b> <b>S3</b>	▶	<b>3RW4947-8VB00</b>	1	1 unit	42G

### Manual 3RW30/3RW40<sup>1)</sup>

<sup>1)</sup> The relevant operating instructions for 3RW402./3./4. (3ZX1012-0RW40-2DA1) or 3RW405./7. (3ZX1012-0RW40-1AA1) are included in the scope of supply of the soft starter or are available – like the Manual – for download from the Service&Support portal in PDF format:  
[www.siemens.com/industrial-controls/support](http://www.siemens.com/industrial-controls/support) → "Switching Devices" → "Soft Starters and Solid-State Switching Devices" → "SIRIUS 3RW Soft Starters".

# SIRIUS 3RW Soft Starters

## 3RW30, 3RW40 for Standard Applications

### 3RW40

For soft starters Type	Size	Motor starter protector Size	DT	Article No.	Price per PU	PU (UNIT, SET, M)	PS*	PG
---------------------------	------	---------------------------------	----	-------------	-----------------	-------------------------	-----	----

#### Link modules to motor starter protectors<sup>1)</sup>

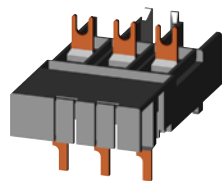

3RA2921-1BA00

- With screw terminals

3RW402.	<b>S0</b>	<b>S00/S0</b>	A	<b>3RA2921-1BA00</b>		1	1 unit	41B
3RW4036.	<b>S2</b>	<b>S2</b>	▶	<b>3RA1931-1AA00</b>		1	1 unit	41B
3RW4046., 3RW4047.	<b>S3</b>	<b>S3</b>	▶	<b>3RA1941-1AA00</b>		1	1 unit	41B

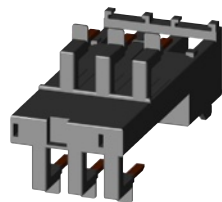

3RA2921-2GA00

- With spring-type terminals

3RW402.	<b>S0</b>	<b>S0</b>	▶	<b>3RA2921-2GA00</b>		1	1 unit	41B
---------	-----------	-----------	---	----------------------	--	---	--------	-----

- <sup>1)</sup> Can be used in size S0 up to maximum 32 A.  
Can be used in size S0 only for 3RV2 motor starter protectors.

Version	DT	Article No.	Price per PU	PU (UNIT, SET, M)	PS*	PG
---------	----	-------------	-----------------	----------------------	-----	----

#### Tool for opening spring-type terminals in sizes S00 and S0



3RA2908-1A

#### Screwdrivers

For all SIRIUS devices with spring-type terminals  
length approx. 200 mm, 3.0 mm x 0.5 mm,  
titanium gray/black, partially insulated

#### Spring-type terminals

**3RA29 08-1A**

1 1 unit 41B

#### Blank labels

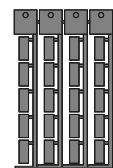

3RT2900-1SB20

#### Unit labeling plates<sup>1)</sup>

For SIRIUS devices

- 20 mm x 7 mm, titanium gray

D **3RT2900-1SB20** 100 340 units 41B

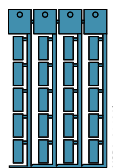

3RT1900-1SB20

- 20 mm x 7 mm, pastel turquoise

D **3RT1900-1SB20** 100 340 units 41B

- <sup>1)</sup> PC labeling systems for individual inscription  
of unit labeling plates are available from:  
murrplastik Systemtechnik GmbH  
(see Chapter 16, "Appendix" → "External Partners").

#### Spare parts

For soft starters Type	Size	Version Rated control supply voltage $U_s$	DT	Article No.	Price per PU	PU (UNIT, SET, M)	PS*	PG
---------------------------	------	--	----	-------------	-----------------	-------------------------	-----	----

#### Fans



#### Fans

3RW405.-.BB3.	<b>S6</b>	115 V AC	▶	<b>3RW4936-8VX30</b>		1	1 unit	42G
3RW405.-.BB4.	<b>S6</b>	230 V AC	▶	<b>3RW4936-8VX40</b>		1	1 unit	42G
3RW407.-.BB3.	<b>S12</b>	115 V AC	▶	<b>3RW4947-8VX30</b>		1	1 unit	42G
3RW407.-.BB4.	<b>S12</b>	230 V AC	▶	<b>3RW4947-8VX40</b>		1	1 unit	42G

# SIRIUS 3RW Soft Starters

## 3RW30, 3RW40 for Standard Applications

3RW40

### More information

#### Application examples for normal starting (CLASS 10)

**Normal starting CLASS 10** (up to 20 s with 350%  $I_{n \text{ motor}}$ , one start per hour)  
The soft starter rating can be selected to be as high as the rating of the motor used.

Application		Conveyor belts	Roller conveyors	Compressors	Small fans <sup>1)</sup>	Pumps	Hydraulic pumps
<b>Starting parameters</b>							
• Voltage ramp and current limiting							
- Starting voltage	%	70	60	50	40	40	40
- Starting time	s	10	10	10	10	10	10
- Current limit value		$5 \times I_M$	$5 \times I_M$	$4 \times I_M$	$4 \times I_M$	$4 \times I_M$	$4 \times I_M$
<b>Ramp-down time</b>	s	5	5	0	0	10	0

<sup>1)</sup> The mass inertia of the fan is <10 times the mass inertia of the motor.

#### Application examples for heavy starting (CLASS 20)

**Heavy starting CLASS 20** (up to 40 s with 350%  $I_{n \text{ motor}}$ , one start per hour)  
The soft starter has to be selected at least one performance class higher than the motor used.

Application		Stirrers	Centrifuges
<b>Starting parameters</b>			
• Voltage ramp and current limiting			
- Starting voltage	%	40	40
- Starting time	s	20	20
- Current limit value		$4 \times I_M$	$4 \times I_M$
<b>Stopping time</b>		0	0

#### Note:

These tables present sample set values and device dimensions. They are intended only for the purposes of information and are not binding. The set values depend on the application in question and must be optimized during commissioning.

The soft starter dimensions should be checked where necessary with the help of Technical Assistance.

# SIRIUS 3RW Soft Starters

## 3RW30, 3RW40 for Standard Applications

### 3RW40

#### Configuration

The 3RW solid-state soft starters are designed for easy starting conditions. In the event of deviating conditions or increased switching frequency, it may be necessary to choose a larger device.

Where long starting times are involved, the integrated solid-state overload relay for heavy starting should not be disconnected. PTC sensors are recommended. This also applies for the soft ramp-down because during the ramp-down time an additional current loading applies in contrast to free ramp-down.

In the case of high switching frequencies in S4 mode, Siemens recommends the use of PTC sensors. For relevant device versions with integrated thermistor motor protection or separate thermistor evaluation devices, see Chapter 10 "Monitoring and Control Devices".

No capacitive elements are permitted in the motor feeder between the SIRIUS 3RW soft starter and the motor (e.g. no reactive-power compensation equipment). In addition, neither static systems for reactive-power compensation nor dynamic PFC (Power Factor Correction) must be operated in parallel during starting and ramp-down of the soft starter. This is important to prevent faults arising on the compensation equipment and/or the soft starter.

All elements of the main circuit (such as fuses and controls) should be dimensioned for direct starting, following the local short-circuit conditions. Fuses, controls and overload relays must be ordered separately. Please observe the maximum switching frequencies specified in the technical specifications.

#### Note:

When three-phase motors are switched on, voltage drops occur as a rule on starters of all types (direct-on-line starters, wye-delta starters, soft starters). The infeed transformer must always be dimensioned such that the voltage dip when starting the motor remains within the permissible tolerance. If the infeed transformer is dimensioned with only a small margin, it is best for the control voltage to be supplied from a separate circuit (independently of the main voltage) in order to avoid the potential switching off of the soft starter.

#### Schematic circuit diagram of power electronics

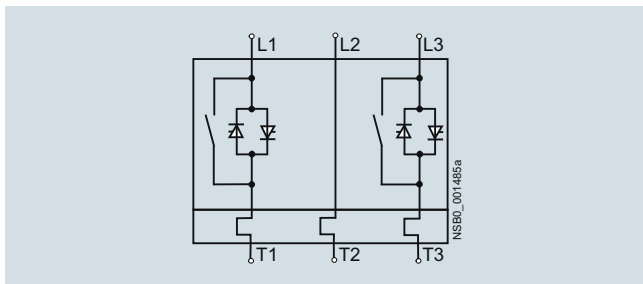

A bypass contact system and solid-state overload relay are already integrated in the 3RW40 soft starter and therefore do not have to be ordered separately.

#### Status graphs

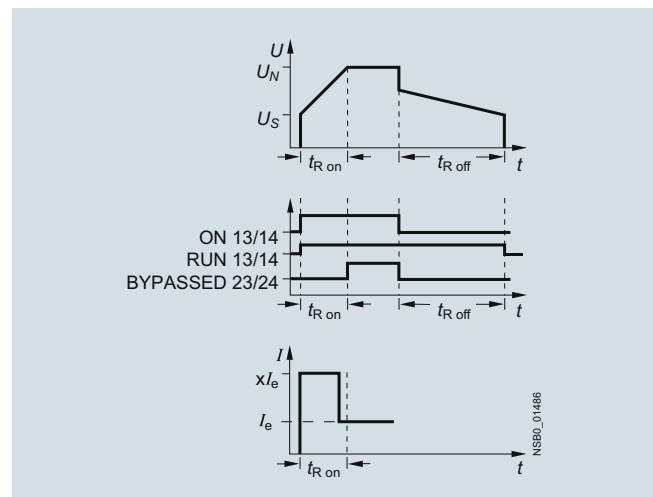

#### Manual for SIRIUS 3RW30/40

Besides containing all important information on configuring, commissioning and servicing, the manual also contains example circuits and the technical specifications for all devices.  
<http://support.automation.siemens.com/WW/view/en/38752095>

# SIRIUS 3RW Soft Starters

## 3RW44 for High-Feature Applications

3RW44

### Overview



3RW44 soft starter with PROFINET communication module

In addition to soft starting and soft ramp-down, the solid-state SIRIUS 3RW44 soft starters provide numerous functions for higher-level requirements. They cover a performance range up to 710 kW (at 400 V) in the inline circuit and up to 1200 kW (at 400 V) in the inside-delta circuit.

The 3RW44 soft starters are characterized by a compact design for space-saving and clearly arranged control cabinet layouts. For optimized motor starting and stopping the innovative SIRIUS 3RW44 soft starters are an attractive alternative with considerable savings potential compared to applications with a frequency converter. The new torque control and adjustable current limiting enable the High-Feature soft starters to be used in nearly every conceivable task. They guarantee the reliable avoidance of sudden torque applications and current peaks during motor starting and stopping. This creates savings potential when calculating the size of the switchgear and when servicing the machinery installed. Be it for inline circuits or inside-delta circuits – the SIRIUS 3RW44 soft starter offers savings especially in terms of size and equipment costs.

The bypass contacts already integrated in the soft starter bypass the thyristors after a motor ramp-up is detected. This results in a further great reduction in the heat loss occurring during operation of the soft starter at rated value.

Combinations of various starting, operating and ramp-down possibilities ensure an optimum adaptation to the application-specific requirements. Operation and commissioning can be performed with the menu-controlled keypad and a menu-prompted, multi-line graphic display with background lighting. The optimized motor ramp-up and ramp-down can be effected quickly, easily and reliably by means of just a few settings with a previously selected language. Four-key operation and plain-text displays for each menu point guarantee full clarity at every moment of the parameterization and operation.

#### Applicable standards

- IEC 60947-4-2
- UL/CSA

#### Functionality

Equipped with modern, ergonomic user prompting the 3RW44 soft starters can be commissioned quickly and easily using a keypad and a menu-prompted, multi-line graphic display with background lighting. The optimized motor ramp-up and ramp-down can be effected quickly, easily and reliably by means of just a few settings with a selectable language. Four-key operation and plain-text displays for each menu point guarantee full clarity at every moment of the parameterization and operation. During operation and when control voltage is applied, the display field continuously presents measured values and operating values as well as warnings and fault messages. An external dis-

play and operator module can be connected by means of a connection cable to the soft starter, thus enabling active indications and the like to be read directly from the control cabinet door.

The SIRIUS 3RW44 soft starters are equipped with optimum functionality. An integral bypass contact system reduces the power loss of the soft starter during operation. This reliably prevents heating of the switchgear environment. The SIRIUS 3RW44 soft starters have internal intrinsic device protection. This prevents thermal overloading of the power section's thyristors, e.g. due to unacceptably high closing operations.

Wiring outlay for installing an additional motor overload relay is no longer needed as the SIRIUS 3RW44 soft starters perform this function too. In addition they offer adjustable trip classes and a thermistor motor protection function. As an option the thyristors can also be protected by SITOP semiconductor fuses from short-circuiting so that the soft starter is still functional after a short circuit (type of coordination "2"). And even inrush current peaks are reliably avoided thanks to adjustable current limiting.

Optionally, SIRIUS 3RW44 soft starters can be upgraded with a PROFIBUS DP or PROFINET module. Thanks to their communication capability and their programmable control inputs and relay outputs the SIRIUS 3RW44 soft starters can be very easily and quickly integrated in higher-level controllers.

In addition a creep speed function is available for positioning and setting jobs. With this function the motor can be controlled in both directions of rotation with reduced torque and an adjustable, low speed.

On the other hand the SIRIUS 3RW44 soft starters offer a new, combined DC braking function for the fast stopping of driving loads.

#### Highlights

- Soft starting with breakaway pulse, torque control or voltage ramp, adjustable torque or current limiting as well as any combination of these, depending on load type
- Integrated bypass contact system to minimize power loss
- Various setting options for the starting parameters such as starting torque, starting voltage, ramp-up and ramp-down time, and much more in three separate parameter sets
- Start-up detection
- Inside-delta circuit for savings in terms of size and equipment costs
- Various ramp-down modes selectable: free ramp-down, torque-controlled pump ramp-down, combined DC braking
- Solid-state motor overload and intrinsic device protection
- Thermistor motor protection
- Keypad with a menu-prompted, multi-line graphic display with background lighting
- Interface for communication with the PC for more accurate setting of the parameters as well as for control and monitoring
- Simple integration to the motor feeder
- Simple mounting and commissioning
- Display of operating states and fault messages
- Connection to PROFIBUS and PROFINET with optional PROFIBUS DP or PROFINET module
- External display and operator module
- Mains voltages from 200 to 690 V, 50 to 60 Hz
- Can be used up to 60 °C (derating from 40 °C)

6

# SIRIUS 3RW Soft Starters

## 3RW44 for High-Feature Applications

### 3RW44

#### Soft Starter ES parameterization software<sup>1)</sup>

Soft Starter ES software is used for the parameterization, monitoring and service diagnostics of SIRIUS 3RW44 High-Feature soft starters.

#### SIRIUS 3RW44 Soft Starter block library for SIMATIC PCS 7<sup>1)</sup>

The SIRIUS 3RW44 Soft Starter PCS 7 block library can be used for simple and easy integration of SIRIUS 3RW44 soft starters into the SIMATIC PCS 7 process control system.

<sup>1)</sup> See Chapter 14 "Parameterization, Configuration and Visualization with SIRIUS".

#### Application

The solid-state SIRIUS 3RW44 soft starters are suitable for the torque-controlled soft starting and ramp-down as well as braking of three-phase asynchronous motors.

#### Application areas

See "Selection aid for soft starters" on page 6/6.

#### Technical specifications

Type		3RW442.	3RW443.	3RW444.	3RW445.	3RW446.
<b>Mechanics and environment</b>						
<b>Mounting dimensions (WxHxD)</b>						
• Screw terminals		170 x 184 x 270	170 x 198 x 270	210 x 230 x 298	510 x 638.5 x 290	576 x 667 x 290
• Spring-type terminals		170 x 184 x 270	170 x 198 x 270	210 x 230 x 298	510 x 638.5 x 290	576 x 667 x 290
<b>Permissible ambient temperature</b>						
Operation	°C	0 ... +60; (derating from +40)				
Storage	°C	-25 ... +80				
<b>Weight</b>	kg	6.5	7.9	11.5	50	78
<b>Permissible mounting position</b>						
<b>Installation type</b>						
Stand-alone installation						
<b>Permissible installation altitude</b>						
m		5000 (derating from 1000, see <a href="#">Characteristic Curves page 6/7</a> ); higher on request				
<b>Degree of protection</b>						
		IP00				

Type	Terminal		3RW44...BC3.	3RW44...BC4.
<b>Control electronics</b>				
<b>Rated values</b>				
Rated control supply voltage	A1/A2/PE	V	115 AC	230 AC
• Tolerance		%	-15/+10	-15/+10
Rated frequency		Hz	50 ... 60	50 ... 60
• Tolerance		%	±10	±10

Type		3RW44...BC.4	3RW44...BC.5	3RW44...BC.6
<b>Power electronics</b>				
<b>Rated operational voltage for inline circuit</b>				
Rated operational voltage	V AC	200 ... 460	400 ... 600	400 ... 690
Tolerance	%	-15/+10	-15/+10	-15/+10
<b>Maximum blocking voltage (thyristor)</b>				
Maximum blocking voltage	V AC	1 400	1 800	1 800
<b>Rated operational voltage for inside-delta circuit</b>				
Rated operational voltage	V AC	200 ... 460	400 ... 600	400 ... 600
Tolerance	%	-15/+10	-15/+10	-15/+10
<b>Rated frequency</b>				
Rated frequency	Hz	50 ... 60		
Tolerance	%	±10		
<b>Uninterrupted duty at 40 °C (% of I<sub>e</sub>)</b>				
Uninterrupted duty	%	115		
<b>Minimum load (% of set motor current I<sub>M</sub>)</b>				
Minimum load	%	8		
<b>Maximum cable length between soft starter and motor</b>				
Maximum cable length	m	500 <sup>1)</sup>		

<sup>1)</sup> At the project configuration stage, it is important to make allowance for the voltage drop on the motor cable up to the motor connection. If necessary, higher values for the rated operational voltage or current must be calculated accordingly for the soft starter.

# SIRIUS 3RW Soft Starters

## 3RW44 for High-Feature Applications

3RW44

Type		3RW4422	3RW4423	3RW4424	3RW4425	3RW4426	3RW4427
<b>Power electronics</b>							
<b>Rated operational current <math>I_e</math></b>		29	36	47	57	77	93
<b>Load rating with rated operational current <math>I_e</math></b>							
• According to IEC and UL/CSA <sup>1)</sup> , for individual mounting, AC-53a - At 40 / 50 / 60 °C	A	29 / 26 / 23	36 / 32 / 29	47 / 42 / 37	57 / 51 / 45	77 / 68 / 59	93 / 82 / 72
<b>Smallest adjustable rated motor current <math>I_M</math></b>	A	5	7	9	11	15	18
For the motor overload protection							
<b>Power loss</b>							
• In operation after completed starting with uninterrupted rated operational current (40 / 50 / 60°C) approx.	W	8 / 7.5 / 7	10 / 9 / 8.5	32 / 31 / 29	36 / 34 / 31	45 / 41 / 37	55 / 51 / 47
• During starting with current limit set to 350 % $I_M$ (40 / 50 / 60 °C)	W	400/345/290	470/410/355	600/515/440	725/630/525	940/790/660	1160/980/830
<b>Permissible rated motor current and starts per hour at 40 °C / 50 °C / 60 °C</b>							
<b>• For normal starting (CLASS 5)</b>							
- Rated motor current $I_M^{(2)}$ , starting time 5 s	A	29 / 26 / 23	36 / 32.5 / 29	47 / 42 / 37	57 / 51 / 45	77 / 68 / 59	93 / 82 / 72
- Starts per hour <sup>3)</sup>	1/h	41	34	41	41	41	41
- Rated motor current $I_M^{(2)}$ , starting time 10 s	A	29 / 26 / 23	36 / 32.5 / 29	47 / 42 / 37	57 / 51 / 45	77 / 68 / 59	93 / 82 / 72
- Starts per hour <sup>3)</sup>	1/h	20	15	20	20	20	20
<b>• For normal starting (CLASS 10)</b>							
- Rated motor current $I_M^{(2)}$ , starting time 10 s	A	29 / 26 / 23	36 / 32.5 / 29	47 / 42 / 37	57 / 51 / 45	77 / 68 / 59	93 / 82 / 72
- Starts per hour <sup>3)</sup>	1/h	20	15	20	20	20	20
- Rated motor current $I_M^{(2)}$ , starting time 20 s	A	29 / 26 / 23	36 / 32.5 / 29	47 / 42 / 37	57 / 51 / 45	77 / 68 / 59	93 / 82 / 72
- Starts per hour <sup>3)</sup>	1/h	10	6	10	10	8	8
<b>• For normal starting (CLASS 15)</b>							
- Rated motor current $I_M^{(2)}$ , starting time 15 s	A	29 / 26 / 23	36 / 32.5 / 29	47 / 42 / 37	57 / 51 / 45	77 / 68 / 59	93 / 82 / 72
- Starts per hour <sup>3)</sup>	1/h	13	9	13	13	13	13
- Rated motor current $I_M^{(2)}$ , starting time 30 s	A	29 / 26 / 23	36 / 32.5 / 29	47 / 42 / 37	57 / 51 / 45	77 / 68 / 59	93 / 82 / 72
- Starts per hour <sup>3)</sup>	1/h	6	4	6	6	6	6
<b>• For heavy starting (CLASS 20)</b>							
- Rated motor current $I_M^{(2)}$ , starting time 20 s	A	29 / 26 / 23	36 / 32.5 / 29	47 / 42 / 37	57 / 51 / 45	77 / 68 / 59	88 / 80 / 72
- Starts per hour <sup>3)</sup>	1/h	10	6	10	10	10	10
- Rated motor current $I_M^{(2)}$ , starting time 40 s	A	29 / 26 / 23	36 / 32.5 / 29	47 / 42 / 37	57 / 51 / 45	77 / 68 / 59	88 / 80 / 72
- Starts per hour <sup>3)</sup>	1/h	4	2	4	5	1.8	0.8
<b>• For very heavy starting (CLASS 30)</b>							
- Rated motor current $I_M^{(2)}$ , starting time 30 s	A	29 / 26 / 23	36 / 32.5 / 29	47 / 42 / 37	57 / 51 / 45	65 / 60 / 54	77 / 70 / 63
- Starts per hour <sup>3)</sup>	1/h	6	4	6	6	6	6
- Rated motor current $I_M^{(2)}$ , starting time 60 s	A	29 / 26 / 23	36 / 32.5 / 29	47 / 42 / 37	57 / 51 / 45	65 / 60 / 54	77 / 70 / 63
- Starts per hour <sup>3)</sup>	1/h	1.8	0.8	3.3	1.5	2	1

<sup>1)</sup> Measurement at 60 °C according to UL/CSA not required.

<sup>2)</sup> Current limit on soft starter set to 350 %  $I_M$   
ON period = 70 %. Maximum adjustable rated motor current  $I_M$ , dependent on CLASS setting.

<sup>3)</sup> For intermittent duty S4 with ON period = 70 %,  $T_U = 40 / 50 / 60$  °C, stand-alone installation vertical. The quoted switching frequencies do not apply for automatic mode.

# SIRIUS 3RW Soft Starters

## 3RW44 for High-Feature Applications

### 3RW44

Type		3RW4434	3RW4435	3RW4436
<b>Power electronics</b>				
<b>Rated operational current <math>I_e</math></b>		113	134	162
<b>Load rating with rated operational current <math>I_e</math></b>				
• According to IEC and UL/CSA <sup>1)</sup> , for individual mounting, AC-53a - At 40 / 50 / 60 °C	A	113 / 100 / 88	134 / 117 / 100	162 / 145 / 125
<b>Smallest adjustable rated motor current <math>I_M</math></b>	A	22	26	32
For the motor overload protection				
<b>Power loss</b>				
• In operation after completed starting with uninterrupted rated operational current (40 / 50 / 60°C) approx.	W	64 / 58 / 53	76 / 67 / 58	95 / 83 / 71
• During starting with current limit set to 350 % $I_M$ (40 / 50 / 60 °C)	W	1350 / 1140 / 970	1700 / 1400 / 1140	2460 / 1980 / 1620
<b>Permissible rated motor current and starts per hour at 40 °C / 50 °C / 60 °C</b>				
<b>• For normal starting (CLASS 5)</b>				
- Rated motor current $I_M^{(2)}$ , starting time 5 s	A	113 / 100 / 88	134 / 117 / 100	162 / 145 / 125
- Starts per hour <sup>3)</sup>	1/h	41	39	41
- Rated motor current $I_M^{(2)}$ , starting time 10 s	A	113 / 100 / 88	134 / 117 / 100	162 / 145 / 125
- Starts per hour <sup>3)</sup>	1/h	20	15	20
<b>• For normal starting (CLASS 10)</b>				
- Rated motor current $I_M^{(2)}$ , starting time 10 s	A	113 / 100 / 88	134 / 117 / 100	162 / 145 / 125
- Starts per hour <sup>3)</sup>	1/h	20	15	20
- Rated motor current $I_M^{(2)}$ , starting time 20 s	A	113 / 100 / 88	134 / 117 / 100	162 / 145 / 125
- Starts per hour <sup>3)</sup>	1/h	9	6	7
<b>• For normal starting (CLASS 15)</b>				
- Rated motor current $I_M^{(2)}$ , starting time 15 s	A	113 / 100 / 88	134 / 117 / 100	162 / 145 / 125
- Starts per hour <sup>3)</sup>	1/h	13	9	12
- Rated motor current $I_M^{(2)}$ , starting time 30 s	A	113 / 100 / 883	134 / 117 / 100	162 / 145 / 125
- Starts per hour <sup>3)</sup>	1/h	6	6	1
<b>• For heavy starting (CLASS 20)</b>				
- Rated motor current $I_M^{(2)}$ , starting time 20 s	A	106 / 97 / 88	125 / 113 / 100	147 / 134 / 122
- Starts per hour <sup>3)</sup>	1/h	9	9	10
- Rated motor current $I_M^{(2)}$ , starting time 40 s	A	106 / 97 / 88	125 / 113 / 100	147 / 134 / 122
- Starts per hour <sup>3)</sup>	1/h	1.5	2	1
<b>• For very heavy starting (CLASS 30)</b>				
- Rated motor current $I_M^{(2)}$ , starting time 30 s	A	91 / 84 / 76	110 / 100 / 90	120 / 110 / 100
- Starts per hour <sup>3)</sup>	1/h	6	6	6
- Rated motor current $I_M^{(2)}$ , starting time 60 s	A	91 / 84 / 76	110 / 100 / 90	120 / 110 / 100
- Starts per hour <sup>3)</sup>	1/h	2	2	2

<sup>1)</sup> Measurement at 60 °C according to UL/CSA not required.

<sup>2)</sup> Current limit on soft starter set to 350 %  $I_M$ , ON period = 70 %. Maximum adjustable rated motor current  $I_M$ , dependent on CLASS setting.

<sup>3)</sup> For intermittent duty S4 with ON period = 70 %,  $T_U = 40 / 50 / 60$  °C, stand-alone installation vertical. The quoted switching frequencies do not apply for automatic mode.



# SIRIUS 3RW Soft Starters

## 3RW44 for High-Feature Applications

3RW44

Type		3RW4443	3RW4444	3RW4445	3RW4446	3RW4447
<b>Power electronics</b>						
<b>Rated operational current <math>I_e</math></b>		203	250	313	356	432
<b>Load rating with rated operational current <math>I_e</math></b>						
• According to IEC and UL/CSA <sup>1)</sup> , for individual mounting, AC-53a - At 40 / 50 / 60 °C	A	203 / 180 / 156	250 / 215 / 185	313 / 280 / 250	356 / 315 / 280	432 / 385 / 335
<b>Smallest adjustable rated motor current <math>I_M</math></b>	A	40	50	62	71	86
For the motor overload protection						
<b>Power loss</b>						
• In operation after completed starting with uninterrupted rated operational current (40 / 50 / 60°C) approx.	W	89 / 81 / 73	110 / 94 / 83	145 / 126 / 110	174 / 147 / 126	232 / 194 / 159
• During starting with current limit set to 350 % $I_M$ (40 / 50 / 60 °C)	W	3350/2600/2150	4000/2900/2350	4470/4000/3400	5350/4050/3500	5860/5020/4200
<b>Permissible rated motor current and starts per hour at 40 °C / 50 °C / 60 °C</b>						
<b>• For normal starting (CLASS 5)</b>						
- Rated motor current $I_M^{(2)}$ , starting time 5 s - Starts per hour <sup>3)</sup>	A 1/h	203 / 180 / 156 41	250 / 215 / 185 41	313 / 280 / 250 41	356 / 315 / 280 41	432 / 385 / 335 39
- Rated motor current $I_M^{(2)}$ , starting time 10 s - Starts per hour <sup>3)</sup>	A 1/h	203 / 180 / 156 20	250 / 215 / 185 20	313 / 280 / 250 19	356 / 315 / 280 17	432 / 385 / 335 16
<b>• For normal starting (CLASS 10)</b>						
- Rated motor current $I_M^{(2)}$ , starting time 10 s - Starts per hour <sup>3)</sup>	A 1/h	203 / 180 / 156 20	250 / 215 / 185 20	313 / 280 / 250 19	356 / 315 / 280 17	432 / 385 / 335 16
- Rated motor current $I_M^{(2)}$ , starting time 20 s - Starts per hour <sup>3)</sup>	A 1/h	203 / 180 / 156 9	250 / 215 / 185 10	313 / 280 / 250 6	356 / 315 / 280 4	432 / 385 / 335 5
<b>• For normal starting (CLASS 15)</b>						
- Rated motor current $I_M^{(2)}$ , starting time 15 s - Starts per hour <sup>3)</sup>	A 1/h	203 / 180 / 156 13	240 / 215 / 185 13	313 / 280 / 250 10	325 / 295 / 265 13	402 / 385 / 335 11
- Rated motor current $I_M^{(2)}$ , starting time 30 s - Starts per hour <sup>3)</sup>	A 1/h	203 / 180 / 156 3	240 / 215 / 185 6	313 / 280 / 250 1	325 / 295 / 265 2	402 / 385 / 335 1
<b>• For heavy starting (CLASS 20)</b>						
- Rated motor current $I_M^{(2)}$ , starting time 20 s - Starts per hour <sup>3)</sup>	A 1/h	195 / 175 / 155 10	215 / 195 / 180 10	275 / 243 / 221 10	285 / 263 / 240 10	356 / 326 / 295 10
- Rated motor current $I_M^{(2)}$ , starting time 40 s - Starts per hour <sup>3)</sup>	A 1/h	195 / 175 / 155 1	215 / 195 / 180 5	275 / 243 / 221 1	285 / 263 / 240 3	356 / 326 / 295 1
<b>• For very heavy starting (CLASS 30)</b>						
- Rated motor current $I_M^{(2)}$ , starting time 30 s - Starts per hour <sup>3)</sup>	A 1/h	162 / 148 / 134 6	180 / 165 / 150 6	220 / 201 / 182 6	240 / 223 / 202 6	285 / 260 / 235 6
- Rated motor current $I_M^{(2)}$ , starting time 60 s - Starts per hour <sup>3)</sup>	A 1/h	162 / 148 / 134 3	180 / 165 / 150 3	220 / 201 / 182 3	240 / 223 / 202 2	285 / 260 / 235 1

<sup>1)</sup> Measurement at 60 °C according to UL/CSA not required.

<sup>2)</sup> Current limit on soft starter set to 350 %  $I_M$ ,  
ON period = 70 %. Maximum adjustable rated motor current  $I_M$ ,  
dependent on CLASS setting.

<sup>3)</sup> For intermittent duty S4 with ON period = 70 %,  $T_u = 40 / 50 / 60$  °C, stand-alone installation vertical. The quoted switching frequencies do not apply for automatic mode.

# SIRIUS 3RW Soft Starters

## 3RW44 for High-Feature Applications

### 3RW44

Type		3RW4453	3RW4454	3RW4455	3RW4456	3RW4457	3RW4458	3RW4465	3RW4466
<b>Power electronics</b>									
<b>Rated operational current <math>I_e</math></b>		551	615	693	780	880	970	1076	1214
<b>Load rating with rated operational current <math>I_e</math></b>									
• According to IEC and UL/CSA <sup>1)</sup> , for individual mounting, AC-53a									
- At 40 / 50 / 60 °C	A	551/494/438	615/551/489	693/615/551	780/693/615	880/780/693	970/850/760	1076/970/880	1214/1076/970
<b>Smallest adjustable rated motor current <math>I_M</math></b>	A	110	123	138	156	176	194	215	242
For the motor overload protection									
<b>Power loss</b>									
• In operation after completed starting with uninterrupted rated operational current (40 / 50 / 60°C) approx.	W	159/135/113	186/156/130	220/181/152	214/176/146	250/204/168	270/215/179	510/420/360	630/510/420
• During starting with current limit set to 350 % $I_M$									
- At 40 °C	W	7 020	8 100	9 500	11 100	13 100	15 000	15 000	17 500
- At 50 °C	W	6 111	7 020	8 100	9 500	11 000	12 500	13 000	15 000
- At 60 °C	W	5 263	5 996	7 020	8 100	8 100	10 700	11 500	13 000
<b>Permissible rated motor current and starts per hour at 40 °C / 50 °C / 60 °C</b>									
<b>• For normal starting (CLASS 5)</b>									
- Rated motor current $I_M^{(2)}$ , starting time 5 s	A	551/494/438	615/551/489	693/615/551	780/693/615	880/780/693	970/850/760	1076/970/880	1214/1076/970
- Starts per hour <sup>3)</sup>	1/h	41	41	37	33	22	17	30	20
- Rated motor current $I_M^{(2)}$ , starting time 10 s	A	551/494/438	615/551/489	693/615/551	780/693/615	880/780/693	970/850/760	1076/970/880	1214/1076/970
- Starts per hour <sup>3)</sup>	1/h	20	20	16	13	8	5	10	6
<b>• For normal starting (CLASS 10)</b>									
- Rated motor current $I_M^{(2)}$ , starting time 10 s	A	551/494/438	615/551/489	693/615/551	780/693/615	880/780/693	970/850/760	1076/970/880	1214/1076/970
- Starts per hour <sup>3)</sup>	1/h	20	20	16	13	8	5	11	6
- Rated motor current $I_M^{(2)}$ , starting time 20 s	A	551/494/438	615/551/489	693/615/551	780/693/615	880/780/693	970/850/760	1076/970/880	1214/1076/970
- Starts per hour <sup>3)</sup>	1/h	10	9	6	4	0.3	0.3	3	0.5
<b>• For normal starting (CLASS 15)</b>									
- Rated motor current $I_M^{(2)}$ , starting time 15 s	A	551/494/438	615/551/489	666/615/551	723/693/615	780/710/650	821/755/693	1020/950/850	1090/1000/920
- Starts per hour <sup>3)</sup>	1/h	13	13	11	9	8	8	7	5
- Rated motor current $I_M^{(2)}$ , starting time 30 s	A	551/494/438	615/551/489	666/615/551	723/693/615	780/710/650	821/755/693	1020/950/850	1090/1000/920
- Starts per hour <sup>3)</sup>	1/h	6	4	3	1	0.4	0.5	1	1
<b>• For heavy starting (CLASS 20)</b>									
- Rated motor current $I_M^{(2)}$ , starting time 20 s	A	551/494/438	591/551/489	633/615/551	670/634/576	710/650/590	740/685/630	970/880/810	1030/940/860
- Starts per hour <sup>3)</sup>	1/h	10	10	7	8	8	9	7	5
- Rated motor current $I_M^{(2)}$ , starting time 40 s	A	551/494/438	591/551/489	633/615/551	670/634/576	710/650/590	740/685/630	970/880/810	1030/940/860
- Starts per hour <sup>3)</sup>	1/h	4	2	1	1	0.4	1	1	1
<b>• For very heavy starting (CLASS 30)</b>									
- Rated motor current $I_M^{(2)}$ , starting time 30 s	A	500/480/438	525/489/455	551/520/480	575/540/490	600/550/500	630/580/530	880/810/740	920/850/780
- Starts per hour <sup>3)</sup>	1/h	6	6	6	6	6	6	6	6
- Rated motor current $I_M^{(2)}$ , starting time 60 s	A	500/480/438	525/489/455	551/520/480	575/540/490	600/550/500	630/580/530	880/810/740	920/850/780
- Starts per hour <sup>3)</sup>	1/h	2	1	1	1	1.5	1	1	1

<sup>1)</sup> Measurement at 60 °C according to UL/CSA not required.

<sup>2)</sup> Current limit on soft starter set to 350 %  $I_M$ , ON period = 70 %. Maximum adjustable rated motor current  $I_M$ , dependent on CLASS setting.

<sup>3)</sup> For intermittent duty S4 with ON period = 70 %,  $T_U = 40 / 50 / 60$  °C, stand-alone installation vertical. The quoted switching frequencies do not apply for automatic mode.

# SIRIUS 3RW Soft Starters

## 3RW44 for High-Feature Applications

3RW44

### Motor feeders with soft starters

The type of coordination according to which the motor feeder with soft starter is mounted depends on the application-specific requirements. Normally, fuseless mounting (combination of motor starter protector/circuit breaker and soft starter) is sufficient.

If type of coordination "2" is to be fulfilled, semiconductor fuses must be fitted in the motor feeder.

T<sub>OC</sub> 1

Type of coordination "1" according to IEC 60947-4-1: After a short-circuit incident, the unit is defective and therefore unsuitable for further use (protection of persons and system guaranteed).

T<sub>OC</sub> 2

Type of coordination "2" according to IEC 60947-4-1: After a short-circuit incident the unit is suitable for further use (protection of persons and system guaranteed).

The type of coordination refers to soft starters in combination with the stipulated protective device (motor starter protector/circuit breaker/fuse), not to any additional components in the feeder.

The types of coordination are indicated in the corresponding tables by the symbols shown on orange backgrounds.

### Inline circuit fuseless version

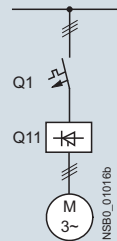

Soft starters		Motor starter protectors <sup>1)</sup>	
Q11 Type	Nominal current A	Q1 Type	Rated current A
Type of coordination "1": 3RW4422 ... 3RW4427: $I_q = 32$ kA; 3RW4434 and 3RW4435: $I_q = 16$ kA; 3RW4436 ... 3RW4466: $I_q = 65$ kA			
3RW4422	29	3RV1042-4HA10	50
3RW4423	36	3RV1042-4JA10	63
3RW4424	47	3RV1042-4KA10	75
3RW4425	57	3RV1042-4LA10	90
3RW4426	77	3RV1042-4MA10	100
3RW4427	93	3RV1042-4MA10	100
3RW4434	113	3VL1716-2DD36	160
3RW4435	134	3VL1716-2DD36	160
3RW4436	162	3VL3725-2DC36	250
3RW4443	203	3VL4731-3DC36	315
3RW4444	250	3VL4731-3DC36	315
3RW4445	313	3VL4740-3DC36	400
3RW4446	356	3VL4740-3DC36	400
3RW4447	432	3VL5750-3DC36	500
3RW4453	551	3VL6780-3SB36	800
3RW4454	615	3VL6780-3SB36	800
3RW4455	693	3VL6780-3SB36	800
3RW4456	780	3VL7710-3SB36	1000
3RW4457	880	3VL7710-3SB36	1000
3RW4458	970	3VL7712-3SB36	1250
3RW4465	1076	3VL7712-3SB36	1250
3RW4466	1214	3VL7712-3SB36	1250

<sup>1)</sup> The rated motor current must be considered when selecting the devices.

# SIRIUS 3RW Soft Starters

## 3RW44 for High-Feature Applications

3RW44

Inline circuit fused version (line protection only)

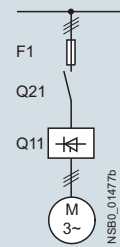

Soft starters Q11 Type	Nominal current A	Line protection, maximum			Line contactor up to 400 V (optional) Q21 Type	Braking contactors <sup>1)2)</sup> (example circuit see manual 3RW44 <sup>4)</sup> ) Q91 Type      Q92 Type	
		690 V +5 % F1 Type	Rated current A	Size			
<b>Type of coordination 1<sup>3)</sup>: <math>I_q = 65 \text{ kA}</math></b>							
3RW4422	29	3NA3820-6	50	00	3RT1034	3RT2526	--
3RW4423	36	3NA3822-6	63	00	3RT1035	3RT2526	--
3RW4424	47	3NA3824-6	80	00	3RT1036	3RT1535	--
3RW4425	57	3NA3830-6	100	00	3RT1044	3RT1535	--
3RW4426	77	3NA3132-6	125	1	3RT1045	3RT2024	3RT1035
3RW4427	93	3NA3136-6	160	1	3RT1046	3RT2025	3RT1036
3RW4434	113	3NA3244-6	250	2	3RT1054	3RT1034	3RT1044
3RW4435	134	3NA3244-6	250	2	3RT1055	3RT1036	3RT1045
3RW4436	162	3NA3365-6	500	3	3RT1056	3RT1044	3RT1045
3RW4443	203	2 x 3NA3354-6	2 x 355	3	3RT1064	3RT1044	3RT1054
3RW4444	250	2 x 3NA3354-6	2 x 355	3	3RT1065	3RT1044	3RT1055
3RW4445	313	2 x 3NA3365-6	2 x 500	3	3RT1075	3RT1054	3RT1056
3RW4446	356	2 x 3NA3365-6	2 x 500	3	3RT1075	3RT1054	3RT1056
3RW4447	432	2 x 3NA3365-6	2 x 500	3	3RT1076	3RT1055	3RT1064
3RW4453	551	2 x 3NA3365-6	2 x 500	3	3TF68	3RT1064	3RT1066
3RW4454	615	2 x 3NA3365-6	2 x 500	3	3TF68	3RT1064	3RT1075
3RW4455	693	2 x 3NA3365-6	2 x 500	3	3TF69	3RT1065	3RT1075
3RW4456	780	2 x 3NA3365-6	2 x 500	3	3TF69	3RT1065	3RT1075
3RW4457	880	2 x 3NA3365-6	2 x 500	3		3RT1075	3RT1076
3RW4458	970	3 x 3NA3365-6	3 x 500	3		3RT1075	3RT1076
3RW4465	1076	3 x 3NA3365-6	3 x 500	3		3RT1075	3TF68
3RW4466	1214	3 x 3NA3365-6	3 x 500	3		3RT1076	3TF68

1) If the ramp-down function "Combined braking" is selected, no braking contactor is required.  
If the ramp-down function "DC braking" is selected, a braking contactor must be used in addition (see table for type).  
For applications with large centrifugal masses ( $J_{Load} > J_{Motor}$ ) we recommend the function "DC braking".

2) Additional auxiliary relay K4:  
LZS:RT4A4T30  
(3RW44 soft starter with rated control supply voltage 230 V AC),  
LZS:RT4A4S15  
(3RW44 soft starter with rated control supply voltage 115 V AC).

3) The type of coordination "1" refers to soft starters in combination with the stipulated protective device (motor starter protector/fuse), not to any additional components in the feeder.

4) <http://support.automation.siemens.com/WWW/view/en/21772518>

# SIRIUS 3RW Soft Starters

## 3RW44 for High-Feature Applications

3RW44

Inline circuit fused version with 3NE1 SITOR all-range fuse (semiconductor and line protection)

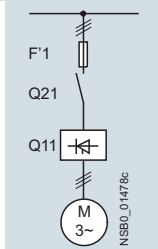

Matching fuse bases see  
 Catalog LV 10 → "Switch Disconnectors" and  
 Catalog LV 10 → "Fuse Systems"  
 → "SITOR Semiconductor Fuses"  
 or visit [www.siemens.com/sitor](http://www.siemens.com/sitor)

Soft starters	Nominal current	All-range fuses			Line contactor up to 400 V (optional)	Braking contactors <sup>1)2)</sup>		
		F1 Type	Rated current A	Voltage V		Size	Q91 Type	Q92 Type
Q11 Type	A	F1 Type	A	V	Q21 Type	Q91 Type	Q92 Type	
<b>Type of coordination 2<sup>3)</sup>: <math>I_q = 65 \text{ kA}</math></b>								
<b>3RW4422</b>	29	3NE1020-2	80	690 +5 %	00	3RT1034	3RT2526	--
<b>3RW4423</b>	36	3NE1020-2	80	690 +5 %	00	3RT1035	3RT2526	--
<b>3RW4424</b>	47	3NE1021-2	100	690 +5 %	00	3RT1036	3RT1535	--
<b>3RW4425</b>	57	3NE1022-2	125	690 +5 %	00	3RT1044	3RT1535	--
<b>3RW4426</b>	77	3NE1022-2	125	690 +5 %	00	3RT1045	3RT2024	3RT1035
<b>3RW4427</b>	93	3NE1224-2	160	690 +5 %	1	3RT1046	3RT2025	3RT1036
<b>3RW4434</b>	113	3NE1225-2	200	690 +5 %	1	3RT1054	3RT1034	3RT1044
<b>3RW4435</b>	134	3NE1227-2	250	690 +5 %	1	3RT1055	3RT1036	3RT1045
<b>3RW4436</b>	162	3NE1227-2	250	690 +5 %	1	3RT1056	3RT1044	3RT1045
<b>3RW4443</b>	203	3NE1230-2	315	600 +10 %	1	3RT1064	3RT1044	3RT1054
<b>3RW4444</b>	250	3NE1331-2	350	460 +10 %	2	3RT1065	3RT1044	3RT1055
<b>3RW4445</b>	313	3NE1333-2	450	690 +5 %	2	3RT1075	3RT1054	3RT1056
<b>3RW4446</b>	356	3NE1334-2	500	690 +5 %	2	3RT1075	3RT1054	3RT1056
<b>3RW4447</b>	432	3NE1435-2	560	690 +5 %	3	3RT1076	3RT1055	3RT1064
<b>3RW4453</b>	551	2 x 3NE1334-2	500	690 +10 %	2	3TF68	3RT1064	3RT1066
<b>3RW4454</b>	615	2 x 3NE1334-2	500	690 +10 %	2	3TF68	3RT1064	3RT1075
<b>3RW4455</b>	693	2 x 3NE1334-2	500	690 +10 %	2	3TF69	3RT1065	3RT1075
<b>3RW4456</b>	780	2 x 3NE1435-2	560	690 +10 %	3	3TF69	3RT1065	3RT1075
<b>3RW4457</b>	880	2 x 3NE1435-2	560	690 +10 %	3		3RT1075	3RT1076
<b>3RW4458</b>	970	2 x 3NE1435-2	560	690 +10 %	3		3RT1075	3RT1076
<b>3RW4465</b>	1076	3 x 3NE1334-2	500	690 +10 %	2		3RT1075	3TF68
<b>3RW4466</b>	1214	3 x 3NE1435-2	560	690 +10 %	3		3RT1076	3TF68

1) If the ramp-down function "Combined braking" is selected, no braking contactor is required.  
 If the ramp-down function "DC braking" is selected, a braking contactor must be used in addition (see table for type).  
 For applications with large centrifugal masses ( $J_{Load} > J_{Motor}$ ) we recommend the function "DC braking".

2) Additional auxiliary relay K4:  
 LZS:RT4A4T30  
 (3RW44 soft starter with rated control supply voltage 230 V AC),  
 LZS:RT4A4S15  
 (3RW44 soft starter with rated control supply voltage 115 V AC).

3) The type of coordination "2" refers to soft starters in combination with the stipulated protective device (motor starter protector/fuse), not to any additional components in the feeder.

4) <http://support.automation.siemens.com/WWW/view/en/21772518>

# SIRIUS 3RW Soft Starters

## 3RW44 for High-Feature Applications

### 3RW44

**Inline circuit fused version with 3NE or 3NC SITOR semiconductor fuse**  
(semiconductor protection by fuse, line and overload protection by motor starter protecto )

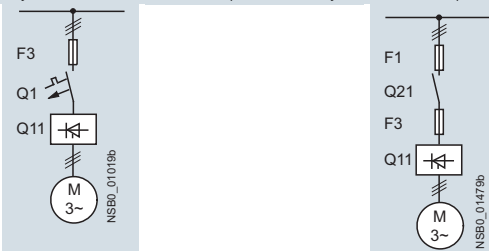

Matching fuse bases see  
Catalog LV 10 → "Switch Disconnectors"  
and Catalog LV 10 → "Fuse Systems"  
→ "SITOR Semiconductor Fuses"  
or visit [www.siemens.com/sitor](http://www.siemens.com/sitor)

Soft starters Q11 Type	Nom. curr. A	Semiconductor fuses, minimum			Semiconductor fuses, maximum			Semiconductor fuses (cylinder)		
		F3 Type	Rated current A	Size	F3 Type	Rated current A	Size	F3 Type	Rated current A	Size
<b>Type of coordination 2<sup>3)</sup>: I<sub>q</sub> = 65 kA</b>										
3RW4422	29	3NE4120	80	0	3NE4121	100	0	3NC2280	80	22 x 58
3RW4423	36	3NE4121	100	0	3NE4121	100	0	3NC2200	100	22 x 58
3RW4424	47	3NE4121	100	0	3NE4122	125	0	3NC2200	100	22 x 58
3RW4425	57	3NE4122	125	0	3NE4124	160	0			
3RW4426	77	3NE4124	160	0	3NE4124	160	0			
3RW4427	93	3NE3224	160	1	3NE3332-0B	400	2			
3RW4434	113	3NE3225	200	1	3NE3335	560	2			
3RW4435	134	3NE3225	200	1	3NE3335	560	2			
3RW4436	162	3NE3227	250	1	3NE3333	450	2			
3RW4443	203	3NE3230-0B	315	1	3NE3333	450	2			
3RW4444	250	3NE3230-0B	315	1	3NE3333	450	2			
3RW4445	313	3NE3233	450	1	3NE3336	630	2			
3RW4446	356	3NE3333	450	2	3NE3336	630	2			
3RW4447	432	3NE3335	560	2	3NE3338-8	800	2			
3RW4453	551	2 x 3NE3335	560	2	3 x 3NE3334-0B	500	2			
3RW4454	615	2 x 3NE3335	560	2	3 x 3NE3334-0B	500	2			
3RW4455	693	2 x 3NE3335	560	2	3 x 3NE3334-0B	500	2			
3RW4456	780	2 x 3NE3336	630	2	2 x 3NE3340-8	900	2			
3RW4457	880	2 x 3NE3336	630	2	2 x 3NE3340-8	900	2			
3RW4458	970	2 x 3NE3336	630	2	2 x 3NE3340-8	900	2			
3RW4465	1 076	2 x 3NE3340-8	900	2	3 x 3NE3338-8	800	2			
3RW4466	1 214	2 x 3NE3340-8	900	2	3 x 3NE3338-8	800	2			

Soft starters Q11 Type	Nom. curr. A	Line contactor up to 400 V (optional) Q21 Type	Braking contactors <sup>1)2)</sup> (example circuit see manual 3RW44 <sup>4)</sup> ) Q91 Type		Q92 Type	Motor starter protectors 440 V +10 % Q1 Type		Rated current A	Line protection, maximum 690 V +5 % F1 Type		
			Rated current A	Size		Rated current A	Size				
<b>Type of coordination 2<sup>3)</sup>: I<sub>q</sub> = 65 kA</b>											
3RW4422	29	3RT1034	3RT2526	--		3RV1041-4HA10	50	3NA3820-6	50	00	
3RW4423	36	3RT1035	3RT2526	--		3RV1041-4JA10	63	3NA3822-6	63	00	
3RW4424	47	3RT1036	3RT1535	--		3RV1041-4KA10	75	3NA3824-6	80	00	
3RW4425	57	3RT1044	3RT1535	--		3RV1041-4LA10	90	3NA3830-6	100	00	
3RW4426	77	3RT1045	3RT2024	3RT1035		3RV1041-4MA10	100	3NA3132-6	125	1	
3RW4427	93	3RT1046	3RT2025	3RT1036		3RV1041-4MA10	100	3NA3136-6	160	1	
3RW4434	113	3RT1054	3RT1034	3RT1044		3VL1716	160	3NA3244-6	250	2	
3RW4435	134	3RT1055	3RT1036	3RT1045		3VL1716	160	3NA3244-6	250	2	
3RW4436	162	3RT1056	3RT1044	3RT1045		3VL3725	250	3NA3365-6	500	3	
3RW4443	203	3RT1064	3RT1044	3RT1054		3VL4731	315	2 x 3NA3354-6	2 x 355	3	
3RW4444	250	3RT1065	3RT1044	3RT1055		3VL4731	315	2 x 3NA3354-6	2 x 355	3	
3RW4445	313	3RT1075	3RT1054	3RT1056		3VL4740	400	2 x 3NA3365-6	2 x 500	3	
3RW4446	356	3RT1075	3RT1054	3RT1056		3VL4740	400	2 x 3NA3365-6	2 x 500	3	
3RW4447	432	3RT1076	3RT1055	3RT1064		3VL5750	500	2 x 3NA3365-6	2 x 500	3	
3RW4453	551	3TF68	3RT1064	3RT1066		3VL6780	800	2 x 3NA3365-6	2 x 500	3	
3RW4454	615	3TF68	3RT1064	3RT1075		3VL6780	800	2 x 3NA3365-6	2 x 500	3	
3RW4455	693	3TF69	3RT1065	3RT1075		3VL6780	800	2 x 3NA3365-6	2 x 500	3	
3RW4456	780	3TF69	3RT1065	3RT1075		3VL7710	1 000	2 x 3NA3365-6	2 x 500	3	
3RW4457	880		3RT1075	3RT1076		3VL7710	1 000	2 x 3NA3365-6	2 x 500	3	
3RW4458	970		3RT1075	3RT1076		3VL7712	1 250	3 x 3NA3365-6	3 x 500	3	
3RW4465	1 076		3RT1075	3TF68		3VL7712	1 250	3 x 3NA3365-6	3 x 500	3	
3RW4466	1 214		3RT1076	3TF68		3VL7712	1 250	3 x 3NA3365-6	3 x 500	3	

1) If the ramp-down function "Combined braking" is selected, no braking contactor is required. If the ramp-down function "DC braking" is selected, a braking contactor must be used in addition (see table for type).  
For applications with large centrifugal masses ( $J_{Load} > J_{Motor}$ ) we recommend the function "DC braking".

2) Additional auxiliary relay K4: LZS:RT4A4T30 (3RW44 soft starter with rated control supply voltage 230 V AC), LZS:RT4A4S15 (3RW44 soft starter with rated control supply voltage 115 V AC).

3) The type of coordination "2" refers to soft starters in combination with the stipulated protective device (motor starter protector/fuse), not to any additional components in the feeder.

4) <http://support.automation.siemens.com/WW/view/en/21772518>

# SIRIUS 3RW Soft Starters

## 3RW44 for High-Feature Applications

3RW44

### Inside-delta circuit fused version with 3NE or 3NC SITOR fuses

(semiconductor protection by fuse, line and overload protection by motor starter protector)

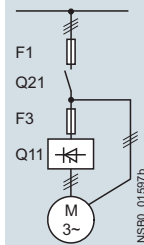
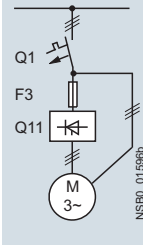

Matching fuse bases see  
Catalog LV 10 → "Switch Disconnectors"  
and Catalog LV 10 → "Fuse Systems"  
→ "SITOR Semiconductor Fuses"  
or visit [www.siemens.com/sitor](http://www.siemens.com/sitor)

Soft starters	Nominal current	Semiconductor fuses, minimum			Semiconductor fuses, maximum			Semiconductor fuses (cylinder)		
		Q11 Type	F3 Type	Rated current A	Size	F3 Type	Rated current A	Size	F3 Type	Rated current A
<b>Type of coordination 2<sup>1)</sup></b>										
3RW4422	50	3NE4120	80	0	3NE4121	100	0	3NC2280	80	22 x 58
3RW4423	62	3NE4121	100	0	3NE4121	100	0	3NC2200	100	22 x 58
3RW4424	81	3NE4121	100	0	3NE4122	125	0	3NC2200	100	22 x 58
3RW4425	99	3NE4122	125	0	3NE4124	160	0			
3RW4426	133	3NE4124	160	0	3NE4124	160	0			
3RW4427	161	3NE3224	160	1	3NE3332-0B	400	2			
3RW4434	196	3NE3225	200	1	3NE3335	560	2			
3RW4435	232	3NE3225	200	1	3NE3335	560	2			
3RW4436	281	3NE3227	250	1	3NE3333	450	2			
3RW4443	352	3NE3230-0B	315	1	3NE3333	450	2			
3RW4444	433	3NE3230-0B	315	1	3NE3333	450	2			
3RW4445	542	3NE3233	450	1	3NE3336	630	2			
3RW4446	617	3NE3333	450	2	3NE3336	630	2			
3RW4447	748	3NE3335	560	2	3NE3338-8	800	2			
3RW4453	954	2 x 3NE3335	560	2	3 x 3NE3334-0B	500	2			
3RW4454	1 065	2 x 3NE3335	560	2	3 x 3NE3334-0B	500	2			
3RW4455	1 200	2 x 3NE3335	560	2	3 x 3NE3334-0B	500	2			
3RW4456	1 351	2 x 3NE3336	630	2	2 x 3NE3340-8	900	2			
3RW4457	1 524	2 x 3NE3336	630	2	3 x 3NE3340-8	900	2			
3RW4458	1 680	2 x 3NE3336	630	2	3 x 3NE3340-8	900	2			
3RW4465	1 864	2 x 3NE3340-8	900	2	3 x 3NE3338-8	800	2			
3RW4466	2 103	2 x 3NE3340-8	900	2	3 x 3NE3338-8	800	2			

Soft starters	Nominal current	Line contactor up to 400 V (optional)	Motor starter protectors		Line protection, maximum		
			Q1 Type	Rated current A	F1 Type	Rated current A	Size
<b>Type of coordination 2<sup>1)</sup></b>							
3RW4422	50	3RT1036-1AP04	3RV1042-4KA10	75	3NA3824-6	80	00
3RW4423	62	3RT1044-1AP04	3RV1042-4LA10	90	3NA3830-6	100	00
3RW4424	81	3RT1046-1AP04	3RV1042-4MA10	100	3NA3132-6	125	1
3RW4425	99	3RT1054-1AP36	3VL2716	160	3NA3136-6	160	1
3RW4426	133	3RT1055-6AP36	3VL2716	160	3NA3240-6	200	2
3RW4427	161	3RT1056-6AP36	3VL3720	200	3NA3244-6	250	2
3RW4434	196	3RT1064-6AP36	3VL3725	250	3NA3360-6	400	3
3RW4435	232	3RT1065-6AP36	3VL4731	315	3NA3360-6	400	3
3RW4436	281	3RT1066-6AP36	3VL4740	400	2 x 3NA3360-6	2 x 400	3
3RW4443	352	3RT1075-6AP36	3VL4740	400	2 x 3NA3365-6	2 x 500	3
3RW4444	433	3RT1076-6AP36	3VL5750	500	2 x 3NA3365-6	2 x 500	3
3RW4445	542	3TF6844-OCM7	3VL5763	630	3 x 3NA3365-6	3 x 500	3
3RW4446	617	3TF6844-OCM7	3VL6780	800	3 x 3NA3365-6	3 x 500	3
3RW4447	748	3TF69	3VL6780	800	3 x 3NA3365-6	3 x 500	3
3RW4453	954		3VL7710	1 000	3 x 3NA3365-6	3 x 500	3
3RW4454	1 065		3VL7712	1 250	3 x 3NA3365-6	3 x 500	3
3RW4455	1 200		3VL8716	1 600	3 x 3NA3365-6	3 x 500	3
3RW4456	1 351		3VL8716	1 600	3 x 3NA3372	3 x 630	3
3RW4457	1 524		3VL8716	1 600	3 x 3NA3372	3 x 630	3
3RW4458	1 680		3WL1220	2 000	2 x 3NA3480	2 x 1000	4
3RW4465	1 864		3WL1225	2 500	2 x 3NA3482	2 x 1250	4
3RW4466	2 103		3WL1225	2 500	2 x 3NA3482	2 x 1250	4

<sup>1)</sup> The type of coordination "2" refers to soft starters in combination with the stipulated protective device (motor starter protector/fuse), not to any additional components in the feeder.  
If the F3 semiconductor fuse is not used, the type of coordination "2" is reduced to type of coordination "1" for soft starters in combination with the stipulated protective device.

# SIRIUS 3RW Soft Starters

## 3RW44 for High-Feature Applications

3RW44

### Selection and ordering data

#### SIRIUS 3RW44 for normal starting (CLASS 10) in inline circuit



3RW442.

3RW443.

3RW444.

3RW445.

3RW446.

3RW ambient temperature 40 °C					3RW ambient temperature 50 °C					DT <sup>1)</sup>	Normal starting (CLASS 10) in inline circuit	Configurator	PU (UNIT, SET, M)	PS*	PG	
Rated values of three-phase motors					Rated values of three-phase motors											
Operat. current I <sub>e</sub>	Rating at operational voltage U <sub>e</sub>					Operat. current I <sub>e</sub>	Rating at operational voltage U <sub>e</sub>					Article No.	Price per PU			
	230 V	400 V	500 V	690 V	1000 V		200 V	230 V	460 V	575 V	A					
29	5.5	15	--	--	--	26	7.5	7.5	15	--	B	3RW4422-□BC□4	1	1 unit	42H	
36	7.5	18.5	--	--	--	32	10	10	20	--	B	3RW4423-□BC□4	1	1 unit	42H	
47	11	22	--	--	--	42	10	15	25	--	B	3RW4424-□BC□4	1	1 unit	42H	
57	15	30	--	--	--	51	15	15	30	--	B	3RW4425-□BC□4	1	1 unit	42H	
77	18.5	37	--	--	--	68	20	20	50	--	B	3RW4426-□BC□4	1	1 unit	42H	
93	22	45	--	--	--	82	25	25	60	--	B	3RW4427-□BC□4	1	1 unit	42H	
<b>Article No. supplement for connection types</b>																
• With screw terminals																
• With spring-type terminals																
113	30	55	--	--	--	100	30	30	75	--	B	3RW4434-□BC□4	1	1 unit	42H	
134	37	75	--	--	--	117	30	40	75	--	B	3RW4435-□BC□4	1	1 unit	42H	
162	45	90	--	--	--	145	40	50	100	--	B	3RW4436-□BC□4	1	1 unit	42H	
203	55	110	--	--	--	180	50	60	125	--	B	3RW4443-□BC□4	1	1 unit	42H	
250	75	132	--	--	--	215	60	75	150	--	B	3RW4444-□BC□4	1	1 unit	42H	
313	90	160	--	--	--	280	75	100	200	--	B	3RW4445-□BC□4	1	1 unit	42H	
356	110	200	--	--	--	315	100	125	250	--	B	3RW4446-□BC□4	1	1 unit	42H	
432	132	250	--	--	--	385	125	150	300	--	B	3RW4447-□BC□4	1	1 unit	42H	
551	160	315	--	--	--	494	150	200	400	--	C	3RW4453-□BC□4	1	1 unit	42H	
615	200	355	--	--	--	551	150	200	450	--	C	3RW4454-□BC□4	1	1 unit	42H	
693	200	400	--	--	--	615	200	250	500	--	C	3RW4455-□BC□4	1	1 unit	42H	
780	250	450	--	--	--	693	200	250	600	--	C	3RW4456-□BC□4	1	1 unit	42H	
880	250	500	--	--	--	780	250	300	700	--	C	3RW4457-□BC□4	1	1 unit	42H	
970	315	560	--	--	--	850	300	350	750	--	C	3RW4458-□BC□4	1	1 unit	42H	
1076	355	630	--	--	--	970	350	400	850	--	C	3RW4465-□BC□4	1	1 unit	42H	
1214	400	710	--	--	--	1076	350	450	950	--	C	3RW4466-□BC□4	1	1 unit	42H	

#### Article No. supplement for connection types

- With spring-type terminals
- With screw terminals

#### Article No. supplement for rated control supply voltage U<sub>s</sub><sup>2)</sup>

- 115 V AC
- 230 V AC

Online configurator see [www.siemens.com/sirius/configurators](http://www.siemens.com/sirius/configurators)

<sup>1)</sup> 3RW442. to ... 3RW444. soft starters with screw terminals: delivery time class ► (preferred type).

<sup>2)</sup> Control by way of the internal 24 V DC supply and direct control via PLC possible.

#### Note:

The listed motor ratings are rough guide values. The soft starter should always be designed on the basis of the required rated operational current of the motor.

The solid-state SIRIUS 3RW44 soft starters are designed for easy starting conditions. The selection and ordering data were determined for the following boundary conditions (see also the notes on page 6/6):

- Maximum starting time in s: 10
- Maximum starting current in % of motor current I<sub>e</sub>: 300
- Maximum number of starts per hour in 1/h: 5

In case of additional requirements, it may be necessary to choose a larger device. In some cases, however, the safety margins taken into account in the selection also permit the listed units to be used in boundary conditions which are slightly more demanding. Detailed technical information for a configuration which is tailored exactly to the application, see manual <http://support.automation.siemens.com/WW/view/en/21772518>



# SIRIUS 3RW Soft Starters

## 3RW44 for High-Feature Applications

3RW44

3RW ambient temperature 40 °C					3RW ambient temperature 50 °C				DT <sup>1)</sup>	Normal starting (CLASS 10) in inline circuit	PU (UNIT, SET, M)	PS*	PG		
Rated values of three-phase motors					Rated values of three-phase motors					Configurator					
Operational current $I_e$	Rating at operational voltage $U_e$					Operational current $I_e$	Rating at operational voltage $U_e$				Article No.	Price per PU			
	230 V	400 V	500 V	690 V	1000 V		200 V	230 V	460 V	575 V					
A	kW	kW	kW	kW	kW	A	hp	hp	hp	hp					
<b>Inline circuit, rated operational voltage 400 ... 600 V</b>															
29	--	15	<b>18.5</b>	--	--	26	--	--	15	<b>20</b>	B	<b>3RW4422-□BC□5</b>	1	1 unit	42H
36	--	18.5	<b>22</b>	--	--	32	--	--	20	<b>25</b>	B	<b>3RW4423-□BC□5</b>	1	1 unit	42H
47	--	22	<b>30</b>	--	--	42	--	--	25	<b>30</b>	B	<b>3RW4424-□BC□5</b>	1	1 unit	42H
57	--	30	<b>37</b>	--	--	51	--	--	30	<b>40</b>	B	<b>3RW4425-□BC□5</b>	1	1 unit	42H
77	--	37	<b>45</b>	--	--	68	--	--	50	<b>50</b>	B	<b>3RW4426-□BC□5</b>	1	1 unit	42H
93	--	45	<b>55</b>	--	--	82	--	--	60	<b>75</b>	B	<b>3RW4427-□BC□5</b>	1	1 unit	42H
<b>Article No. supplement for connection types</b>															
<ul style="list-style-type: none"> <li>• With screw terminals</li> <li>• With spring-type terminals</li> </ul>															
113	--	55	<b>75</b>	--	--	100	--	--	75	<b>75</b>	B	<b>3RW4434-□BC□5</b>	1	1 unit	42H
134	--	75	<b>90</b>	--	--	117	--	--	75	<b>100</b>	B	<b>3RW4435-□BC□5</b>	1	1 unit	42H
162	--	90	<b>110</b>	--	--	145	--	--	100	<b>125</b>	B	<b>3RW4436-□BC□5</b>	1	1 unit	42H
203	--	110	<b>132</b>	--	--	180	--	--	125	<b>150</b>	B	<b>3RW4443-□BC□5</b>	1	1 unit	42H
250	--	132	<b>160</b>	--	--	215	--	--	150	<b>200</b>	B	<b>3RW4444-□BC□5</b>	1	1 unit	42H
313	--	160	<b>200</b>	--	--	280	--	--	200	<b>250</b>	B	<b>3RW4445-□BC□5</b>	1	1 unit	42H
356	--	200	<b>250</b>	--	--	315	--	--	250	<b>300</b>	B	<b>3RW4446-□BC□5</b>	1	1 unit	42H
432	--	250	<b>315</b>	--	--	385	--	--	300	<b>400</b>	B	<b>3RW4447-□BC□5</b>	1	1 unit	42H
551	--	315	<b>355</b>	--	--	494	--	--	400	<b>500</b>	C	<b>3RW4453-□BC□5</b>	1	1 unit	42H
615	--	355	<b>400</b>	--	--	551	--	--	450	<b>600</b>	C	<b>3RW4454-□BC□5</b>	1	1 unit	42H
693	--	400	<b>500</b>	--	--	615	--	--	500	<b>700</b>	C	<b>3RW4455-□BC□5</b>	1	1 unit	42H
780	--	450	<b>560</b>	--	--	693	--	--	600	<b>750</b>	C	<b>3RW4456-□BC□5</b>	1	1 unit	42H
880	--	500	<b>630</b>	--	--	780	--	--	700	<b>850</b>	C	<b>3RW4457-□BC□5</b>	1	1 unit	42H
970	--	560	<b>710</b>	--	--	850	--	--	750	<b>900</b>	C	<b>3RW4458-□BC□5</b>	1	1 unit	42H
1076	--	630	<b>800</b>	--	--	970	--	--	850	<b>1 100</b>	C	<b>3RW4465-□BC□5</b>	1	1 unit	42H
1214	--	710	<b>900</b>	--	--	1076	--	--	950	<b>1 200</b>	C	<b>3RW4466-□BC□5</b>	1	1 unit	42H
<b>Article No. supplement for connection types</b>															
<ul style="list-style-type: none"> <li>• With spring-type terminals</li> <li>• With screw terminals</li> </ul>															
<b>Article No. supplement for rated control supply voltage <math>U_s</math><sup>2)</sup></b>															
<ul style="list-style-type: none"> <li>• 115 V AC</li> <li>• 230 V AC</li> </ul>															
Online configurator see <a href="http://www.siemens.com/sirius/configurators">www.siemens.com/sirius/configurators</a>															

<sup>1)</sup> Soft starter with screw terminals:  
3RW442. ... 3RW444. Delivery time class A,  
3RW445. ... 3RW446. Delivery time class B.

<sup>2)</sup> Control by way of the internal 24 V DC supply and direct control via PLC possible.

**Note:**

The listed motor ratings are rough guide values. The soft starter should always be designed on the basis of the required rated operational current of the motor.

The solid-state SIRIUS 3RW44 soft starters are designed for easy starting conditions. The selection and ordering data were determined for the following boundary conditions (see also the notes on page 6/6):

- Maximum starting time in s: 10
- Maximum starting current in % of motor current  $I_e$ : 300
- Maximum number of starts per hour in 1/h: 5

In case of additional requirements, it may be necessary to choose a larger device. In some cases, however, the safety margins taken into account in the selection also permit the listed units to be used in boundary conditions which are slightly more demanding. Detailed technical information for a configuration which is tailored exactly to the application, see manual <http://support.automation.siemens.com/WW/view/en/21772518>

# SIRIUS 3RW Soft Starters

## 3RW44 for High-Feature Applications

### 3RW44

3RW ambient temperature 40 °C						3RW ambient temperature 50 °C				DT	Normal starting (CLASS 10) in inline circuit	PU (UNIT, SET, M)	PS*	PG	
Rated values of three-phase motors						Rated values of three-phase motors									
Operational current $I_e$	Rating at operational voltage $U_e$					Operational current $I_e$	Rating at operational voltage $U_e$				Configurator 	Article No.	Price per PU		
	230 V	400 V	500 V	690 V	1000 V		200 V	230 V	460 V	575 V					
A	kW	kW	kW	kW	kW	A	hp	hp	hp	hp					
<b>Inline circuit, rated operational voltage 400 ... 690 V</b>															
29	--	15	18.5	<b>30</b>	--	26	--	--	15	<b>20</b>	B	<b>3RW4422-□BC□6</b>	1	1 unit	42H
36	--	18.5	22	<b>37</b>	--	32	--	--	20	<b>25</b>	B	<b>3RW4423-□BC□6</b>	1	1 unit	42H
47	--	22	30	<b>45</b>	--	42	--	--	25	<b>30</b>	B	<b>3RW4424-□BC□6</b>	1	1 unit	42H
57	--	30	37	<b>55</b>	--	51	--	--	30	<b>40</b>	B	<b>3RW4425-□BC□6</b>	1	1 unit	42H
77	--	37	45	<b>75</b>	--	68	--	--	50	<b>50</b>	B	<b>3RW4426-□BC□6</b>	1	1 unit	42H
93	--	45	55	<b>90</b>	--	82	--	--	60	<b>75</b>	B	<b>3RW4427-□BC□6</b>	1	1 unit	42H
<b>Article No. supplement for connection types</b> <ul style="list-style-type: none"> <li>• With screw terminals</li> <li>• With spring-type terminals</li> </ul>															
113	--	55	75	<b>110</b>	--	100	--	--	75	<b>75</b>	B	<b>3RW4434-□BC□6</b>	1	1 unit	42H
134	--	75	90	<b>132</b>	--	117	--	--	75	<b>100</b>	B	<b>3RW4435-□BC□6</b>	1	1 unit	42H
162	--	90	110	<b>160</b>	--	145	--	--	100	<b>125</b>	B	<b>3RW4436-□BC□6</b>	1	1 unit	42H
203	--	110	132	<b>200</b>	--	180	--	--	125	<b>150</b>	B	<b>3RW4443-□BC□6</b>	1	1 unit	42H
250	--	132	160	<b>250</b>	--	215	--	--	150	<b>200</b>	B	<b>3RW4444-□BC□6</b>	1	1 unit	42H
313	--	160	200	<b>315</b>	--	280	--	--	200	<b>250</b>	B	<b>3RW4445-□BC□6</b>	1	1 unit	42H
356	--	200	250	<b>355</b>	--	315	--	--	250	<b>300</b>	B	<b>3RW4446-□BC□6</b>	1	1 unit	42H
432	--	250	315	<b>400</b>	--	385	--	--	300	<b>400</b>	B	<b>3RW4447-□BC□6</b>	1	1 unit	42H
551	--	315	355	<b>560</b>	--	494	--	--	400	<b>500</b>	C	<b>3RW4453-□BC□6</b>	1	1 unit	42H
615	--	355	400	<b>630</b>	--	551	--	--	450	<b>600</b>	C	<b>3RW4454-□BC□6</b>	1	1 unit	42H
693	--	400	500	<b>710</b>	--	615	--	--	500	<b>700</b>	C	<b>3RW4455-□BC□6</b>	1	1 unit	42H
780	--	450	560	<b>800</b>	--	693	--	--	600	<b>750</b>	C	<b>3RW4456-□BC□6</b>	1	1 unit	42H
880	--	500	630	<b>900</b>	--	780	--	--	700	<b>850</b>	C	<b>3RW4457-□BC□6</b>	1	1 unit	42H
970	--	560	710	<b>1000</b>	--	850	--	--	750	<b>900</b>	C	<b>3RW4458-□BC□6</b>	1	1 unit	42H
1076	--	630	800	<b>1100</b>	--	970	--	--	850	<b>1100</b>	C	<b>3RW4465-□BC□6</b>	1	1 unit	42H
1214	--	710	900	<b>1200</b>	--	1076	--	--	950	<b>1200</b>	C	<b>3RW4466-□BC□6</b>	1	1 unit	42H

**Article No. supplement for connection types**

- With spring-type terminals
- With screw terminals

**Article No. supplement for rated control supply voltage  $U_s$ <sup>1)</sup>**

- 115 V AC
- 230 V AC

 Online configurator [see www.siemens.com/sirius/configurators](http://www.siemens.com/sirius/configurators)

<sup>1)</sup> Control by way of the internal 24 V DC supply and direct control via PLC possible.

**Note:**

The listed motor ratings are rough guide values. The soft starter should always be designed on the basis of the required rated operational current of the motor.

The solid-state SIRIUS 3RW44 soft starters are designed for easy starting conditions. The selection and ordering data were determined for the following boundary conditions (see also the notes on page 6/6):

- Maximum starting time in s: 10
- Maximum starting current in % of motor current  $I_e$ : 300
- Maximum number of starts per hour in 1/h: 5

In case of additional requirements, it may be necessary to choose a larger device. In some cases, however, the safety margins taken into account in the selection also permit the listed units to be used in boundary conditions which are slightly more demanding. Detailed technical information for a configuration which is tailored exactly to the application, [see manual http://support.automation.siemens.com/WW/view/en/21772518](http://support.automation.siemens.com/WW/view/en/21772518)

# SIRIUS 3RW Soft Starters

## 3RW44 for High-Feature Applications

3RW44

### SIRIUS 3RW44 for heavy starting (CLASS 20) in inline circuit



3RW442.						3RW443.						3RW444.						3RW445.		3RW4466.								
3RW ambient temperature 40 °C												3RW ambient temperature 50 °C												DT <sup>1)</sup> Heavy starting (CLASS 20) in inline circuit		PU (UNIT, SET, M)	PS*	PG
Rated values of three-phase motors												Rated values of three-phase motors												Configurator				
Operat. current $I_e$												Operat. current $I_e$												Article No.		Price per PU		
Rating at operational voltage $U_e$												Rating at operational voltage $U_e$																
230 V 400 V 500 V 690 V 1000 V												200 V 230 V 460 V 575 V																
A kW kW kW kW												A hp hp hp hp																
Inline circuit, rated operational voltage 200 ... 460 V																												
29	5.5	15	--	--	--	26	7.5	7.5	15	--	B	3RW4422-□BC□4	1	1 unit	42H													
36	7.5	18.5	--	--	--	32	10	10	20	--	B	3RW4423-□BC□4	1	1 unit	42H													
47	11	22	--	--	--	42	10	15	25	--	B	3RW4424-□BC□4	1	1 unit	42H													
57	15	30	--	--	--	51	15	15	30	--	B	3RW4425-□BC□4	1	1 unit	42H													
77	18.5	37	--	--	--	68	20	20	50	--	B	3RW4427-□BC□4	1	1 unit	42H													
<b>Article No. supplement for connection types</b>																												
<ul style="list-style-type: none"> <li>With screw terminals</li> <li>With spring-type terminals</li> </ul>																												
93	22	45	--	--	--	82	25	25	60	--	B	3RW4434-□BC□4	1	1 unit	42H													
113	30	55	--	--	--	100	30	30	75	--	B	3RW4435-□BC□4	1	1 unit	42H													
134	37	75	--	--	--	117	30	40	75	--	B	3RW4436-□BC□4	1	1 unit	42H													
162	45	90	--	--	--	145	40	50	100	--	B	3RW4443-□BC□4	1	1 unit	42H													
203	55	110	--	--	--	180	50	60	125	--	B	3RW4445-□BC□4	1	1 unit	42H													
250	75	132	--	--	--	215	60	75	150	--	B	3RW4446-□BC□4	1	1 unit	42H													
313	90	160	--	--	--	280	75	100	200	--	B	3RW4447-□BC□4	1	1 unit	42H													
356	110	200	--	--	--	315	100	125	250	--	B	3RW4447-□BC□4	1	1 unit	42H													
432	132	250	--	--	--	385	125	150	300	--	C	3RW4453-□BC□4	1	1 unit	42H													
551	160	315	--	--	--	494	150	200	400	--	C	3RW4453-□BC□4	1	1 unit	42H													
615	200	355	--	--	--	551	150	200	450	--	C	3RW4455-□BC□4	1	1 unit	42H													
693	200	400	--	--	--	615	200	250	500	--	C	3RW4457-□BC□4	1	1 unit	42H													
780	250	450	--	--	--	693	200	250	600	--	C	3RW4465-□BC□4	1	1 unit	42H													
880	250	500	--	--	--	780	250	300	700	--	C	3RW4465-□BC□4	1	1 unit	42H													
970	315	560	--	--	--	850	300	350	750	--	C	3RW4465-□BC□4	1	1 unit	42H													

#### Article No. supplement for connection types

- With spring-type terminals
- With screw terminals

#### Article No. supplement for rated control supply voltage $U_s$ <sup>2)</sup>

- 115 V AC
- 230 V AC

Online configurator see [www.siemens.com/sirius/configurators](http://www.siemens.com/sirius/configurators)

<sup>1)</sup> 3RW442. to 3RW444. soft starters with screw terminals: delivery time class ▶ (preferred type).

<sup>2)</sup> Control by way of the internal 24 V DC supply and direct control via PLC possible.

#### Note:

The listed motor ratings are rough guide values. The soft starter should always be designed on the basis of the required rated operational current of the motor.

The solid-state SIRIUS 3RW44 soft starters are designed for easy starting conditions. The selection and ordering data were determined for the following boundary conditions (see also the notes on page 6/6):

- Maximum starting time in s: 40
- Maximum starting current in % of motor current  $I_e$ : 350
- Maximum number of starts per hour in 1/h: 1

In case of additional requirements, it may be necessary to choose a larger device. In some cases, however, the safety margins taken into account in the selection also permit the listed units to be used in boundary conditions which are slightly more demanding. Detailed technical information for a configuration which is tailored exactly to the application, see manual <http://support.automation.siemens.com/WW/view/en/21772518>

# SIRIUS 3RW Soft Starters

## 3RW44 for High-Feature Applications

### 3RW44

3RW ambient temperature 40 °C						3RW ambient temperature 50 °C				DT <sup>1)</sup>	Heavy starting (CLASS 20) in inline circuit	Configurator	PU (UNIT, SET, M)	PS*	PG
Rated values of three-phase motors						Rated values of three-phase motors				Operational current I <sub>e</sub>	Rating at operational voltage U <sub>e</sub>				
Operational current I <sub>e</sub>	Rating at operational voltage U <sub>e</sub>					Operational current I <sub>e</sub>	Rating at operational voltage U <sub>e</sub>								
	230 V	400 V	500 V	690 V	1000 V		200 V	230 V	460 V	575 V					
A	kW	kW	kW	kW	kW	A	hp	hp	hp	hp					
<b>Inline circuit, rated operational voltage 400 ... 600 V</b>															
29	--	15	<b>18.5</b>	--	--	26	--	--	15	<b>20</b>	B	<b>3RW4422-□BC□5</b>	1	1 unit	42H
36	--	18.5	<b>22</b>	--	--	32	--	--	20	<b>25</b>	B	<b>3RW4423-□BC□5</b>	1	1 unit	42H
47	--	22	<b>30</b>	--	--	42	--	--	25	<b>30</b>	B	<b>3RW4424-□BC□5</b>	1	1 unit	42H
57	--	30	<b>37</b>	--	--	51	--	--	30	<b>40</b>	B	<b>3RW4425-□BC□5</b>	1	1 unit	42H
77	--	37	<b>45</b>	--	--	68	--	--	50	<b>50</b>	B	<b>3RW4427-□BC□5</b>	1	1 unit	42H
<b>Article No. supplement for connection types</b>															
<ul style="list-style-type: none"> <li>• With screw terminals</li> <li>• With spring-type terminals</li> </ul>															
93	--	45	<b>55</b>	--	--	82	--	--	60	<b>75</b>	B	<b>3RW4434-□BC□5</b>	1	1 unit	42H
113	--	55	<b>75</b>	--	--	100	--	--	75	<b>75</b>	B	<b>3RW4435-□BC□5</b>	1	1 unit	42H
134	--	75	<b>90</b>	--	--	117	--	--	75	<b>100</b>	B	<b>3RW4436-□BC□5</b>	1	1 unit	42H
162	--	90	<b>110</b>	--	--	145	--	--	100	<b>125</b>	B	<b>3RW4443-□BC□5</b>	1	1 unit	42H
203	--	110	<b>132</b>	--	--	180	--	--	125	<b>150</b>	B	<b>3RW4445-□BC□5</b>	1	1 unit	42H
250	--	132	<b>160</b>	--	--	215	--	--	150	<b>200</b>	B	<b>3RW4446-□BC□5</b>	1	1 unit	42H
313	--	160	<b>200</b>	--	--	280	--	--	200	<b>250</b>	B	<b>3RW4447-□BC□5</b>	1	1 unit	42H
356	--	200	<b>250</b>	--	--	315	--	--	250	<b>300</b>	B	<b>3RW4447-□BC□5</b>	1	1 unit	42H
432	--	250	<b>315</b>	--	--	385	--	--	300	<b>400</b>	C	<b>3RW4453-□BC□5</b>	1	1 unit	42H
551	--	315	<b>355</b>	--	--	494	--	--	400	<b>500</b>	C	<b>3RW4453-□BC□5</b>	1	1 unit	42H
615	--	355	<b>400</b>	--	--	551	--	--	450	<b>600</b>	C	<b>3RW4454-□BC□5</b>	1	1 unit	42H
693	--	400	<b>500</b>	--	--	615	--	--	500	<b>700</b>	C	<b>3RW4457-□BC□5</b>	1	1 unit	42H
780	--	450	<b>560</b>	--	--	693	--	--	600	<b>750</b>	C	<b>3RW4465-□BC□5</b>	1	1 unit	42H
880	--	500	<b>630</b>	--	--	780	--	--	700	<b>850</b>	C	<b>3RW4465-□BC□5</b>	1	1 unit	42H
970	--	560	<b>710</b>	--	--	850	--	--	750	<b>900</b>	C	<b>3RW4465-□BC□5</b>	1	1 unit	42H

1  
3

2  
6

3  
4

**Article No. supplement for connection types**

- With spring-type terminals
- With screw terminals

**Article No. supplement for rated control supply voltage U<sub>s</sub><sup>2)</sup>**

- 115 V AC
- 230 V AC

Online configurator see [www.siemens.com/sirius/configurators](http://www.siemens.com/sirius/configurators)

<sup>1)</sup> Soft starter with screw terminals:  
3RW442. to 3RW444. Delivery time class A,  
3RW445. to 3RW446. Delivery time class B.  
<sup>2)</sup> Control by way of the internal 24 V DC supply and direct control via PLC possible.

Note:

The listed motor ratings are rough guide values. The soft starter should always be designed on the basis of the required rated operational current of the motor.

The solid-state SIRIUS 3RW44 soft starters are designed for easy starting conditions. The selection and ordering data were determined for the following boundary conditions (see also the notes on page 6/6):

- Maximum starting time in s: 40
- Maximum starting current in % of motor current I<sub>e</sub>: 350
- Maximum number of starts per hour in 1/h: 1

In case of additional requirements, it may be necessary to choose a larger device. In some cases, however, the safety margins taken into account in the selection also permit the listed units to be used in boundary conditions which are slightly more demanding. Detailed technical information for a configuration which is tailored exactly to the application, see manual <http://support.automation.siemens.com/WW/view/en/21772518>

# SIRIUS 3RW Soft Starters

## 3RW44 for High-Feature Applications

3RW44

3RW ambient temperature 40 °C						3RW ambient temperature 50 °C				DT	Heavy starting (CLASS 20) in inline circuit	PU (UNIT, SET, M)	PS*	PG	
Rated values of three-phase motors						Rated values of three-phase motors					Configurator				
Operational current $I_e$	Rating at operational voltage $U_e$					Operational current $I_e$	Rating at operational voltage $U_e$				Article No.	Price per PU			
	230 V	400 V	500 V	690 V	1000 V		200 V	230 V	460 V	575 V					
A	kW	kW	kW	kW	kW	A	hp	hp	hp	hp					
<b>Inline circuit, rated operational voltage 400 ... 690 V</b>															
29	--	15	18.5	<b>30</b>	--	26	--	--	15	<b>20</b>	B	<b>3RW4422-□BC□6</b>	1	1 unit	42H
36	--	18.5	22	<b>37</b>	--	32	--	--	20	<b>25</b>	B	<b>3RW4423-□BC□6</b>	1	1 unit	42H
47	--	22	30	<b>45</b>	--	42	--	--	25	<b>30</b>	B	<b>3RW4424-□BC□6</b>	1	1 unit	42H
57	--	30	37	<b>55</b>	--	51	--	--	30	<b>40</b>	B	<b>3RW4425-□BC□6</b>	1	1 unit	42H
77	--	37	45	<b>75</b>	--	68	--	--	50	<b>50</b>	B	<b>3RW4427-□BC□6</b>	1	1 unit	42H
<b>Article No. supplement for connection types</b>															
<ul style="list-style-type: none"> <li>• With screw terminals</li> <li>• With spring-type terminals</li> </ul>															
93	--	45	55	<b>90</b>	--	82	--	--	60	<b>75</b>	B	<b>3RW4434-□BC□6</b>	1	1 unit	42H
113	--	55	75	<b>110</b>	--	100	--	--	75	<b>75</b>	B	<b>3RW4435-□BC□6</b>	1	1 unit	42H
134	--	75	90	<b>132</b>	--	117	--	--	75	<b>100</b>	B	<b>3RW4436-□BC□6</b>	1	1 unit	42H
162	--	90	110	<b>160</b>	--	145	--	--	100	<b>125</b>	B	<b>3RW4443-□BC□6</b>	1	1 unit	42H
203	--	110	132	<b>200</b>	--	180	--	--	125	<b>150</b>	B	<b>3RW4445-□BC□6</b>	1	1 unit	42H
250	--	132	160	<b>250</b>	--	215	--	--	150	<b>200</b>	B	<b>3RW4446-□BC□6</b>	1	1 unit	42H
313	--	160	200	<b>315</b>	--	280	--	--	200	<b>250</b>	B	<b>3RW4447-□BC□6</b>	1	1 unit	42H
356	--	200	250	<b>355</b>	--	315	--	--	250	<b>300</b>	B	<b>3RW4447-□BC□6</b>	1	1 unit	42H
432	--	250	315	<b>400</b>	--	385	--	--	300	<b>400</b>	C	<b>3RW4453-□BC□6</b>	1	1 unit	42H
551	--	315	355	<b>560</b>	--	494	--	--	400	<b>500</b>	C	<b>3RW4453-□BC□6</b>	1	1 unit	42H
615	--	355	400	<b>630</b>	--	551	--	--	450	<b>600</b>	C	<b>3RW4455-□BC□6</b>	1	1 unit	42H
693	--	400	500	<b>710</b>	--	615	--	--	500	<b>700</b>	C	<b>3RW4457-□BC□6</b>	1	1 unit	42H
780	--	450	560	<b>800</b>	--	693	--	--	600	<b>750</b>	C	<b>3RW4465-□BC□6</b>	1	1 unit	42H
880	--	500	630	<b>900</b>	--	780	--	--	700	<b>850</b>	C	<b>3RW4465-□BC□6</b>	1	1 unit	42H
970	--	560	710	<b>1000</b>	--	850	--	--	750	<b>900</b>	C	<b>3RW4465-□BC□6</b>	1	1 unit	42H

**Article No. supplement for connection types**

- With spring-type terminals
- With screw terminals

**Article No. supplement for rated control supply voltage  $U_s$ <sup>1)</sup>**

- 115 V AC
- 230 V AC

Online configurator see [www.siemens.com/sirius/configurators](http://www.siemens.com/sirius/configurators)

<sup>1)</sup> Control by way of the internal 24 V DC supply and direct control via PLC possible.

**Note:**

The listed motor ratings are rough guide values. The soft starter should always be designed on the basis of the required rated operational current of the motor.

The solid-state SIRIUS 3RW44 soft starters are designed for easy starting conditions. The selection and ordering data were determined for the following boundary conditions (see also the notes on page 6/6):

- Maximum starting time in s: 40
- Maximum starting current in % of motor current  $I_e$ : 350
- Maximum number of starts per hour in 1/h: 1

In case of additional requirements, it may be necessary to choose a larger device. In some cases, however, the safety margins taken into account in the selection also permit the listed units to be used in boundary conditions which are slightly more demanding. Detailed technical information for a configuration which is tailored exactly to the application, see manual <http://support.automation.siemens.com/WW/view/en/21772518>

# SIRIUS 3RW Soft Starters

## 3RW44 for High-Feature Applications

### 3RW44

**SIRIUS 3RW44 for very heavy starting (CLASS 30) in inline circuit**



3RW442.      3RW443.      3RW444.      3RW445.      3RW446.

3RW ambient temperature 40 °C						3RW ambient temperature 50 °C				DT <sup>1)</sup>	Very heavy starting (CLASS 30) in inline circuit	Configurator	Article No.	Price per PU	PU (UNIT, SET, M)	PS*	PG
Rated values of three-phase motors						Rated values of three-phase motors											
Operat. current I <sub>e</sub>	Rating at operational voltage U <sub>e</sub>					Operat. current I <sub>e</sub>	Rating at operational voltage U <sub>e</sub>										
A	230 V	400 V	500 V	690 V	1000 V	A	200 V	230 V	460 V	575 V							
	kW	kW	kW	kW	kW		hp	hp	hp	hp							

Inline circuit, rated operational voltage 200 ... 460 V															
29	5.5	<b>15</b>	--	--	--	26	7.5	7.5	<b>15</b>	--	B	3RW4422-□BC□4	1	1 unit	42H
36	7.5	<b>18.5</b>	--	--	--	32	10	10	<b>20</b>	--	B	3RW4424-□BC□4	1	1 unit	42H
47	11	<b>22</b>	--	--	--	42	10	15	<b>25</b>	--	B	3RW4425-□BC□4	1	1 unit	42H
57	15	<b>30</b>	--	--	--	51	15	15	<b>30</b>	--	B	3RW4425-□BC□4	1	1 unit	42H

**Article No. supplement for connection types**

- With screw terminals
- With spring-type terminals

77	18.5	<b>37</b>	--	--	--	68	20	20	<b>50</b>	--	B	3RW4434-□BC□4	1	1 unit	42H
93	22	<b>45</b>	--	--	--	82	25	25	<b>60</b>	--	B	3RW4435-□BC□4	1	1 unit	42H
113	30	<b>55</b>	--	--	--	100	30	30	<b>75</b>	--	B	3RW4443-□BC□4	1	1 unit	42H
134	37	<b>75</b>	--	--	--	117	30	40	<b>75</b>	--	B	3RW4443-□BC□4	1	1 unit	42H
162	45	<b>90</b>	--	--	--	145	40	50	<b>100</b>	--	B	3RW4443-□BC□4	1	1 unit	42H
203	55	<b>110</b>	--	--	--	180	50	60	<b>125</b>	--	B	3RW4446-□BC□4	1	1 unit	42H
250	75	<b>132</b>	--	--	--	215	60	75	<b>150</b>	--	B	3RW4447-□BC□4	1	1 unit	42H
313	90	<b>160</b>	--	--	--	280	75	100	<b>200</b>	--	C	3RW4453-□BC□4	1	1 unit	42H
356	110	<b>200</b>	--	--	--	315	100	125	<b>250</b>	--	C	3RW4453-□BC□4	1	1 unit	42H
432	132	<b>250</b>	--	--	--	385	125	150	<b>300</b>	--	C	3RW4453-□BC□4	1	1 unit	42H
551	160	<b>315</b>	--	--	--	494	150	200	<b>400</b>	--	C	3RW4455-□BC□4	1	1 unit	42H
615	200	<b>355</b>	--	--	--	551	150	200	<b>450</b>	--	C	3RW4458-□BC□4	1	1 unit	42H
693	200	<b>400</b>	--	--	--	615	200	250	<b>500</b>	--	C	3RW4465-□BC□4	1	1 unit	42H
780	250	<b>450</b>	--	--	--	693	200	250	<b>600</b>	--	C	3RW4465-□BC□4	1	1 unit	42H
880	250	<b>500</b>	--	--	--	780	250	300	<b>700</b>	--	C	3RW4465-□BC□4	1	1 unit	42H
970	315	<b>560</b>	--	--	--	850	300	350	<b>750</b>	--	C	3RW4466-□BC□4	1	1 unit	42H

**Article No. supplement for connection types**

- With spring-type terminals
- With screw terminals

**Article No. supplement for rated control supply voltage U<sub>s</sub><sup>2)</sup>**

- 115 V AC
- 230 V AC

Online configurator see [www.siemens.com/sirius/configurators](http://www.siemens.com/sirius/configurators)

<sup>1)</sup> 3RW442. to 3RW444. soft starters with screw terminals: delivery time class ▶ (preferred type).  
<sup>2)</sup> Control by way of the internal 24 V DC supply and direct control via PLC possible.

**Note:**

The listed motor ratings are rough guide values. The soft starter should always be designed on the basis of the required rated operational current of the motor.

The solid-state SIRIUS 3RW44 soft starters are designed for easy starting conditions. The selection and ordering data were determined for the following boundary conditions (see also the notes on page 6/6):

- Maximum starting time in s: 60
- Maximum starting current in % of motor current I<sub>e</sub>: 350
- Maximum number of starts per hour in 1/h: 1

In case of additional requirements, it may be necessary to choose a larger device. In some cases, however, the safety margins taken into account in the selection also permit the listed units to be used in boundary conditions which are slightly more demanding. Detailed technical information for a configuration which is tailored exactly to the application, see manual <http://support.automation.siemens.com/WW/view/en/21772518>



# SIRIUS 3RW Soft Starters

## 3RW44 for High-Feature Applications

3RW44

3RW ambient temperature 40 °C						3RW ambient temperature 50 °C				DT <sup>1)</sup>	Very heavy starting (CLASS 30) in inline circuit	Configurator 	PU (UNIT, SET, M)	PS*	PG	
Rated values of three-phase motors						Rated values of three-phase motors				Article No.						Price per PU
Operational current $I_e$	Rating at operational voltage $U_e$					Operational current $I_e$	Rating at operational voltage $U_e$				A	B	C			
	230 V	400 V	500 V	690 V	1000 V		200 V	230 V	460 V	575 V						hp
A	kW	kW	kW	kW	kW	A	hp	hp	hp	hp						
<b>Inline circuit, rated operational voltage 400 ... 600 V</b>																
29	--	15	<b>18.5</b>	--	--	26	--	--	15	<b>20</b>	B	<b>3RW4422-□BC□5</b>	1	1 unit	42H	
36	--	18.5	<b>22</b>	--	--	32	--	--	20	<b>25</b>	B	<b>3RW4424-□BC□5</b>	1	1 unit	42H	
47	--	22	<b>30</b>	--	--	42	--	--	25	<b>30</b>	B	<b>3RW4425-□BC□5</b>	1	1 unit	42H	
57	--	30	<b>37</b>	--	--	51	--	--	30	<b>40</b>	B	<b>3RW4425-□BC□5</b>	1	1 unit	42H	
<b>Article No. supplement for connection types</b>																
<ul style="list-style-type: none"> <li>• With screw terminals</li> <li>• With spring-type terminals</li> </ul>																
77	--	37	<b>45</b>	--	--	68	--	--	50	<b>50</b>	B	<b>3RW4434-□BC□5</b>	1	1 unit	42H	
93	--	45	<b>55</b>	--	--	82	--	--	60	<b>75</b>	B	<b>3RW4435-□BC□5</b>	1	1 unit	42H	
113	--	55	<b>75</b>	--	--	100	--	--	75	<b>75</b>	B	<b>3RW4443-□BC□5</b>	1	1 unit	42H	
134	--	75	<b>90</b>	--	--	117	--	--	75	<b>100</b>	B	<b>3RW4443-□BC□5</b>	1	1 unit	42H	
162	--	90	<b>110</b>	--	--	145	--	--	100	<b>125</b>	B	<b>3RW4443-□BC□5</b>	1	1 unit	42H	
203	--	110	<b>132</b>	--	--	180	--	--	125	<b>150</b>	B	<b>3RW4446-□BC□5</b>	1	1 unit	42H	
250	--	132	<b>160</b>	--	--	215	--	--	150	<b>200</b>	B	<b>3RW4447-□BC□5</b>	1	1 unit	42H	
313	--	160	<b>200</b>	--	--	280	--	--	200	<b>250</b>	C	<b>3RW4453-□BC□5</b>	1	1 unit	42H	
356	--	200	<b>250</b>	--	--	315	--	--	250	<b>300</b>	C	<b>3RW4453-□BC□5</b>	1	1 unit	42H	
432	--	250	<b>315</b>	--	--	385	--	--	300	<b>400</b>	C	<b>3RW4453-□BC□5</b>	1	1 unit	42H	
551	--	315	<b>355</b>	--	--	494	--	--	400	<b>500</b>	C	<b>3RW4455-□BC□5</b>	1	1 unit	42H	
615	--	355	<b>400</b>	--	--	551	--	--	450	<b>600</b>	C	<b>3RW4458-□BC□5</b>	1	1 unit	42H	
693	--	400	<b>500</b>	--	--	615	--	--	500	<b>700</b>	C	<b>3RW4465-□BC□5</b>	1	1 unit	42H	
780	--	450	<b>560</b>	--	--	693	--	--	600	<b>750</b>	C	<b>3RW4465-□BC□5</b>	1	1 unit	42H	
880	--	500	<b>630</b>	--	--	780	--	--	700	<b>850</b>	C	<b>3RW4465-□BC□5</b>	1	1 unit	42H	
--	--	--	--	--	--	850	--	--	750	<b>900</b>	C	<b>3RW4466-□BC□5</b>	1	1 unit	42H	

**Article No. supplement for connection types**

- With spring-type terminals
- With screw terminals

**Article No. supplement for rated control supply voltage  $U_s$ <sup>2)</sup>**

- 115 V AC
- 230 V AC

 Online configurator see [www.siemens.com/sirius/configurators](http://www.siemens.com/sirius/configurators)

<sup>1)</sup> Soft starter with screw terminals:  
3RW442. to 3RW444. Delivery time class A,  
3RW445. to 3RW446. Delivery time class B.

<sup>2)</sup> Control by way of the internal 24 V DC supply and direct control via PLC possible.

**Note:**

The listed motor ratings are rough guide values. The soft starter should always be designed on the basis of the required rated operational current of the motor.

The solid-state SIRIUS 3RW44 soft starters are designed for easy starting conditions. The selection and ordering data were determined for the following boundary conditions (see also the notes on page 6/6):

- Maximum starting time in s: 60
- Maximum starting current in % of motor current  $I_e$ : 350
- Maximum number of starts per hour in 1/h: 1

In case of additional requirements, it may be necessary to choose a larger device. In some cases, however, the safety margins taken into account in the selection also permit the listed units to be used in boundary conditions which are slightly more demanding. Detailed technical information for a configuration which is tailored exactly to the application, see manual <http://support.automation.siemens.com/WWW/view/en/21772518>

# SIRIUS 3RW Soft Starters

## 3RW44 for High-Feature Applications

### 3RW44

3RW ambient temperature 40 °C						3RW ambient temperature 50 °C				DT	Very heavy starting (CLASS 30) in inline circuit	Configurator 	PU (UNIT, SET, M)	PS*	PG
Rated values of three-phase motors						Rated values of three-phase motors									
Operational current $I_e$	Rating at operational voltage $U_e$					Operational current $I_e$	Rating at operational voltage $U_e$				Article No.	Price per PU			
	230 V	400 V	500 V	690 V	1000 V		200 V	230 V	460 V	575 V					
A	kW	kW	kW	kW	kW	A	hp	hp	hp	hp					
<b>Inline circuit, rated operational voltage 400 ... 690 V</b>															
29	--	15	18.5	<b>30</b>	--	26	--	--	15	<b>20</b>	B	<b>3RW4422-□BC□6</b>	1	1 unit	42H
36	--	18.5	22	<b>37</b>	--	32	--	--	20	<b>25</b>	B	<b>3RW4424-□BC□6</b>	1	1 unit	42H
47	--	22	30	<b>45</b>	--	42	--	--	25	<b>30</b>	B	<b>3RW4425-□BC□6</b>	1	1 unit	42H
57	--	30	37	<b>55</b>	--	51	--	--	30	<b>40</b>	B	<b>3RW4425-□BC□6</b>	1	1 unit	42H
<b>Article No. supplement for connection types</b>															
<ul style="list-style-type: none"> <li>• With screw terminals</li> <li>• With spring-type terminals</li> </ul>															
77	--	37	45	<b>75</b>	--	68	--	--	50	<b>50</b>	B	<b>3RW4434-□BC□6</b>	1	1 unit	42H
93	--	45	55	<b>90</b>	--	82	--	--	60	<b>75</b>	B	<b>3RW4435-□BC□6</b>	1	1 unit	42H
113	--	55	75	<b>110</b>	--	100	--	--	75	<b>75</b>	B	<b>3RW4443-□BC□6</b>	1	1 unit	42H
134	--	75	90	<b>132</b>	--	117	--	--	75	<b>100</b>	B	<b>3RW4443-□BC□6</b>	1	1 unit	42H
162	--	90	110	<b>160</b>	--	145	--	--	100	<b>125</b>	B	<b>3RW4443-□BC□6</b>	1	1 unit	42H
203	--	110	132	<b>200</b>	--	180	--	--	125	<b>150</b>	B	<b>3RW4446-□BC□6</b>	1	1 unit	42H
250	--	132	160	<b>250</b>	--	215	--	--	150	<b>200</b>	B	<b>3RW4447-□BC□6</b>	1	1 unit	42H
313	--	160	200	<b>315</b>	--	280	--	--	200	<b>250</b>	C	<b>3RW4453-□BC□6</b>	1	1 unit	42H
356	--	200	250	<b>355</b>	--	315	--	--	250	<b>300</b>	C	<b>3RW4453-□BC□6</b>	1	1 unit	42H
432	--	250	315	<b>400</b>	--	385	--	--	300	<b>400</b>	C	<b>3RW4453-□BC□6</b>	1	1 unit	42H
551	--	315	355	<b>560</b>	--	494	--	--	400	<b>500</b>	C	<b>3RW4455-□BC□6</b>	1	1 unit	42H
615	--	355	400	<b>630</b>	--	551	--	--	450	<b>600</b>	C	<b>3RW4458-□BC□6</b>	1	1 unit	42H
693	--	400	500	<b>710</b>	--	615	--	--	500	<b>700</b>	C	<b>3RW4465-□BC□6</b>	1	1 unit	42H
780	--	450	560	<b>800</b>	--	693	--	--	600	<b>750</b>	C	<b>3RW4465-□BC□6</b>	1	1 unit	42H
880	--	500	630	<b>900</b>	--	780	--	--	700	<b>850</b>	C	<b>3RW4465-□BC□6</b>	1	1 unit	42H
--	--	--	--	--	--	850	--	--	750	<b>900</b>	C	<b>3RW4466-□BC□6</b>	1	1 unit	42H

#### Article No. supplement for connection types

- With spring-type terminals
- With screw terminals

#### Article No. supplement for rated control supply voltage $U_s$ <sup>1)</sup>

- 115 V AC
- 230 V AC

 Online configurator see [www.siemens.com/sirius/configurators](http://www.siemens.com/sirius/configurators)

<sup>1)</sup> Control by way of the internal 24 V DC supply and direct control via PLC possible.

#### Note:

The listed motor ratings are rough guide values. The soft starter should always be designed on the basis of the required rated operational current of the motor.

The solid-state SIRIUS 3RW44 soft starters are designed for easy starting conditions. The selection and ordering data were determined for the following boundary conditions (see also the notes on page 6/6):

- Maximum starting time in s: 60
- Maximum starting current in % of motor current  $I_e$ : 350
- Maximum number of starts per hour in 1/h: 1

In case of additional requirements, it may be necessary to choose a larger device. In some cases, however, the safety margins taken into account in the selection also permit the listed units to be used in boundary conditions which are slightly more demanding. Detailed technical information for a configuration which is tailored exactly to the application, see manual <http://support.automation.siemens.com/WW/view/en/21772518>



# SIRIUS 3RW Soft Starters

## 3RW44 for High-Feature Applications

3RW44

### SIRIUS 3RW44 for normal starting (CLASS 10) in inside-delta circuit



3RW ambient temperature 40 °C						3RW ambient temperature 50 °C						DT <sup>1)</sup> Normal starting (CLASS 10) in inside-delta circuit		PU (UNIT, SET, M)	PS*	PG	
Rated values of three-phase motors						Rated values of three-phase motors						Configurator					
Operational current I <sub>e</sub>	Rating at operational voltage U <sub>e</sub>					Operational current I <sub>e</sub>	Rating at operational voltage U <sub>e</sub>					Article No.	Price per PU				
	230 V	400 V	500 V	690 V	1000 V		200 V	230 V	460 V	575 V							
A	kW	kW	kW	kW	kW	A	hp	hp	hp	hp							
<b>Inside-delta circuit, rated operational voltage 200 ... 460 V</b>																	
50	15	<b>22</b>	--	--	--	45	10	15	<b>30</b>	--	B	<b>3RW4422-□BC□4</b>		1	1 unit	42H	
62	18.5	<b>30</b>	--	--	--	55	15	20	<b>40</b>	--	B	<b>3RW4423-□BC□4</b>		1	1 unit	42H	
81	22	<b>45</b>	--	--	--	73	20	25	<b>50</b>	--	B	<b>3RW4424-□BC□4</b>		1	1 unit	42H	
99	30	<b>55</b>	--	--	--	88	25	30	<b>60</b>	--	B	<b>3RW4425-□BC□4</b>		1	1 unit	42H	
133	37	<b>75</b>	--	--	--	118	30	40	<b>75</b>	--	B	<b>3RW4426-□BC□4</b>		1	1 unit	42H	
161	45	<b>90</b>	--	--	--	142	40	50	<b>100</b>	--	B	<b>3RW4427-□BC□4</b>		1	1 unit	42H	
<b>Article No. supplement for connection types</b>																	
<ul style="list-style-type: none"> <li>• With screw terminals</li> <li>• With spring-type terminals</li> </ul>																	
196	55	<b>110</b>	--	--	--	173	50	60	<b>125</b>	--	B	<b>3RW4434-□BC□4</b>		1	1 unit	42H	
232	75	<b>132</b>	--	--	--	203	60	75	<b>150</b>	--	B	<b>3RW4435-□BC□4</b>		1	1 unit	42H	
281	90	<b>160</b>	--	--	--	251	75	100	<b>200</b>	--	B	<b>3RW4436-□BC□4</b>		1	1 unit	42H	
352	110	<b>200</b>	--	--	--	312	100	125	<b>250</b>	--	B	<b>3RW4443-□BC□4</b>		1	1 unit	42H	
433	132	<b>250</b>	--	--	--	372	125	150	<b>300</b>	--	B	<b>3RW4444-□BC□4</b>		1	1 unit	42H	
542	160	<b>315</b>	--	--	--	485	150	200	<b>400</b>	--	B	<b>3RW4445-□BC□4</b>		1	1 unit	42H	
617	200	<b>355</b>	--	--	--	546	150	200	<b>450</b>	--	B	<b>3RW4446-□BC□4</b>		1	1 unit	42H	
748	250	<b>400</b>	--	--	--	667	200	250	<b>600</b>	--	B	<b>3RW4447-□BC□4</b>		1	1 unit	42H	
954	315	<b>560</b>	--	--	--	856	300	350	<b>750</b>	--	C	<b>3RW4453-□BC□4</b>		1	1 unit	42H	
1065	355	<b>630</b>	--	--	--	954	350	400	<b>850</b>	--	C	<b>3RW4454-□BC□4</b>		1	1 unit	42H	
1200	400	<b>710</b>	--	--	--	1065	350	450	<b>950</b>	--	C	<b>3RW4455-□BC□4</b>		1	1 unit	42H	
1351	450	<b>800</b>	--	--	--	1200	450	500	<b>1050</b>	--	C	<b>3RW4456-□BC□4</b>		1	1 unit	42H	
1524	500	<b>900</b>	--	--	--	1351	450	600	<b>1200</b>	--	C	<b>3RW4457-□BC□4</b>		1	1 unit	42H	
1680	560	<b>1000</b>	--	--	--	1472	550	650	<b>1300</b>	--	C	<b>3RW4458-□BC□4</b>		1	1 unit	42H	
1864	630	<b>1100</b>	--	--	--	1680	650	750	<b>1500</b>	--	C	<b>3RW4465-□BC□4</b>		1	1 unit	42H	
2103	710	<b>1200</b>	--	--	--	1864	700	850	<b>1700</b>	--	C	<b>3RW4466-□BC□4</b>		1	1 unit	42H	

#### Article No. supplement for connection types

- With spring-type terminals
- With screw terminals

#### Article No. supplement for rated control supply voltage U<sub>s</sub><sup>2)</sup>

- 115 V AC
- 230 V AC

Online configurator see [www.siemens.com/sirius/configurators](http://www.siemens.com/sirius/configurators)

<sup>1)</sup> 3RW442. to 3RW444. soft starters with screw terminals: delivery time class ► (preferred type).

<sup>2)</sup> Control by way of the internal 24 V DC supply and direct control via PLC possible.

#### Note:

The listed motor ratings are rough guide values. The soft starter should always be designed on the basis of the required rated operational current of the motor.

The solid-state SIRIUS 3RW44 soft starters are designed for easy starting conditions. The selection and ordering data were determined for the following boundary conditions (see also the notes on page 6/6):

- Maximum starting time in s: 10
- Maximum starting current in % of motor current I<sub>e</sub>: 300
- Maximum number of starts per hour in 1/h: 5

In the selection table, the unit rated current I<sub>e</sub> refers to the three-phase motor's rated operational current in the inside-delta circuit. The actual current of the device is approx. 58 % of this value.

In case of additional requirements, it may be necessary to choose a larger device. In some cases, however, the safety margins taken into account in the selection also permit the listed units to be used in boundary conditions which are slightly more demanding. Detailed technical information for a configuration which is tailored exactly to the application, see manual <http://support.automation.siemens.com/WW/view/en/21772518>

# SIRIUS 3RW Soft Starters

## 3RW44 for High-Feature Applications

### 3RW44

3RW ambient temperature 40 °C					3RW ambient temperature 50 °C				DT <sup>1)</sup>	Normal starting (CLASS 10) in inside-delta circuit	PU (UNIT, SET, M)	PS*	PG		
Rated values of three-phase motors					Rated values of three-phase motors										
Operational current $I_e$	Rating at operational voltage $U_e$					Operational current $I_e$	Rating at operational voltage $U_e$				Configurator 	Article No.	Price per PU		
	230 V	400 V	500 V	690 V	1000 V		200 V	230 V	460 V	575 V					
A	kW	kW	kW	kW	kW	A	hp	hp	hp	hp					
<b>Inside-delta circuit, rated operational voltage 400 ... 600 V</b>															
50	--	22	<b>30</b>	--	--	45	--	--	30	<b>40</b>	B	<b>3RW4422-□BC□5</b>	1	1 unit	42H
62	--	30	<b>37</b>	--	--	55	--	--	40	<b>50</b>	B	<b>3RW4423-□BC□5</b>	1	1 unit	42H
81	--	45	<b>45</b>	--	--	73	--	--	50	<b>60</b>	B	<b>3RW4424-□BC□5</b>	1	1 unit	42H
99	--	55	<b>55</b>	--	--	88	--	--	60	<b>75</b>	B	<b>3RW4425-□BC□5</b>	1	1 unit	42H
133	--	75	<b>90</b>	--	--	118	--	--	75	<b>100</b>	B	<b>3RW4426-□BC□5</b>	1	1 unit	42H
161	--	90	<b>110</b>	--	--	142	--	--	100	<b>125</b>	B	<b>3RW4427-□BC□5</b>	1	1 unit	42H
<b>Article No. supplement for connection types</b>															
<ul style="list-style-type: none"> <li>• With screw terminals</li> <li>• With spring-type terminals</li> </ul>															
196	--	110	<b>132</b>	--	--	173	--	--	125	<b>150</b>	B	<b>3RW4434-□BC□5</b>	1	1 unit	42H
232	--	132	<b>160</b>	--	--	203	--	--	150	<b>200</b>	B	<b>3RW4435-□BC□5</b>	1	1 unit	42H
281	--	160	<b>200</b>	--	--	251	--	--	200	<b>250</b>	B	<b>3RW4436-□BC□5</b>	1	1 unit	42H
352	--	200	<b>250</b>	--	--	312	--	--	250	<b>300</b>	B	<b>3RW4443-□BC□5</b>	1	1 unit	42H
433	--	250	<b>315</b>	--	--	372	--	--	300	<b>350</b>	B	<b>3RW4444-□BC□5</b>	1	1 unit	42H
542	--	315	<b>355</b>	--	--	485	--	--	400	<b>500</b>	B	<b>3RW4445-□BC□5</b>	1	1 unit	42H
617	--	355	<b>450</b>	--	--	546	--	--	450	<b>600</b>	B	<b>3RW4446-□BC□5</b>	1	1 unit	42H
748	--	400	<b>500</b>	--	--	667	--	--	600	<b>750</b>	B	<b>3RW4447-□BC□5</b>	1	1 unit	42H
954	--	560	<b>630</b>	--	--	856	--	--	750	<b>950</b>	C	<b>3RW4453-□BC□5</b>	1	1 unit	42H
1065	--	630	<b>710</b>	--	--	954	--	--	850	<b>1050</b>	C	<b>3RW4454-□BC□5</b>	1	1 unit	42H
1200	--	710	<b>800</b>	--	--	1065	--	--	950	<b>1200</b>	C	<b>3RW4455-□BC□5</b>	1	1 unit	42H
1351	--	800	<b>900</b>	--	--	1200	--	--	1050	<b>1350</b>	C	<b>3RW4456-□BC□5</b>	1	1 unit	42H
1524	--	900	<b>1000</b>	--	--	1351	--	--	1200	<b>1500</b>	C	<b>3RW4457-□BC□5</b>	1	1 unit	42H
1680	--	1000	<b>1200</b>	--	--	1472	--	--	1300	<b>1650</b>	C	<b>3RW4458-□BC□5</b>	1	1 unit	42H
1864	--	1100	<b>1350</b>	--	--	1680	--	--	1500	<b>1900</b>	C	<b>3RW4465-□BC□5</b>	1	1 unit	42H
2103	--	1200	<b>1500</b>	--	--	1864	--	--	1700	<b>2100</b>	C	<b>3RW4466-□BC□5</b>	1	1 unit	42H

#### Article No. supplement for connection types

- With spring-type terminals
- With screw terminals

#### Article No. supplement for rated control supply voltage $U_s$ <sup>2)</sup>

- 115 V AC
- 230 V AC

 Online configurator see [www.siemens.com/sirius/configurators](http://www.siemens.com/sirius/configurators)

- Soft starter with screw terminals:  
3RW442. to 3RW444. Delivery time class A,  
3RW445. to 3RW446. Delivery time class B.
- Control by way of the internal 24 V DC supply and direct control via PLC possible.

#### Note:

The listed motor ratings are rough guide values. The soft starter should always be designed on the basis of the required rated operational current of the motor.

The solid-state SIRIUS 3RW44 soft starters are designed for easy starting conditions. The selection and ordering data were determined for the following boundary conditions (see also the notes on page 6/6):

- Maximum starting time in s: 10
- Maximum starting current in % of motor current  $I_e$ : 300
- Maximum number of starts per hour in 1/h: 5

In the selection table, the unit rated current  $I_e$  refers to the three-phase motor's rated operational current in the inside-delta circuit. The actual current of the device is approx. 58 % of this value.

In case of additional requirements, it may be necessary to choose a larger device. In some cases, however, the safety margins taken into account in the selection also permit the listed units to be used in boundary conditions which are slightly more demanding. Detailed technical information for a configuration which is tailored exactly to the application, see manual <http://support.automation.siemens.com/WW/view/en/21772518>

# SIRIUS 3RW Soft Starters

## 3RW44 for High-Feature Applications

3RW44

### SIRIUS 3RW44 for heavy starting (CLASS 20) in inside-delta circuit



3RW442.      3RW443.      3RW444.      3RW445.      3RW446.

3RW ambient temperature 40 °C						3RW ambient temperature 50 °C				DT <sup>1)</sup>	Heavy starting (CLASS 20) in inside-delta circuit	PU (UNIT, SET, M)	PS*	PG
Rated values of three-phase motors						Rated values of three-phase motors					Configurator			
Operat. current I <sub>e</sub>	Rating at operational voltage U <sub>e</sub>					Operat. current I <sub>e</sub>	Rating at operational voltage U <sub>e</sub>				Article No.	Price per PU		
	230 V	400 V	500 V	690 V	1000 V		200 V	230 V	460 V	575 V				
A	kW	kW	kW	kW	kW	A	hp	hp	hp	hp				

Inside-delta circuit, rated operational voltage 200 ... 460 V															
50	15	<b>22</b>	--	--	--	45	10	15	<b>30</b>	--	B	<b>3RW4423-□BC□4</b>	1	1 unit	42H
62	18.5	<b>30</b>	--	--	--	55	15	20	<b>40</b>	--	B	<b>3RW4424-□BC□4</b>	1	1 unit	42H
81	22	<b>45</b>	--	--	--	73	20	25	<b>50</b>	--	B	<b>3RW4425-□BC□4</b>	1	1 unit	42H
99	30	<b>55</b>	--	--	--	88	25	30	<b>60</b>	--	B	<b>3RW4425-□BC□4</b>	1	1 unit	42H
133	37	<b>75</b>	--	--	--	118	30	40	<b>75</b>	--	B	<b>3RW4427-□BC□4</b>	1	1 unit	42H

#### Article No. supplement for connection types

- With screw terminals
- With spring-type terminals

161	45	<b>90</b>	--	--	--	142	40	50	<b>100</b>	--	B	<b>3RW4434-□BC□4</b>	1	1 unit	42H
196	55	<b>110</b>	--	--	--	173	50	60	<b>125</b>	--	B	<b>3RW4435-□BC□4</b>	1	1 unit	42H
232	75	<b>132</b>	--	--	--	203	60	75	<b>150</b>	--	B	<b>3RW4436-□BC□4</b>	1	1 unit	42H
281	90	<b>160</b>	--	--	--	251	75	100	<b>200</b>	--	B	<b>3RW4443-□BC□4</b>	1	1 unit	42H
352	110	<b>200</b>	--	--	--	312	100	125	<b>250</b>	--	B	<b>3RW4444-□BC□4</b>	1	1 unit	42H
433	132	<b>250</b>	--	--	--	372	125	150	<b>300</b>	--	B	<b>3RW4445-□BC□4</b>	1	1 unit	42H
542	160	<b>315</b>	--	--	--	485	150	200	<b>400</b>	--	B	<b>3RW4447-□BC□4</b>	1	1 unit	42H
617	200	<b>355</b>	--	--	--	546	150	200	<b>450</b>	--	B	<b>3RW4447-□BC□4</b>	1	1 unit	42H
748	250	<b>400</b>	--	--	--	667	200	250	<b>600</b>	--	C	<b>3RW4453-□BC□4</b>	1	1 unit	42H
954	315	<b>560</b>	--	--	--	856	300	350	<b>750</b>	--	C	<b>3RW4453-□BC□4</b>	1	1 unit	42H
1065	355	<b>630</b>	--	--	--	954	350	400	<b>850</b>	--	C	<b>3RW4455-□BC□4</b>	1	1 unit	42H
1200	400	<b>710</b>	--	--	--	1065	350	450	<b>950</b>	--	C	<b>3RW4457-□BC□4</b>	1	1 unit	42H
1351	450	<b>800</b>	--	--	--	1200	450	500	<b>1050</b>	--	C	<b>3RW4465-□BC□4</b>	1	1 unit	42H
1524	500	<b>900</b>	--	--	--	1351	450	600	<b>1200</b>	--	C	<b>3RW4465-□BC□4</b>	1	1 unit	42H
1680	560	<b>1000</b>	--	--	--	1472	550	650	<b>1300</b>	--	C	<b>3RW4465-□BC□4</b>	1	1 unit	42H
--	--	--	--	--	--	1680	650	750	<b>1500</b>	--	C	<b>3RW4466-□BC□4</b>	1	1 unit	42H

#### Article No. supplement for connection types

- With spring-type terminals
- With screw terminals

#### Article No. supplement for rated control supply voltage U<sub>s</sub><sup>2)</sup>

- 115 V AC
- 230 V AC

Online configurator see [www.siemens.com/sirius/configurators](http://www.siemens.com/sirius/configurators)

<sup>1)</sup> 3RW442. to 3RW444. soft starters with screw terminals: delivery time class ▶ (preferred type).

<sup>2)</sup> Control by way of the internal 24 V DC supply and direct control via PLC possible.

#### Note:

The listed motor ratings are rough guide values. The soft starter should always be designed on the basis of the required rated operational current of the motor.

The solid-state SIRIUS 3RW44 soft starters are designed for easy starting conditions. The selection and ordering data were determined for the following boundary conditions (see also the notes on page 6/6):

- Maximum starting time in s: 40
- Maximum starting current in % of motor current I<sub>e</sub>: 350
- Maximum number of starts per hour in 1/h: 1

In the selection table, the unit rated current I<sub>e</sub> refers to the three-phase motor's rated operational current in the inside-delta circuit. The actual current of the device is approx. 58 % of this value.

In case of additional requirements, it may be necessary to choose a larger device. In some cases, however, the safety margins taken into account in the selection also permit the listed units to be used in boundary conditions which are slightly more demanding. Detailed technical information for a configuration which is tailored exactly to the application see manual.

# SIRIUS 3RW Soft Starters

## 3RW44 for High-Feature Applications

### 3RW44

3RW ambient temperature 40 °C					3RW ambient temperature 50 °C				DT <sup>1)</sup>	Heavy starting (CLASS 20) in inside-delta circuit	PU (UNIT, SET, M)	PS*	PG		
Rated values of three-phase motors					Rated values of three-phase motors				Configurator 						
Operational current $I_e$	Rating at operational voltage $U_e$					Operational current $I_e$	Rating at operational voltage $U_e$				Article No.	Price per PU			
	230 V	400 V	500 V	690 V	1000 V		200 V	230 V	460 V	575 V					
A	kW	kW	kW	kW	kW	A	hp	hp	hp	hp					
<b>Inside-delta circuit, rated operational voltage 400 ... 600 V</b>															
50	--	22	<b>30</b>	--	--	45	--	--	30	<b>40</b>	B	<b>3RW4423-□BC□5</b>	1	1 unit	42H
62	--	30	<b>37</b>	--	--	55	--	--	40	<b>50</b>	B	<b>3RW4424-□BC□5</b>	1	1 unit	42H
81	--	45	<b>45</b>	--	--	73	--	--	50	<b>60</b>	B	<b>3RW4425-□BC□5</b>	1	1 unit	42H
99	--	55	<b>55</b>	--	--	88	--	--	60	<b>75</b>	B	<b>3RW4425-□BC□5</b>	1	1 unit	42H
133	--	75	<b>90</b>	--	--	118	--	--	75	<b>100</b>	B	<b>3RW4427-□BC□5</b>	1	1 unit	42H
<b>Article No. supplement for connection types</b>															
<ul style="list-style-type: none"> <li>• With screw terminals</li> <li>• With spring-type terminals</li> </ul>															
161	--	90	<b>110</b>	--	--	142	--	--	100	<b>125</b>	B	<b>3RW4434-□BC□5</b>	1	1 unit	42H
196	--	110	<b>132</b>	--	--	173	--	--	125	<b>150</b>	B	<b>3RW4435-□BC□5</b>	1	1 unit	42H
232	--	132	<b>160</b>	--	--	203	--	--	150	<b>200</b>	B	<b>3RW4436-□BC□5</b>	1	1 unit	42H
281	--	160	<b>200</b>	--	--	251	--	--	200	<b>250</b>	B	<b>3RW4443-□BC□5</b>	1	1 unit	42H
352	--	200	<b>250</b>	--	--	312	--	--	250	<b>300</b>	B	<b>3RW4444-□BC□5</b>	1	1 unit	42H
433	--	250	<b>315</b>	--	--	372	--	--	300	<b>350</b>	B	<b>3RW4445-□BC□5</b>	1	1 unit	42H
542	--	315	<b>355</b>	--	--	485	--	--	400	<b>500</b>	B	<b>3RW4447-□BC□5</b>	1	1 unit	42H
617	--	355	<b>450</b>	--	--	546	--	--	450	<b>600</b>	B	<b>3RW4447-□BC□5</b>	1	1 unit	42H
748	--	400	<b>500</b>	--	--	667	--	--	600	<b>750</b>	C	<b>3RW4453-□BC□5</b>	1	1 unit	42H
954	--	560	<b>630</b>	--	--	856	--	--	750	<b>950</b>	C	<b>3RW4453-□BC□5</b>	1	1 unit	42H
1065	--	630	<b>710</b>	--	--	954	--	--	850	<b>1050</b>	C	<b>3RW4455-□BC□5</b>	1	1 unit	42H
1200	--	710	<b>800</b>	--	--	1065	--	--	950	<b>1200</b>	C	<b>3RW4457-□BC□5</b>	1	1 unit	42H
1351	--	800	<b>900</b>	--	--	1200	--	--	1050	<b>1350</b>	C	<b>3RW4465-□BC□5</b>	1	1 unit	42H
1524	--	900	<b>1000</b>	--	--	1351	--	--	1200	<b>1500</b>	C	<b>3RW4465-□BC□5</b>	1	1 unit	42H
1680	--	1000	<b>1200</b>	--	--	1472	--	--	1300	<b>1650</b>	C	<b>3RW4465-□BC□5</b>	1	1 unit	42H
--	--	--	--	--	--	1680	--	--	1500	<b>1900</b>	C	<b>3RW4466-□BC□5</b>	1	1 unit	42H

#### Article No. supplement for connection types

- With spring-type terminals
- With screw terminals

#### Article No. supplement for rated control supply voltage $U_s$ <sup>2)</sup>

- 115 V AC
- 230 V AC

 Online configurator see [www.siemens.com/sirius/configurators](http://www.siemens.com/sirius/configurators)

<sup>1)</sup> Soft starter with screw terminals:  
3RW442. to 3RW444. Delivery time class A,  
3RW445. to 3RW446. Delivery time class B.

<sup>2)</sup> Control by way of the internal 24 V DC supply and direct control via PLC possible.

#### Note:

The listed motor ratings are rough guide values. The soft starter should always be designed on the basis of the required rated operational current of the motor.

The solid-state SIRIUS 3RW44 soft starters are designed for easy starting conditions. The selection and ordering data were determined for the following boundary conditions (see also the notes on page 6/6):

- Maximum starting time in s: 40
- Maximum starting current in % of motor current  $I_e$ : 350
- Maximum number of starts per hour in 1/h: 1

In the selection table, the unit rated current  $I_e$  refers to the three-phase motor's rated operational current in the inside-delta circuit. The actual current of the device is approx. 58 % of this value.

In case of additional requirements, it may be necessary to choose a larger device. In some cases, however, the safety margins taken into account in the selection also permit the listed units to be used in boundary conditions which are slightly more demanding. Detailed technical information for a configuration which is tailored exactly to the application, see manual <http://support.automation.siemens.com/WW/view/en/21772518>

# SIRIUS 3RW Soft Starters

## 3RW44 for High-Feature Applications

3RW44

### SIRIUS 3RW44 for very heavy starting (CLASS 30) in inside-delta circuit



3RW ambient temperature 40 °C						3RW ambient temperature 50 °C						DT <sup>1)</sup> Very heavy starting (CLASS 30) in inside-delta circuit		PU (UNIT, SET, M)	PS*	PG
Rated values of three-phase motors						Rated values of three-phase motors						Configurator				
Operational current $I_e$		Rating at operational voltage $U_e$				Operational current $I_e$		Rating at operational voltage $U_e$				Article No.	Price per PU			
A	kW	kW	kW	kW	kW	A	hp	hp	hp	hp						
230 V						200 V										
400 V						230 V										
500 V						460 V										
690 V						575 V										
1000 V																
<b>Inside-delta circuit, rated operational voltage 200 ... 460 V</b>																
50	15	<b>22</b>	--	--	--	45	10	15	<b>30</b>	--	B	<b>3RW4423-□BC□4</b>		1	1 unit	42H
62	18.5	<b>30</b>	--	--	--	55	15	20	<b>40</b>	--	B	<b>3RW4424-□BC□4</b>		1	1 unit	42H
81	22	<b>45</b>	--	--	--	73	20	25	<b>50</b>	--	B	<b>3RW4425-□BC□4</b>		1	1 unit	42H
99	30	<b>55</b>	--	--	--	88	25	30	<b>60</b>	--	B	<b>3RW4425-□BC□4</b>		1	1 unit	42H
133	37	<b>75</b>	--	--	--	118	30	40	<b>75</b>	--	B	<b>3RW4427-□BC□4</b>		1	1 unit	42H
<b>Article No. supplement for connection types</b>																
<ul style="list-style-type: none"> <li>• With screw terminals</li> <li>• With spring-type terminals</li> </ul>																
161	45	<b>90</b>	--	--	--	142	40	50	<b>100</b>	--	B	<b>3RW4435-□BC□4</b>		1	1 unit	42H
196	55	<b>110</b>	--	--	--	173	50	60	<b>125</b>	--	B	<b>3RW4436-□BC□4</b>		1	1 unit	42H
232	75	<b>132</b>	--	--	--	203	60	75	<b>150</b>	--	B	<b>3RW4443-□BC□4</b>		1	1 unit	42H
281	90	<b>160</b>	--	--	--	251	75	100	<b>200</b>	--	B	<b>3RW4443-□BC□4</b>		1	1 unit	42H
352	110	<b>200</b>	--	--	--	312	100	125	<b>250</b>	--	B	<b>3RW4445-□BC□4</b>		1	1 unit	42H
433	132	<b>250</b>	--	--	--	372	125	150	<b>300</b>	--	B	<b>3RW4447-□BC□4</b>		1	1 unit	42H
542	160	<b>315</b>	--	--	--	485	150	200	<b>400</b>	--	C	<b>3RW4453-□BC□4</b>		1	1 unit	42H
617	200	<b>355</b>	--	--	--	546	150	200	<b>450</b>	--	C	<b>3RW4453-□BC□4</b>		1	1 unit	42H
748	250	<b>400</b>	--	--	--	667	200	250	<b>600</b>	--	C	<b>3RW4453-□BC□4</b>		1	1 unit	42H
954	315	<b>560</b>	--	--	--	856	300	350	<b>750</b>	--	C	<b>3RW4455-□BC□4</b>		1	1 unit	42H
1065	355	<b>630</b>	--	--	--	954	350	400	<b>850</b>	--	C	<b>3RW4458-□BC□4</b>		1	1 unit	42H
1200	400	<b>710</b>	--	--	--	1065	350	450	<b>950</b>	--	C	<b>3RW4465-□BC□4</b>		1	1 unit	42H
1351	450	<b>800</b>	--	--	--	1200	450	500	<b>1050</b>	--	C	<b>3RW4465-□BC□4</b>		1	1 unit	42H
1524	500	<b>900</b>	--	--	--	1351	450	600	<b>1200</b>	--	C	<b>3RW4465-□BC□4</b>		1	1 unit	42H
--	--	--	--	--	--	1472	550	650	<b>1300</b>	--	C	<b>3RW4466-□BC□4</b>		1	1 unit	42H

#### Article No. supplement for connection types

- With spring-type terminals
- With screw terminals

#### Article No. supplement for rated control supply voltage $U_s$ <sup>2)</sup>

- 115 V AC
- 230 V AC

Online configurator see [www.siemens.com/sirius/configurators](http://www.siemens.com/sirius/configurators)

<sup>1)</sup> 3RW442. to 3RW444. soft starters with screw terminals: delivery time class ► (preferred type).

<sup>2)</sup> Control by way of the internal 24 V DC supply and direct control via PLC possible.

#### Note:

The listed motor ratings are rough guide values. The soft starter should always be designed on the basis of the required rated operational current of the motor.

The solid-state SIRIUS 3RW44 soft starters are designed for easy starting conditions. The selection and ordering data were determined for the following boundary conditions (see also the notes on page 6/6):

- Maximum starting time in s: 60
- Maximum starting current in % of motor current  $I_e$ : 350
- Maximum number of starts per hour in 1/h: 1

In the selection table, the unit rated current  $I_e$  refers to the three-phase motor's rated operational current in the inside-delta circuit. The actual current of the device is approx. 58 % of this value.

In case of additional requirements, it may be necessary to choose a larger device. In some cases, however, the safety margins taken into account in the selection also permit the listed units to be used in boundary conditions which are slightly more demanding. Detailed technical information for a configuration which is tailored exactly to the application, see manual <http://support.automation.siemens.com/WW/view/en/21772518>.

# SIRIUS 3RW Soft Starters

## 3RW44 for High-Feature Applications

### 3RW44

3RW ambient temperature 40 °C					3RW ambient temperature 50 °C				DT <sup>1)</sup>	Very heavy starting (CLASS 30) in inside-delta circuit	PU (UNIT, SET, M)	PS*	PG		
Rated values of three-phase motors					Rated values of three-phase motors										
Operational current $I_e$	Rating at operational voltage $U_e$					Operational current $I_e$	Rating at operational voltage $U_e$				Configurator 				
	230 V	400 V	500 V	690 V	1000 V		200 V	230 V	460 V	575 V		Article No.	Price per PU		
A	kW	kW	kW	kW	kW	A	hp	hp	hp	hp					
<b>Inside-delta circuit, rated operational voltage 400 ... 600 V</b>															
50	--	22	<b>30</b>	--	--	45	--	--	30	<b>40</b>	B	3RW4423-□BC□5	1	1 unit	42H
62	--	30	<b>37</b>	--	--	55	--	--	40	<b>50</b>	B	3RW4424-□BC□5	1	1 unit	42H
81	--	45	<b>45</b>	--	--	73	--	--	50	<b>60</b>	B	3RW4425-□BC□5	1	1 unit	42H
99	--	55	<b>55</b>	--	--	88	--	--	60	<b>75</b>	B	3RW4425-□BC□5	1	1 unit	42H
133	--	75	<b>90</b>	--	--	118	--	--	75	<b>100</b>	B	3RW4427-□BC□5	1	1 unit	42H
<b>Article No. supplement for connection types</b>															
<ul style="list-style-type: none"> <li>• With screw terminals</li> <li>• With spring-type terminals</li> </ul>															
161	--	90	<b>110</b>	--	--	142	--	--	100	<b>125</b>	B	3RW4435-□BC□5	1	1 unit	42H
196	--	110	<b>132</b>	--	--	173	--	--	125	<b>150</b>	B	3RW4436-□BC□5	1	1 unit	42H
232	--	132	<b>160</b>	--	--	203	--	--	150	<b>200</b>	B	3RW4443-□BC□5	1	1 unit	42H
281	--	160	<b>200</b>	--	--	251	--	--	200	<b>250</b>	B	3RW4443-□BC□5	1	1 unit	42H
352	--	200	<b>250</b>	--	--	312	--	--	250	<b>300</b>	B	3RW4445-□BC□5	1	1 unit	42H
433	--	250	<b>315</b>	--	--	372	--	--	300	<b>350</b>	B	3RW4447-□BC□5	1	1 unit	42H
542	--	315	<b>355</b>	--	--	485	--	--	400	<b>500</b>	C	3RW4453-□BC□5	1	1 unit	42H
617	--	355	<b>450</b>	--	--	546	--	--	450	<b>600</b>	C	3RW4453-□BC□5	1	1 unit	42H
748	--	400	<b>500</b>	--	--	667	--	--	600	<b>750</b>	C	3RW4453-□BC□5	1	1 unit	42H
954	--	560	<b>630</b>	--	--	856	--	--	750	<b>950</b>	C	3RW4455-□BC□5	1	1 unit	42H
1 065	--	630	<b>710</b>	--	--	954	--	--	850	<b>1 050</b>	C	3RW4458-□BC□5	1	1 unit	42H
1 200	--	710	<b>800</b>	--	--	1 065	--	--	950	<b>1 200</b>	C	3RW4465-□BC□5	1	1 unit	42H
1 351	--	800	<b>900</b>	--	--	1 200	--	--	1 050	<b>1 350</b>	C	3RW4465-□BC□5	1	1 unit	42H
1 524	--	900	<b>1 000</b>	--	--	1 351	--	--	1 200	<b>1 500</b>	C	3RW4465-□BC□5	1	1 unit	42H
--	--	--	--	--	--	1 472	--	--	1 300	<b>1 650</b>	C	3RW4466-□BC□5	1	1 unit	42H

#### Article No. supplement for connection types

- With spring-type terminals
- With screw terminals

#### Article No. supplement for rated control supply voltage $U_s$ <sup>2)</sup>

- 115 V AC
- 230 V AC

 Online configurator see [www.siemens.com/sirius/configurators](http://www.siemens.com/sirius/configurators)

<sup>1)</sup> Soft starter with screw terminals:  
3RW442. to 3RW444. Delivery time class A,  
3RW445. to 3RW446. Delivery time class B.

<sup>2)</sup> Control by way of the internal 24 V DC supply and direct control via PLC possible.

#### Note:

The listed motor ratings are rough guide values. The soft starter should always be designed on the basis of the required rated operational current of the motor.

The solid-state SIRIUS 3RW44 soft starters are designed for easy starting conditions. The selection and ordering data were determined for the following boundary conditions (see also the notes on page 6/6):

- Maximum starting time in s: 60
- Maximum starting current in % of motor current  $I_e$ : 350
- Maximum number of starts per hour in 1/h: 1

In the selection table, the unit rated current  $I_e$  refers to the three-phase motor's rated operational current in the inside-delta circuit. The actual current of the device is approx. 58 % of this value.



In case of additional requirements, it may be necessary to choose a larger device. In some cases, however, the safety margins taken into account in the selection also permit the listed units to be used in boundary conditions which are slightly more demanding. Detailed technical information for a configuration which is tailored exactly to the application, see manual <http://support.automation.siemens.com/WW/view/en/21772518>

# SIRIUS 3RW Soft Starters

## 3RW44 for High-Feature Applications

3RW44

### Accessories

Version	DT	Article No.	Price per PU	PU (UNIT, SET, M)	PS*	PG
<b>Soft Starter ES 2007 PC communication program<sup>1)</sup></b>						
		<b>Soft Starter ES 2007 Basic</b> Floating license for one user E-SW, software and documentation on CD, 3 languages (German/English/French), communication through system interface • License key on USB stick, Class A, including CD	B	<b>3ZS1313-4CC10-0YA5</b>	1	1 unit 42H
		<b>Soft Starter ES 2007 Standard</b> <b>Floating license for one user</b> E-SW, software and documentation on CD, 3 languages (German/English/French), communication through system interface • License key on USB stick, Class A, including CD	B	<b>3ZS1313-5CC10-0YA5</b>	1	1 unit 42H
		<b>Soft Starter ES 2007 Premium</b> Floating license for one user E-SW, software and documentation on CD, 3 languages (German/English/French), communication through system interface or PROFIBUS/PROFINET • License key on USB stick, Class A, including CD	B	<b>3ZS1313-6CC10-0YA5</b>	1	1 unit 42H
<b>SIRIUS 3RW44 Soft Starter block library for SIMATIC PCS 7<sup>1)</sup></b>						
		Scope of supply: AS modules and faceplates for integrating SIRIUS 3RW44 into the PCS 7 process control system, for PCS 7, version V 6.1/V 7.0				
		<b>Engineering software</b> for one engineering station (single license) including runtime software for execution of the AS module in an automation system (single license), German/English/French, Type of delivery: on CD incl. electronic documentation in German/English/Portuguese	▶	<b>3ZS1633-1XX00-0YA0</b>	1	1 unit 42H
		<b>Runtime software</b> for execution of the AS module in an automation system (single license), Type of delivery: License without software and documentation	▶	<b>3ZS1633-2XX00-0YB0</b>	1	1 unit 42H

<sup>1)</sup> Detailed information about the Soft Starter ES software program and the SIRIUS 3RW44 Soft Starter block Library for SIMATIC PCS 7 see Chapter 14 "Parameterization, Configuration and Visualization with SIRIUS".

# SIRIUS 3RW Soft Starters

## 3RW44 for High-Feature Applications

3RW44



Version	DT	Article No.	Price per PU	PU (UNIT, SET, M)	PS*	PG	
<b>PC cables</b>							
		<b>For PC/PG communication with SIRIUS 3RW44 soft starters</b>	▶	<b>3UF7940-0AA00-0</b>	1	1 unit	42J
Through the system interface, for connecting to the serial interface of the PC/PG							
3UF7940-0AA00-0							
<b>USB PC cables</b>							
		<b>For PC/PG communication with SIRIUS 3RW44 soft starters</b>	▶	<b>3UF7941-0AA00-0</b>	1	1 unit	42J
Through the system interface, for connecting to the USB interface of the PC/PG							
3UF7941-0AA00-0							
<b>USB/serial adapters</b>							
	B	<b>For connecting the PC cable to the USB interface of a PC</b>		<b>3UF7946-0AA00-0</b>	1	1 unit	42J
We recommend, in conjunction with 3RW44 soft starter, using SIMOCODE pro 3UF7, 3RK3 Modular Safety System, ET 200S/ECOFAS/ET 200pro motor starters, AS-i safety monitor, AS-i analyzer							
<b>Communication modules</b>							
		<b>Optional PROFIBUS communication modules</b>	▶	<b>3RW4900-0KC00</b>	1	1 unit	42H
For 3RW44 soft starter integration in the PROFIBUS network with DPV1 slave functionality. With firmware version E04 and higher (or date of manufacture 01.05.2009 and later) of the module, DPV1 operation of the soft starter on a Y-link is also possible (< only DPV0 operation possible with E04).							
3RW4900-0KC00							
		<b>Optional PROFINET communication modules</b>	▶	<b>3RW4900-0NC00</b>	1	1 unit	42H
For 3RW44 soft starter integration in the PROFINET network, suitable for devices with firmware version E12 or higher							
3RW4900-0NC00							
<b>External display and operator module</b>							
		For indicating and operating the functions provided by the soft starter using an externally mounted display and operator module in degree of protection IP54 (e.g. in the control cabinet door)	▶	<b>3RW4900-0AC00</b>	1	1 unit	42H
3RW4900-0AC00							
		<b>Connection cable</b>					
From the device interface (serial) of the 3RW44 soft starter to the external display and operator module							
		• Length 0.5 m, flat	▶	<b>3UF7932-0AA00-0</b>	1	1 unit	42J
		• Length 0.5 m, round	▶	<b>3UF7932-0BA00-0</b>	1	1 unit	42J
		• Length 1.0 m, round	▶	<b>3UF7937-0BA00-0</b>	1	1 unit	42J
		• Length 2.5 m, round	▶	<b>3UF7933-0BA00-0</b>	1	1 unit	42J



# SIRIUS 3RW Soft Starters

## 3RW44 for High-Feature Applications

3RW44

For soft starters	Version	DT	Article No.	Price per PU	PU (UNIT, SET, M)	PS*	PG
Type							
<b>Box terminal blocks for soft starters</b>							
 3RT19	<b>Box terminal block</b> (2 units are required for each device)						
	3RW442.	Included in the scope of supply					
	3RW443.	<ul style="list-style-type: none"> <li>Up to 70 mm<sup>2</sup></li> <li>Up to 120 mm<sup>2</sup></li> </ul>	▶	<b>3RT1955-4G</b>	1	1 unit	41B
		<b>Auxiliary conductor connection for box terminals</b>	B	<b>3TX7500-0A</b>	1	1 unit	41B
	3RW444.	<ul style="list-style-type: none"> <li>Up to 240 mm<sup>2</sup> (with auxiliary conductor connection)</li> </ul>	▶	<b>3RT1966-4G</b>	1	1 unit	41B
<b>Covers for soft starters</b>							
<b>Terminal covers for box terminals</b>							
Additional touch protection to be fitted at the box terminals (2 units required per device)							
	3RW442. and 3RW443.		▶	<b>3RT1956-4EA2</b>	1	1 unit	41B
	3RW444.		▶	<b>3RT1966-4EA2</b>	1	1 unit	41B
 3RT19.6-4EA1	<b>Terminal covers for cable lugs and busbar connections</b>						
	3RW442. and 3RW443.	For complying with the voltage clearances and as touch protection (2 units required per contactor)	▶	<b>3RT1956-4EA1</b>	1	1 unit	41B
	3RW444.	Also fits on mounted box terminals.	▶	<b>3RT1966-4EA1</b>	1	1 unit	41B
<b>Manual 3RW44<sup>1)</sup></b>							

<sup>1)</sup> The operating instructions for 3RW44 (3ZX1012-0RW44-0AA0) are included in the scope of supply of the soft starter, or are available – like the manual – as PDF downloads from the Service&Support portal at [www.siemens.com/industrial-controls/support](http://www.siemens.com/industrial-controls/support) → "Switching Devices" → "Soft Starters and Solid-State Switching Devices" → "SIRIUS 3RW Soft Starters".

### Spare parts

For soft starters	Version	DT	Article No.	Price per PU	PU (UNIT, SET, M)	PS*	PG
Type							
<b>Fans</b>							
 3RW49	<b>Fans</b>						
	3RW442. and 3RW443.	115 V AC 230 V AC	▶	<b>3RW49 36-8VX30</b>	1	1 unit	42G
			▶	<b>3RW49 36-8VX40</b>	1	1 unit	42G
	3RW444.	115 V AC 230 V AC	▶	<b>3RW49 47-8VX30</b>	1	1 unit	42G
			▶	<b>3RW49 47-8VX40</b>	1	1 unit	42G
	3RW445. and 3RW446. <sup>1)</sup>	115 V AC 230 V AC	▶	<b>3RW49 57-8VX30</b>	1	1 unit	42H
			▶	<b>3RW49 57-8VX40</b>	1	1 unit	42H
3RW446. <sup>2)</sup>	115 V AC 230 V AC	▶	<b>3RW49 66-8VX30</b>	1	1 unit	42H	
		▶	<b>3RW49 66-8VX40</b>	1	1 unit	42H	

<sup>1)</sup> 3RW446. mounting on output side.

<sup>2)</sup> For mounting on front side.

# SIRIUS 3RW Soft Starters

## 3RW44 for High-Feature Applications

3RW44

### More information

#### Application examples for normal starting (CLASS 10)

**Normal starting CLASS 10** (up to 20 s with 350%  $I_{n\ motor}$ , one start per hour)  
The soft starter rating can be selected to be as high as the rating of the motor used

Application	Conveyor belts	Roller conveyors	Compressors	Small fans <sup>1)</sup>	Pumps	Hydraulic pumps
<b>Starting parameters</b>						
• Voltage ramp and current limiting						
- Starting voltage	%	70	60	50	30	30
- Starting time	s	10	10	10	10	10
- Current limit value		deactivated	deactivated	$4 \times I_M$	$4 \times I_M$	deactivated
• Torque ramp						
- Start torque		60	50	40	20	10
- Final torque		150	150	150	150	150
- Starting time		10	10	10	10	10
• Breakaway pulse		Deactivated (0 ms)	Deactivated (0 ms)	Deactivated (0 ms)	Deactivated (0 ms)	Deactivated (0 ms)
<b>Ramp-down mode</b>						
		Smooth ramp-down	Smooth ramp-down	Free ramp-down	Free ramp-down	Pump ramp-down
						Free ramp-down

#### Application examples for heavy starting (CLASS 20)

**Heavy starting CLASS 20** (up to 40 s with 350%  $I_{n\ motor}$ , one start per hour)  
The soft starter has to be selected one performance class higher than the motor used

Application	Stirrers	Centrifuges	Milling machines
<b>Starting parameters</b>			
• Voltage ramp and current limiting			
- Starting voltage	%	30	30
- Starting time	s	30	30
- Current limit value		$4 \times I_M$	$4 \times I_M$
• Torque ramp			
- Start torque		30	30
- Final torque		150	150
- Starting time		30	30
• Breakaway pulse		deactivated (0 ms)	deactivated (0 ms)
<b>Ramp-down mode</b>			
		Free ramp-down	Free ramp-down or DC braking

#### Application examples for very heavy starting (CLASS 30)

**Very heavy starting CLASS 30** (up to 60 s with 350%  $I_{n\ motor}$ , one start per hour)  
The soft starter has to be selected two performance classes higher than the motor used

Application	Large fans <sup>2)</sup>	Mills	Breakers	Circular saws/bandsaws
<b>Starting parameters</b>				
• Voltage ramp and current limiting				
- Starting voltage	%	30	50	30
- Starting time	s	60	60	60
- Current limit value		$4 \times I_M$	$4 \times I_M$	$4 \times I_M$
• Torque ramp				
- Start torque		20	50	20
- Final torque		150	150	150
- Starting time		60	60	60
• Breakaway pulse		deactivated (0 ms)	80 %, 300 ms	deactivated (0 ms)
<b>Ramp-down mode</b>				
		Free ramp-down	Free ramp-down	Free ramp-down

<sup>1)</sup> The mass inertia of the fan is <10 times the mass inertia of the motor.

<sup>2)</sup> The mass inertia of the fan is  $\geq 10$  times the mass inertia of the motor.

#### Note:

These tables present sample set values and device dimensions. They are intended only for the purposes of information and are not binding. The set values depend on the application in question and must be optimized during commissioning.

The soft starter dimensions should be checked where necessary with the help of Technical Assistance.

# SIRIUS 3RW Soft Starters

## 3RW44 for High-Feature Applications

3RW44

### Circuit concept

The SIRIUS 3RW44 soft starters can be operated in two different types of circuit:

- **Inline circuit**  
The controls for isolating and protecting the motor are simply connected in series with the soft starter. The motor is connected to the soft starter with three cables.
- **Inside-delta circuit**  
The wiring is similar to that of wye-delta starters. The phases of the soft starter are connected in series with the individual motor windings. The soft starter then only has to carry the phase current, amounting to about 58 % of the rated motor current (conductor current).

Comparison of the types of circuit:

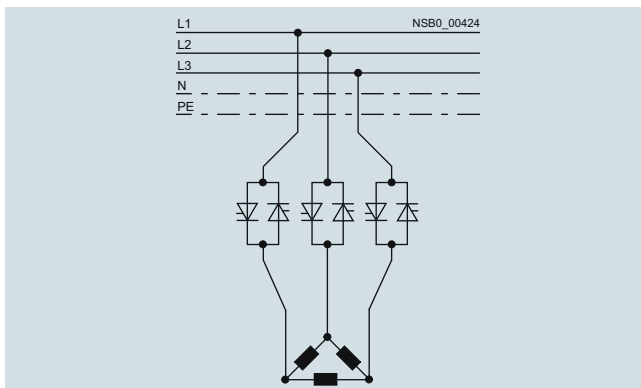

Inline circuit:  
Rated current  $I_g$  corresponds to the rated motor current  $I_n$ ,  
3 cables to the motor

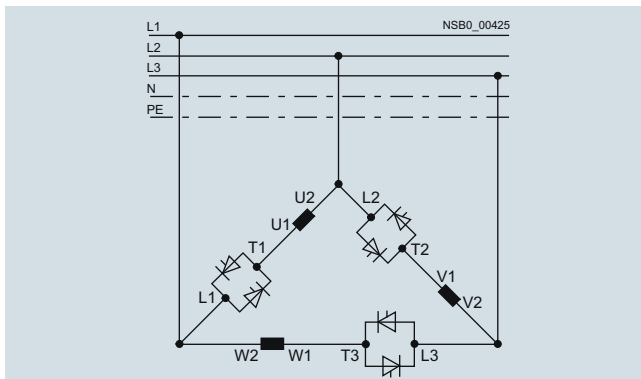

Inside-delta circuit:  
Rated current  $I_g$  corresponds to approx. 58 % of the rated motor  
current  $I_n$ , 6 cables to the motor (as with wye-delta starters)

### Which circuit?

Using the inline circuit involves the lowest wiring outlay. If the soft starter to motor connections are long, this circuit is preferable.

The wiring complexity is twice as high when using the inside-delta circuit, but a smaller device can be used with the same rating.

Thanks to the choice of operating mode between the inline circuit and inside-delta circuit, it is always possible to select the most favorable solution.

The braking function is possible only in the inline circuit.

### Configuration

The solid-state 3RW44 soft starters are designed for normal starting. In case of heavy starting or increased starting frequency, a larger device must be selected.

For long starting times it is recommended to have a PTC sensor in the motor. This also applies for the stopping modes smooth ramp-down, pump ramp-down and DC braking, because during the ramp-down time in these modes, an additional current loading applies in contrast to free ramp-down.

No capacitive elements are permitted in the motor feeder between the SIRIUS 3RW soft starter and the motor (e.g. no reactive-power compensation equipment). In addition, neither static systems for reactive-power compensation nor dynamic PFC (Power Factor Correction) must be operated in parallel during starting and ramp-down of the soft starter. This is important to prevent faults arising on the compensation equipment and/or the soft starter.

All elements of the main circuit (such as fuses and controls) should be dimensioned for direct starting, following the local short-circuit conditions. Fuses, controls and overload relays must be ordered separately.

A bypass contact system and solid-state overload relay are already integrated in the 3RW44 soft starter and therefore do not have to be ordered separately.

The harmonic component load for starting currents must be taken into consideration for the selection of motor starter protectors (selection of release).

### Note:

When three-phase motors are switched on, voltage drops occur as a rule on starters of all types (direct-on-line starters, wye-delta starters, soft starters). The infeed transformer must always be dimensioned such that the voltage dip when starting the motor remains within the permissible tolerance. If the infeed transformer is dimensioned with only a small margin, it is best for the control voltage to be supplied from a separate circuit (independently of the main voltage) in order to avoid the potential switching off of the soft starter.

### Device interface, PROFIBUS DP/PROFINET communication module, Soft Starter ES parameterizing and operating software

The solid-state 3RW44 soft starters have a PC interface for communicating with the Soft Starter ES software or for connecting the external display and operator module. If the optional PROFIBUS/PROFINET communication module is used, the 3RW44 soft starter can be integrated in the PROFIBUS/PROFINET network and communicate using the GSD file or Soft Starter ES Premium software.

### SIRIUS 3RW44 Soft Starter block library for SIMATIC PCS 7

The SIRIUS 3RW44 Soft Starter PCS 7 block library can be used for simple and easy integration of SIRIUS 3RW44 soft starters into the SIMATIC PCS 7 process control system. The SIRIUS 3RW44 Soft Starter PCS 7 block library contains the diagnostics and driver blocks corresponding with the SIMATIC PCS 7 diagnostics and driver concept as well as the elements (symbols and faceplates) required for operator control and process monitoring.

### Manual for SIRIUS 3RW44

In addition to relevant configuration, commissioning, and service information, the manual also contains example circuits and technical specifications for all devices:

<http://support.automation.siemens.com/WW/view/en/21772518>

# Solid-State Switching Devices for Resistive Loads

## General data

### Overview

Type	Solid-state relays		Solid-state contactors		Function modules						
	Single-phase	Three-phase	Single-phase	Three-phase	Converters	Load monitoring		Heating current monitoring	Power controllers	Power regulators	
	22.5 mm	45 mm	45 mm			Basic	Extended				
<b>Usage</b>											
Simple use of existing solid-state relays	<input type="checkbox"/>	<input checked="" type="checkbox"/>	<input type="checkbox"/>	<input type="checkbox"/>	<input type="checkbox"/>	--	--	--	--	--	--
Complete unit "Ready to use"	<input type="checkbox"/>	<input type="checkbox"/>	<input type="checkbox"/>	<input checked="" type="checkbox"/>	<input checked="" type="checkbox"/>	--	--	--	--	--	--
Space-saving	<input checked="" type="checkbox"/>	--	<input checked="" type="checkbox"/>	<input checked="" type="checkbox"/>	<input checked="" type="checkbox"/>	<input checked="" type="checkbox"/>	<input checked="" type="checkbox"/>	--	--	--	--
Can be extended with modular function modules	<input checked="" type="checkbox"/>	--	1)	<input checked="" type="checkbox"/>	1)	--	--	--	--	--	--
Frequent switching and monitoring of loads and solid-state relays/solid-state contactors	--	--	--	--	--	<input checked="" type="checkbox"/>	<input checked="" type="checkbox"/>	<input checked="" type="checkbox"/>	<input checked="" type="checkbox"/>	<input checked="" type="checkbox"/>	<input checked="" type="checkbox"/>
Monitoring of up to 6 partial loads	--	--	--	--	--	<input checked="" type="checkbox"/>	--	<input checked="" type="checkbox"/>	<input checked="" type="checkbox"/>	<input checked="" type="checkbox"/>	--
Monitoring of more than 6 partial loads	--	--	--	--	--	--	--	<input checked="" type="checkbox"/>	--	--	--
Control of the heating power through an analog input	--	--	--	--	--	<input checked="" type="checkbox"/>	--	--	--	<input checked="" type="checkbox"/>	<input checked="" type="checkbox"/>
Power control	--	--	--	--	--	--	--	--	--	--	<input checked="" type="checkbox"/>
<b>Startup</b>											
Easy setting of setpoint values with "Teach" button	--	--	--	--	--	<input checked="" type="checkbox"/>	<input checked="" type="checkbox"/>	--	<input checked="" type="checkbox"/>	<input checked="" type="checkbox"/>	<input checked="" type="checkbox"/>
"Remote Teach" input for setting setpoints	--	--	--	--	--	--	--	<input checked="" type="checkbox"/>	--	--	--
<b>Mounting</b>											
Mounting onto mounting rails or mounting plates	--	--	--	<input checked="" type="checkbox"/>	<input checked="" type="checkbox"/>	--	--	--	--	--	--
Can be snapped directly onto a solid-state relay or contactor	--	--	--	--	--	<input checked="" type="checkbox"/>	<input checked="" type="checkbox"/>	<input checked="" type="checkbox"/>	<input checked="" type="checkbox"/>	<input checked="" type="checkbox"/>	<input checked="" type="checkbox"/>
For use with "Coolplate" heat sink	<input checked="" type="checkbox"/>	<input checked="" type="checkbox"/>	<input checked="" type="checkbox"/>	--	--	--	--	--	--	--	--
<b>Cable routing</b>											
Connection of load circuit as for control-gear	<input checked="" type="checkbox"/>	--	<input checked="" type="checkbox"/>	<input checked="" type="checkbox"/>	<input checked="" type="checkbox"/>	--	<input checked="" type="checkbox"/>	<input checked="" type="checkbox"/>	<input checked="" type="checkbox"/>	<input checked="" type="checkbox"/>	<input checked="" type="checkbox"/>
Connection of load circuit from above	--	<input checked="" type="checkbox"/>	--	--	--	--	--	--	--	--	--

- Function available
- Function possible
- Function not possible

1) The converter can also be used with three-phase devices.

## Article No. scheme

Digit of the Article No.	1st - 3rd	4th	5th	6th	7th	8th	9th	10th	11th	12th	
	□□□	□	□	□	□	-	□	□	□	□	
<b>Solid-state switching devices</b>	<b>3 R F</b>										
<b>SIRIUS solid-state switching device generation</b>		□									
<b>Design</b>			□								
<b>Type current</b>				□	□						
<b>Connection type</b>						□					
<b>Switching function</b>							□				
<b>Single-phase or number of controlled phases</b>								□			
<b>Rated control supply voltage</b>									□		
<b>Rated operational voltage</b>										□	
<b>Example</b>	<b>3 R F</b>	<b>2</b>	<b>1</b>	<b>2</b>	<b>0</b>	<b>-</b>	<b>1</b>	<b>A</b>	<b>A</b>	<b>0 4</b>	

## Note:

The Article No. scheme is presented here merely for information purposes and for better understanding of the logic behind the article numbers.

For your orders, please use the article numbers quoted in the catalog in the Selection and ordering data.

## Benefits

**Characteristics**

- Considerable space savings thanks to a width of only 22.5 mm
- Variety of connection methods: Screw terminal, spring-type connection or ring terminal lug, there is no problem – they are all finger-safe
- Flexible for all applications with function modules for retrofitting
- Possibility of fuseless short-circuit proof design

**Benefits**

- Saves time and costs with fast mounting and commissioning, short start-up times and easy wiring
- Extremely long life, low maintenance, rugged and reliable
- Space-saving and safe thanks to side-by-side mounting up to an ambient temperature of +60 °C
- Modular design: Standardized function modules and heat sinks can be used in conjunction with solid-state relays to satisfy individual requirements
- Safety due to lifelong, vibration-resistant and shock-resistant spring-type terminal connection method even under tough conditions

## Application

**Applications**

Example: Plastics processing industry

Thanks to their high switching endurance SIRIUS 3SF2 solid-state switching devices are ideal for controlling electrical heat. This is because the more precise the temperature regulation process has to be, the higher the switching frequency. The accurate regulation of electrical heat is used for example in many processes in the plastics processing industry:

- Band heaters heat the extrudate to the correct temperature in plastic extruders
- Heat emitters heat plastic blanks to the correct temperature
- Heat drums dry plastic granules
- Heating channels keep molds at the correct temperature in order to manufacture different plastic parts without defects

The powerful SIRIUS 3SF2 solid-state relays and contactors can be used for the simultaneous control of several heating loads. By using a load monitoring module the individual partial loads can easily be monitored, and in the event of a failure a signal is generated to be sent to the controller.

See also Chapter 15, "Products for Specific Requirements" → "Heating Control Systems" → "SIPLUS HCS300I heating controller".

**Use in fuseless load feeders**

Compared with the fused configuration of load feeders, short circuit and line protection using miniature circuit breakers is easy to achieve with SIRIUS 3SF2 solid-state relays and contactors.

A special version of the solid-state contactors can be protected against damage in the case of a short circuit with a miniature circuit breaker with type B tripping characteristic. This allows the low-cost and simple design of fuseless load feeders with full protection of the switchgear.

# Solid-State Switching Devices for Resistive Loads

## General data

### Selection and ordering data

#### Inscription labels for 3RF2 series

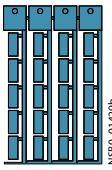
Designation	Labeling area (W x H) mm x mm	Color	DT	Article No.	Price per PU	PU (UNIT, SET, M)	PS*	PG
<b>Blank labels</b>								
 3RT19 00-1SB20 (1 frame = 20 units)	<b>Unit labeling plates for "SIRIUS"<sup>1)</sup></b>	10 x 7	Pastel turquoise	C	<b>3RT19 00-1SB10</b>	100	816 units	41B
		20 x 7	Pastel turquoise	D	<b>3RT19 00-1SB20</b>	100	340 units	41B
	<b>Labels for sticking for SIRIUS</b>	19 x 6	Pastel turquoise	C	<b>3RT19 00-1SB60</b>	100	3060 units	41B
		19 x 6	Zinc yellow	C	<b>3RT19 00-1SD60</b>	100	3060 units	41B

<sup>1)</sup> PC labeling systems for individual inscription of unit labeling plates are available from: murrplastik Systemtechnik GmbH (see Chapter 16, "Appendix" → "External Partners").

### More information

#### Notes on integration in the load feeders

The SIRIUS solid-state switching devices are very easy to integrate into the load feeders thanks to their industrial connection method and design.

Particular attention must however be paid to the circumstances of the installation and ambient conditions, as the performance of the solid-state switching devices is largely dependent on these. Depending on the version, certain restrictions must be observed. Detailed information in relation to solid-state contactors, e.g. on minimum spacing, and in relation to solid-state relays on the choice of heat sink can be found in the technical specifications and the product data sheets (see [Service & Support](#)).

#### Short-circuit and overload protection

Despite the rugged power semiconductors that are used, solid-state switching devices respond more sensitively to short circuits in the load feeder. Consequently, special precautions have to be taken against destruction, depending on the type of design.

Siemens generally recommends using SITOP semiconductor protection fuses. These fuses also provide protection against destruction in the event of a short circuit even when the solid-state contactors and solid-state relays are fully utilized.

Alternatively, if there is lower loading, protection can also be provided by standard fuses or miniature circuit breakers. This protection is achieved by overdimensioning the solid-state switching devices accordingly. The technical specifications and the product data sheets contain details both about the solid-state fuse protection itself and about use of the devices with conventional protection equipment.

#### Electromagnetic compatibility (EMC)

The solid-state switching devices are suitable for interference-free operation in industrial networks without further measures. If they are used in public networks, it may be necessary for conducted interference to be reduced by means of filters.

This does not include the solid-state contactors for resistive loads of the special type 3RF23 ...CA.. "Low Noise". These comply with the class B limit values up to a rated current of 16 A. If other versions are used, and at currents of over 16 A, standard filters can be used in order to comply with the limit values. The decisive factors when it comes to selecting the filters are essentially the current loading and the other parameters (operational voltage, design type, etc.) in the load feeder.

Suitable filters can be ordered from EPCOS AG. For more information see [www.epcos.com](http://www.epcos.com).

#### Product information and technical specifications

For product data sheets with detailed technical specifications, dimensional drawings and characteristic curves, see [www.siemens.com/sirius/support/](http://www.siemens.com/sirius/support/)

For additional information, please enter the article number of the required device under the tab "Product List".

### Overview

#### **Solid-state relays (without heat sink)**

SIRIUS solid-state relays are suitable for surface mounting on existing cooling surfaces. Mounting is quick and easy, involving just two screws. The special technology of the power semiconductor ensures there is excellent thermal contact with the heat sink. Depending on the nature of the heat sink, the capacity reaches up to 88 A on resistive loads.

The solid-state relays are available in three different versions:

- 3RF21 single-phase solid-state relay with a width of 22.5 mm
- 3RF20 single-phase solid-state relay with a width of 45 mm
- 3RF22 three-phase solid-state relay with a width of 45 mm

The 3RF21 and 3RF22 solid-state relays can be expanded with various function modules to adapt them to individual applications.

#### **Version for resistive loads, "zero-point switching"**

This standard version is often used for switching space heaters on and off.

#### **Version for inductive loads, "instantaneous switching"**

In this version the solid-state relay is specifically matched to inductive loads. Whether it is a matter of frequent actuation of the valves in a filling plant or starting and stopping small operating mechanisms in packet distribution systems, operation is carried out safely and noiselessly.

#### **Special "Low noise" version**

Thanks to a special control circuit, this special version can be used in public networks up to 16 A without any additional measures such as interference suppressor filters. As a result, in terms of emitted interference, it conforms to limit value curve class B according to IEC 60947-4-3.

#### **Single-phase solid-state relays with a width of 22.5 mm**

With its compact design and a width of just 22.5 mm, which stays the same even at currents of up to 88 A, the 3RF21 solid-state relay offers an ultra small footprint. The logical connection method, with the power infeed from above and load connection from below, ensures tidy installation in the control cabinet.

#### **Single-phase solid-state relays with a width of 45 mm**

The solid-state relays with a width of 45 mm provide for connection of the power supply lead and the load from above. This makes it easy to replace existing solid-state relays in existing arrangements. The connection of the control cable is as space-saving as the 22.5 mm design, as it is simply plugged on.

#### **Three-phase solid-state relays with a width of 45 mm**

With its compact design and a width of just 45 mm, which stays the same even at currents of up to 55 A, the 3RF22 solid-state relay offers an ultra small footprint. The logical connection method, with the power infeed from above and load connection from below, ensures tidy installation in the control cabinet.

The three-phase solid-state relays are available with

- two-phase control (suitable in particular for circuits without connection to the neutral conductor) and
- three-phase control (suitable for star circuits with connection to the neutral conductor or for applications in which the system requires all phases to be switched)

#### **Selection notes**

When selecting solid-state relays, in addition to information about the network, the load and the ambient conditions it is also necessary to know details of the planned design. The solid-state relays can only conform to their specific technical specifications if they are mounted with appropriate care on an adequately dimensioned heat sink.

The following procedure is recommended:

- Determine the rated current of the load and the mains voltage
- Select the relay design and choose a solid-state relay with higher rated current than the load
- Determine the thermal resistance of the proposed heat sink
- Check the correct relay size with the aid of the diagrams

For more information see [www.siemens.com/solid-state-switching-devices](http://www.siemens.com/solid-state-switching-devices)

# Solid-State Switching Devices for Resistive Loads





## Solid-State Relays

### SIRIUS 3RF21 solid-state relays, single-phase, 22.5 mm

#### Overview

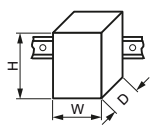
With its compact design and a width of just 22.5 mm, which stays the same even at currents of up to 88 A, the 3RF21 solid-state relay offers an ultra small footprint. The logical connection method, with the power infeed from above and load connection from below, ensures tidy installation in the control cabinet.

#### Technical specifications

Type		3RF21..-1....	3RF21..-2....	3RF21..-3....
Dimensions (W x H x D)	 mm	22.5 x 85 x 48	22.5 x 85 x 48	22.5 x 85 x 48
<b>General data</b>				
<b>Ambient temperature</b>				
• During operation, derating from 40 °C	°C	-25 ... + 60		
• During storage	°C	-55 ... + 80		
<b>Installation altitude</b>	m	0 ... 1000; derating from 1000		
<b>Shock resistance</b> acc. to IEC 60068-2-27	g/ms	15/11		
<b>Vibration resistance</b> acc. to IEC 60068-2-6	g	2		
<b>Degree of protection</b>		IP20		
<b>Electromagnetic compatibility (EMC)</b>				
• Emitted interference		Class A for industrial applications		
- Conducted interference voltage according to IEC 60947-4-3		Class B for residential, business and commercial applications		
- Emitted, high-frequency interference voltage according to IEC 60947-4-3				
• Interference immunity		Contact discharge 4; air discharge 8; behavior criterion 2		
- Electrostatic discharge according to IEC 61000-4-2 (corresponds to degree of severity 3)	kV			
- Induced RF fields according to IEC 61000-4-6	MHz	0.15 ... 80; 140 dBµV; behavior criterion 1		
- Burst acc. to IEC 61000-4-4	kV	2/5.0 kHz; behavior criterion 2		
- Surge acc. to IEC 61000-4-5	kV	Conductor - ground 2; conductor - conductor 1; behavior criterion 2		
<b>Mounting</b>				
• Screws <sup>1)</sup>		2 x M4		
• Tightening torque	Nm	1.5		
<b>Connection type</b>		 <b>Screw terminals</b>	 <b>Spring-type terminals</b>	 <b>Ring terminal lug connections</b>
<b>Connection, main contacts</b>				
• Conductor cross-sections				
- Solid	mm <sup>2</sup>	2 x (1.5 ... 2.5) <sup>2)</sup> , 2 x (2.5 ... 6) <sup>2)</sup>	2 x (0.5 ... 2.5)	--
- Finely stranded with end sleeve	mm <sup>2</sup>	2 x (1 ... 2.5) <sup>2)</sup> , 2 x (2.5 ... 6) <sup>2)</sup> , 1 x 10	2 x (0.5 ... 1.5)	--
- Finely stranded without end sleeve	mm <sup>2</sup>	--	2 x (0.5 ... 2.5)	--
- Solid or stranded, AWG cables	mm <sup>2</sup>	2 x (AWG 14 ... 10)	2 x (AWG 18 ... 14)	--
• Terminal screws		M4	--	M5
• Tightening torque	Nm	2 ... 2.5	--	2.5 ... 2
	lb.in	7 ... 10.3	--	10.3 ... 7
• Cable lugs		--	--	--
- According to DIN 46234				5-2.5, 5-6, 5-10, 5-16, 5-25
- According to JIS C 2805				R 2-5, R 5.5-5, R 8-5, R 14-5
- Width, maximum	mm			12
<b>Connection, auxiliary/control contacts</b>				
• Conductor cross-sections	mm	1 x (0.5 ... 2.5), 2 x (0.5 ... 1.0)	0.5 ... 2.5	1 x (0.5 ... 2.5), 2 x (0.5 ... 1.0)
	AWG	20 ... 12	20 ... 12	20 ... 12
• Stripped length	mm	7	10	7
• Terminal screw		M3	--	M3
• Tightening torque	Nm	0.5 ... 0.6	--	0.5 ... 0.6
	lb.in	4.5 ... 5.3	--	4.5 ... 5.3

<sup>1)</sup> Not included in the scope of supply.

<sup>2)</sup> If two different conductor cross-sections are connected to one clamping point, both cross-sections must lie in one of the ranges specified.



# Solid-State Switching Devices for Resistive Loads

## Solid-State Relays

SIRIUS 3RF21 solid-state relays,  
single-phase, 22.5 mm

Type	$I_{\max}^{1)}$ at $R_{\text{thha}}/T_U = 40\text{ °C}$		$I_e$ according to IEC 60947-4-3 at $R_{\text{thha}}/T_U = 40\text{ °C}$		$I_e$ according to UL/CSA at $R_{\text{thha}}/T_U = 50\text{ °C}$		Power loss at $I_{\max}$ W	Minimum load current A	Off-state current mA
	A	K/W	A	K/W	A	K/W			
<b>Main circuit</b>									
3RF2120-.....	20	2.0	20	1.7	20	1.3	28.6	0.1	10
3RF2130-1....	30	1.1	30	0.79	30	0.56	44.2	0.5	10
3RF2150-1....	50	0.68	50	0.48	50	0.33	66	0.5	10
3RF2150-2....	50	0.68	20	2.6	20	2.9	66	0.5	10
3RF2150-3....	50	0.68	50	0.48	50	0.33	66	0.5	10
3RF2170-1....	70	0.40	50	0.77	50	0.6	94	0.5	10
3RF2190-1....	88	0.33	50	0.94	50	0.85	118	0.5	10
3RF2190-2....	88	0.33	20	2.8	20	3.5	118	0.5	10
3RF2190-3....	88	0.33	88	0.22	83	0.19	118	0.5	10

<sup>1)</sup> The current  $I_{\max}$  provides information about the performance of the solid-state relay. The actual permitted rated operational current  $I_e$  can be smaller depending on the connection method and cooling conditions.

### Note:

The required heat sinks for the corresponding load currents can be determined from the characteristic curves (see page 6/70, "More Information"). The minimum thickness values for the mounting surface must be observed.

Type	Rated peak withstand current $I_{\text{tsm}}$	$I^2t$ value
	A	A <sup>2</sup> s
<b>Main circuit</b>		
3RF2120-.....	200	200
3RF2130-...A.2	300	450
3RF2130-...A.4	300	450
3RF2130-...A.5	300	450
3RF2130-...A.6	400	800
3RF2150-.....	600	1800
3RF2170-...A.2	1200	7200
3RF2170-...A.4	1200	7200
3RF2170-...A.5	1200	7200
3RF2170-...A.6	1150	6600
3RF2190-.....	1150	6600

Type		3RF21...-...2	3RF21...-...4	3RF21...-...5	3RF21...-...6
<b>Main circuit</b>					
Rated operational voltage $U_e$	V AC	24 ... 230	48 ... 460	48 ... 600	48 ... 600
• Operating range	V AC	20 ... 253	40 ... 506	40 ... 660	40 ... 660
• Rated frequency	Hz	50/60 ± 10 %			
Rated insulation voltage $U_i$	V	600			
Blocking voltage	V	800	1200	1600	
Rate of voltage rise	V/μs	1000			

Type		3RF21...-...0.	3RF21...-...1.	3RF21...-...2.	3RF21...-...4.
<b>Control circuit</b>					
Method of operation		DC operation	AC/DC operation	AC operation	DC operation
Rated control supply voltage $U_s$	V	24	24 AC 24 DC	110 ... 230	4 ... 30
Rated frequency of the control supply voltage	Hz	--	50/60 ± 10 %	--	50/60 ± 10 %
Control supply voltage, max.	V	30	26.5 AC 30 DC	253	30
Typical actuating current	mA	20/Low Power: 6.5 <sup>1)</sup>	20	20	15
Response voltage	V	15	14 AC 15 DC	90	4
Drop-out voltage	V	5	5 AC 5 DC	40	1
<b>Operating times</b>					
• ON-delay	ms	1 + max. one half-wave <sup>2)</sup>	10 + max. one half-wave <sup>2)</sup>	40 + max. one half-wave <sup>2)</sup>	1 + max. one half-wave <sup>2)</sup>
• OFF-delay	ms	1 + max. one half-wave	15 + max. one half-wave	40 + max. one half-wave	1 + max. one half-wave

<sup>1)</sup> Applies to the version "Low Power" 3RF21 ...-AA...-0KNO

<sup>2)</sup> Only for zero-point switching devices.

# Solid-State Switching Devices for Resistive Loads

## Solid-State Relays

### SIRIUS 3RF21 solid-state relays, single-phase, 22.5 mm

#### Circuit diagrams

DC control supply voltage

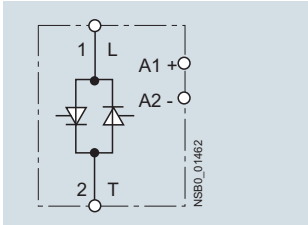

AC control supply voltage

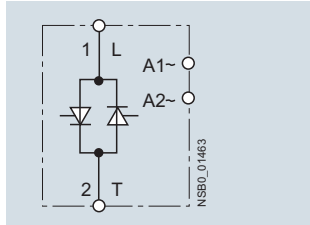

#### Selection and ordering data

Type current <sup>1)</sup>	Rated control supply voltage $U_s$	DT	Screw terminals <sup>2)</sup>	PU (UNIT, SET, M)	PS*	PG
A	V		Configurator	Article No.	Price per PU	
<b>Zero-point switching</b>						
<b>Rated operational voltage <math>U_e</math> 24 ... 230 V AC</b>						
	20	24 DC	A	<b>3RF2120-1AA02</b>	1	1 unit 41C
	30		A	<b>3RF2130-1AA02</b>	1	1 unit 41C
	50		A	<b>3RF2150-1AA02</b>	1	1 unit 41C
	70		A	<b>3RF2170-1AA02</b>	1	1 unit 41C
	90		A	<b>3RF2190-1AA02</b>	1	1 unit 41C
	20	110 ... 230 AC	A	<b>3RF2120-1AA22</b>	1	1 unit 41C
	30		A	<b>3RF2130-1AA22</b>	1	1 unit 41C
	50		B	<b>3RF2150-1AA22</b>	1	1 unit 41C
	70		B	<b>3RF2170-1AA22</b>	1	1 unit 41C
	90		B	<b>3RF2190-1AA22</b>	1	1 unit 41C
	20	4 ... 30 DC	B	<b>3RF2120-1AA42</b>	1	1 unit 41C
	30		A	<b>3RF2130-1AA42</b>	1	1 unit 41C
<b>Zero-point switching</b>						
<b>Rated operational voltage <math>U_e</math> 48 ... 460 V AC</b>						
	20	24 DC	A	<b>3RF2120-1AA04</b>	1	1 unit 41C
	30		A	<b>3RF2130-1AA04</b>	1	1 unit 41C
	50		A	<b>3RF2150-1AA04</b>	1	1 unit 41C
	70		A	<b>3RF2170-1AA04</b>	1	1 unit 41C
	90		A	<b>3RF2190-1AA04</b>	1	1 unit 41C
	20	24 AC/DC	B	<b>3RF2150-1AA14</b>	1	1 unit 41C
	20	110 ... 230 AC	A	<b>3RF2120-1AA24</b>	1	1 unit 41C
	30		A	<b>3RF2130-1AA24</b>	1	1 unit 41C
	50		B	<b>3RF2150-1AA24</b>	1	1 unit 41C
	70		A	<b>3RF2170-1AA24</b>	1	1 unit 41C
	90		B	<b>3RF2190-1AA24</b>	1	1 unit 41C
<b>Zero-point switching</b>						
<b>Rated operational voltage <math>U_e</math> 48 ... 600 V AC</b>						
	70	24 DC Low Power	B	<b>3RF2170-1AA05-0KNO</b>	1	1 unit 41C
	20	4 ... 30 DC	B	<b>3RF2120-1AA45</b>	1	1 unit 41C
	30		B	<b>3RF2130-1AA45</b>	1	1 unit 41C
	50		B	<b>3RF2150-1AA45</b>	1	1 unit 41C
	70		A	<b>3RF2170-1AA45</b>	1	1 unit 41C
	90		B	<b>3RF2190-1AA45</b>	1	1 unit 41C
<b>Zero-point switching · Blocking voltage 1 600 V,</b>						
<b>Rated operational voltage <math>U_e</math> 48 ... 600 V AC</b>						
	30	24 DC	A	<b>3RF2130-1AA06</b>	1	1 unit 41C
	50		A	<b>3RF2150-1AA06</b>	1	1 unit 41C
	70		B	<b>3RF2170-1AA06</b>	1	1 unit 41C
	90		B	<b>3RF2190-1AA06</b>	1	1 unit 41C
	30	110 ... 230 AC	B	<b>3RF2130-1AA26</b>	1	1 unit 41C
	50		B	<b>3RF2150-1AA26</b>	1	1 unit 41C
	70		B	<b>3RF2170-1AA26</b>	1	1 unit 41C
	90		B	<b>3RF2190-1AA26</b>	1	1 unit 41C

Online configurator see [www.siemens.com/sirius/configurators](http://www.siemens.com/sirius/configurators)

1) The type current provides information about the performance capacity of the solid-state relay. The actual permitted rated operational current  $I_e$  can be smaller depending on the connection method and cooling conditions.

2) Please note that this version can only be used for a rated current of up to approx. 50 A and a conductor cross-section of 10 mm<sup>2</sup>.

Other rated control supply voltages on request.

## Solid-State Switching Devices for Resistive Loads

## Solid-State Relays

SIRIUS 3RF21 solid-state relays,  
single-phase, 22.5 mm

Type current <sup>1)</sup>	Rated control supply voltage $U_s$	DT	Screw terminals <sup>2)</sup>	Configurator	Article No.	Price per PU	PU (UNIT, SET, M)	PS*	PG
A	V								
<b>Instantaneous switching</b> Rated operational voltage $U_e$ 24 ... 230 V AC									
50	110 ... 230 AC	B	3RF2150-1BA22				1	1 unit	41C
<b>Instantaneous switching</b> Rated operational voltage $U_e$ 48 ... 460 V AC									
20	24 DC	B	3RF2120-1BA04				1	1 unit	41C
30		B	3RF2130-1BA04				1	1 unit	41C
50		B	3RF2150-1BA04				1	1 unit	41C
70		B	3RF2170-1BA04				1	1 unit	41C
90		B	3RF2190-1BA04				1	1 unit	41C
<b>Instantaneous switching · Blocking voltage 1 600 V,</b> Rated operational voltage $U_e$ 48 ... 600 V AC									
50	24 DC	B	3RF2150-1BA06				1	1 unit	41C
<b>Low noise<sup>3)</sup> · Zero-point switching</b> Rated operational voltage $U_e$ 48 ... 460 V AC									
70	24 DC	B	3RF2170-1CA04				1	1 unit	41C

Online configurator see [www.siemens.com/sirius/configurators](http://www.siemens.com/sirius/configurators)

1) The type current provides information about the performance capacity of the solid-state relay. The actual permitted rated operational current  $I_e$  can be smaller depending on the connection method and cooling conditions.

2) Please note that this version can only be used for a rated current of up to approx. 50 A and a conductor cross-section of 10 mm<sup>2</sup>.

3) See page 6/71.

Other rated control supply voltages on request.

Type current <sup>1)</sup>	Rated control supply voltage $U_s$	DT	Spring-type terminals <sup>2)</sup>	Configurator	Article No.	Price per PU	PU (UNIT, SET, M)	PS*	PG
A	V								
<b>Zero-point switching</b> Rated operational voltage $U_e$ 24 ... 230 V AC									
20	24 DC	A	3RF2120-2AA02				1	1 unit	41C
50		B	3RF2150-2AA02				1	1 unit	41C
90		B	3RF2190-2AA02				1	1 unit	41C
20	110 ... 230 AC	B	3RF2120-2AA22				1	1 unit	41C
50		B	3RF2150-2AA22				1	1 unit	41C
90		B	3RF2190-2AA22				1	1 unit	41C
20	4 ... 30 DC	B	3RF2120-2AA42				1	1 unit	41C
<b>Zero-point switching</b> Rated operational voltage $U_e$ 48 ... 460 V AC									
20	24 DC	A	3RF2120-2AA04				1	1 unit	41C
50		B	3RF2150-2AA04				1	1 unit	41C
90		B	3RF2190-2AA04				1	1 unit	41C
50	24 AC/DC	B	3RF2150-2AA14				1	1 unit	41C
20	110 ... 230 AC	B	3RF2120-2AA24				1	1 unit	41C
50		B	3RF2150-2AA24				1	1 unit	41C
90		B	3RF2190-2AA24				1	1 unit	41C
<b>Zero-point switching</b> Rated operational voltage $U_e$ 48 ... 600 V AC									
20	4 ... 30 DC	B	3RF2120-2AA45				1	1 unit	41C
<b>Zero-point switching · Blocking voltage 1 600 V,</b> Rated operational voltage $U_e$ 48 ... 600 V AC									
50	24 DC	B	3RF2150-2AA06				1	1 unit	41C
90		B	3RF2190-2AA06				1	1 unit	41C
50	110 ... 230 AC	B	3RF2150-2AA26				1	1 unit	41C
90		B	3RF2190-2AA26				1	1 unit	41C

Online configurator see [www.siemens.com/sirius/configurators](http://www.siemens.com/sirius/configurators)

1) The type current provides information about the performance capacity of the solid-state relay. The actual permitted rated operational current  $I_e$  can be smaller depending on the connection method and cooling conditions.

2) Please note that the version with spring-type terminals can only be used for a rated current of up to approx. 20 A and a conductor cross-section of 2.5 mm<sup>2</sup>. Higher currents can be achieved by connecting two conductors per terminal.

Other rated control supply voltages on request.

# Solid-State Switching Devices for Resistive Loads

## Solid-State Relays

### SIRIUS 3RF21 solid-state relays, single-phase, 22.5 mm



Type current <sup>1)</sup>	Rated control supply voltage $U_s$	DT	Ring terminal lug connection	Configurator	Article No.	Price per PU	PU (UNIT, SET, M)	PS*	PG
A	V								
<b>Zero-point switching</b> Rated operational voltage $U_e$ 24 ... 230 V AC									
	20	24 DC	B		<b>3RF2120-3AA02</b>		1	1 unit	41C
	50		B		<b>3RF2150-3AA02</b>		1	1 unit	41C
	90		B		<b>3RF2190-3AA02</b>		1	1 unit	41C
	20	110 ... 230 AC	B		<b>3RF2120-3AA22</b>		1	1 unit	41C
	50		B		<b>3RF2150-3AA22</b>		1	1 unit	41C
	90		B		<b>3RF2190-3AA22</b>		1	1 unit	41C
<b>Zero-point switching</b> Rated operational voltage $U_e$ 48 ... 460 V AC									
	20	24 DC	B		<b>3RF2120-3AA04</b>		1	1 unit	41C
	50		B		<b>3RF2150-3AA04</b>		1	1 unit	41C
	90		B		<b>3RF2190-3AA04</b>		1	1 unit	41C
	20	110 ... 230 AC	B		<b>3RF2120-3AA24</b>		1	1 unit	41C
	50		B		<b>3RF2150-3AA24</b>		1	1 unit	41C
	90		B		<b>3RF2190-3AA24</b>		1	1 unit	41C
	90	4 ... 30 DC	B		<b>3RF2190-3AA44</b>		1	1 unit	41C
<b>Zero-point switching · Blocking voltage 1 600 V,</b> Rated operational voltage $U_e$ 48 ... 600 V AC									
	50	24 DC	B		<b>3RF2150-3AA06</b>		1	1 unit	41C
	90		B		<b>3RF2190-3AA06</b>		1	1 unit	41C
	50	110 ... 230 AC	B		<b>3RF2150-3AA26</b>		1	1 unit	41C
	90		B		<b>3RF2190-3AA26</b>		1	1 unit	41C

3RF2120-3AA02

Online configurator see [www.siemens.com/sirius/configurators](http://www.siemens.com/sirius/configurators)

<sup>1)</sup> The type current provides information about the performance capacity of the solid-state relay. The actual permitted rated operational current  $I_e$  can be smaller depending on the connection method and cooling conditions.

Other rated control supply voltages on request.

Version	DT	Article No.	Price per PU	PU (UNIT, SET, M)	PS*	PG
<b>Optional accessories</b>						
	A	<b>Spring-type terminals</b> <b>3RA2908-1A</b>		1	1 unit	41B
<p><b>Screwdrivers</b> for all SIRIUS devices with spring-type terminals Length approx. 200 mm, size 3.0 mm x 0.5 mm, titanium gray/black, partially insulated</p>						
3RA2908-1A						
	A	<b>Ring terminal lug connection</b> <b>3RF2900-3PA88</b>		1	10 units	41C
<p><b>Terminal covers</b> for 3RF21 solid-state relays and 3RF23 solid-state contactors with ring terminal lug connection (After simple adaptation, this terminal cover can also be used for screw terminals).</p>						
3RF2900-3PA88						

# Solid-State Switching Devices for Resistive Loads



## Solid-State Relays

**SIRIUS 3RF20 solid-state relays,  
single-phase, 45 mm**

### Overview

The solid-state relays with a width of 45 mm provide for connection of the power supply lead and the load from above. This makes it easy to replace existing solid-state relays in existing arrangements. The connection of the control cable also saves space in much the same way as the 22.5 mm design, as it is simply plugged on.

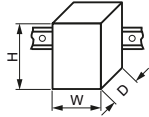
### Technical specifications

Type		<b>3RF20..-1....</b>	<b>3RF20..-4....</b>
Dimensions (W x H x D)	 mm	45 x 58 x 48	45 x 58 x 48
<b>General data</b>			
<b>Ambient temperature</b>			
• During operation, derating from 40 °C	°C	-25 ... +60	
• During storage	°C	-55 ... +80	
<b>Installation altitude</b>	m	0 ... 1 000; derating from 1 000	
<b>Shock resistance</b> acc. to IEC 60068-2-27	g/ms	15 / 11	
<b>Vibration resistance</b> acc. to IEC 60068-2-6	g	2	
<b>Degree of protection</b>		IP20	
<b>Electromagnetic compatibility (EMC)</b>			
• Emitted interference			
- Conducted interference voltage according to IEC 60947-4-3		Class A for industrial applications	
- Emitted, high-frequency interference voltage according to IEC 60947-4-3		Class B for residential, business and commercial applications	
• Interference immunity			
- Electrostatic discharge according to IEC 61000-4-2 (corresponds to degree of severity 3)	kV	Contact discharge 4; air discharge 8; behavior criterion 2	
- Induced RF fields according to IEC 61000-4-6	MHz	0.15 ... 80; 140 dBµV; behavior criterion 1	
- Burst acc. to IEC 61000-4-4	kV	2/5.0 kHz; behavior criterion 2	
- Surge acc. to IEC 61000-4-5	kV	Conductor - ground 2; conductor - conductor 1; behavior criterion 2	
<b>Mounting</b>			
• Screws <sup>1)</sup>		2 x M4	
• Tightening torque	Nm	1.5	
<b>Connection type</b>		 <b>Screw terminals</b>	 <b>Spring-type terminals</b>
<b>Connection, main contacts</b>			
• Conductor cross-sections			
- Solid	mm <sup>2</sup>	2 x (1.5 ... 2.5) <sup>2</sup> , 2 x (2.5 ... 6) <sup>2</sup>	--
- Finely stranded with end sleeve	mm <sup>2</sup>	2 x (1 ... 2.5) <sup>2</sup> , 2 x (2.5 ... 6) <sup>2</sup> , 1 x 10	--
- Solid or stranded, AWG cables		2 x (AWG 14 ... 10)	--
• Terminal screw		M4	--
• Tightening torque	Nm	2 ... 2.5	--
	lb.in	7 ... 10.3	--
<b>Connection, auxiliary/control contacts</b>			
• Conductor cross-sections	mm <sup>2</sup>	1 x (0.5 ... 2.5), 2 x (0.5 ... 1.0), AWG 20 ... 12	0.5 ... 2.5, AWG 20 ... 12
• Stripped length	mm	7	10
• Terminal screw		M3	--
• Tightening torque	Nm	0.5 ... 0.6	--
	lb.in	4.5 ... 5.3	--

<sup>1)</sup> Not included in the scope of supply.

<sup>2)</sup> If two different conductor cross-sections are connected to one clamping point, both cross-sections must lie in one of the ranges specified.

# Solid-State Switching Devices for Resistive Loads

## Solid-State Relays

### SIRIUS 3RF20 solid-state relays, single-phase, 45 mm

Type	$I_{\max}^1)$ at $R_{\text{thha}}/T_u = 40\text{ °C}$		$I_e$ according to IEC 60947-4-3 at $R_{\text{thha}}/T_u = 40\text{ °C}$		$I_e$ according to UL/CSA at $R_{\text{thha}}/T_u = 50\text{ °C}$		Power loss at $I_{\max}$	Minimum load current	Off-state current
	A	K/W	A	K/W	A	K/W			
<b>Main circuit</b>									
3RF2020-1.A..	20	2.0	20	1.7	20	1.3	28.6	0.1	10
3RF2030-1.A..	30	1.1	30	0.79	30	0.56	44.2	0.5	10
3RF2050-1.A..	50	0.68	50	0.48	50	0.33	66	0.5	10
3RF2070-1.A..	70	0.40	50	0.77	50	0.6	94	0.5	10
3RF2090-1.A..	88	0.33	50	0.94	50	0.85	118	0.5	10

1) The current  $I_{\max}$  provides information about the performance of the solid-state relay. The actual permitted rated operational current  $I_e$  can be smaller depending on the connection method and cooling conditions.

#### Note:

The required heat sinks for the corresponding load currents can be determined from the characteristic curves (see page 6/70, "More Information"). The minimum thickness values for the mounting surface must be observed.

Type	Rated peak withstand current $I_{\text{tsm}}$	$I^2t$ value
	A	A <sup>2</sup> s
<b>Main circuit</b>		
3RF2020-1.A..	200	200
3RF2030-1.A.2	300	450
3RF2030-1.A.4	300	450
3RF2030-1.A.6	400	800
3RF2050-1.A..	600	1 800
3RF2070-1.A.2	1 200	7 200
3RF2070-1.A.4	1 200	7 200
3RF2070-1.A.5	1 200	7 200
3RF2070-1.A.6	1 150	6 600
3RF2090-1.A..	1 150	6 600

Type		3RF20.0-1.A.2	3RF20.0-1.A.4	3RF20.0-1.A.5	3RF20.0-1.A.6
<b>Main circuit</b>					
Rated operational voltage $U_e$	V AC	24 ... 230	48 ... 460	48 ... 600	48 ... 600
• Operating range	V AC	20 ... 253	40 ... 506	40 ... 660	40 ... 660
• Rated frequency	Hz	50/60 ± 10 %			
Rated insulation voltage $U_i$	V	600			
Blocking voltage	V	800	1 200	1 600	
Rate of voltage rise	V/μs	1 000			

Type		3RF20.0-1.A0.	3RF20.0-1.A2.	3RF20.0-1.A4.
<b>Control circuit</b>				
Method of operation		DC operation	AC operation	DC operation
Rated control supply voltage $U_s$	V	24	110 ... 230	4 ... 30
Rated frequ. of the control supply voltage	Hz	--	50/60 ± 10 %	--
Control supply voltage, max.	V	30	253	30
Typical actuating current	mA	20	15	20
Response voltage	V	15	90	4
Drop-out voltage	V	5	40	1
<b>Operating times</b>				
• ON-delay	ms	1 + max. one half-wave <sup>1)</sup>	40 + max. one half-wave <sup>1)</sup>	1 + max. one half-wave <sup>1)</sup>
• OFF-delay	ms	1 + max. one half-wave	40 + max. one half-wave	1 + max. one half-wave

1) Only for zero-point switching devices.

#### Circuit diagrams

DC control supply voltage

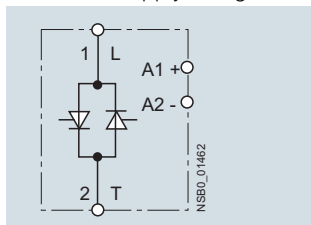

AC control supply voltage

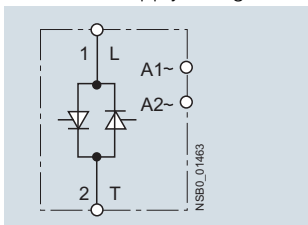

## Selection and ordering data

Type current <sup>1)</sup>	Rated control supply voltage $U_s$	DT	Screw terminals <sup>2)</sup>	⊕	PU (UNIT, SET, M)	PS*	PG
A	V		Configurator	⚙			
			Article No.	Price per PU			
<b>Zero-point switching</b> Rated operational voltage $U_e$ 24 ... 230 V AC							
	20	24 DC	A	3RF2020-1AA02	1	1 unit	41C
	30		A	3RF2030-1AA02	1	1 unit	41C
	50		A	3RF2050-1AA02	1	1 unit	41C
	70		A	3RF2070-1AA02	1	1 unit	41C
	90		A	3RF2090-1AA02	1	1 unit	41C
	20	110 ... 230 AC	A	3RF2020-1AA22	1	1 unit	41C
	30		A	3RF2030-1AA22	1	1 unit	41C
	50		B	3RF2050-1AA22	1	1 unit	41C
	70		B	3RF2070-1AA22	1	1 unit	41C
	90		B	3RF2090-1AA22	1	1 unit	41C
3RF2020-1AA02	20	4 ... 30 DC	B	3RF2020-1AA42	1	1 unit	41C
	30		B	3RF2030-1AA42	1	1 unit	41C
<b>Zero-point switching</b> Rated operational voltage $U_e$ 48 ... 460 V AC							
	20	24 DC	A	3RF2020-1AA04	1	1 unit	41C
	30		A	3RF2030-1AA04	1	1 unit	41C
	50		A	3RF2050-1AA04	1	1 unit	41C
	70		A	3RF2070-1AA04	1	1 unit	41C
	90		A	3RF2090-1AA04	1	1 unit	41C
	20	110 ... 230 AC	B	3RF2020-1AA24	1	1 unit	41C
	30		B	3RF2030-1AA24	1	1 unit	41C
	50		B	3RF2050-1AA24	1	1 unit	41C
	70		B	3RF2070-1AA24	1	1 unit	41C
	90		B	3RF2090-1AA24	1	1 unit	41C
	50	4 ... 30 DC	A	3RF2050-1AA44	1	1 unit	41C
<b>Zero-point switching</b> Rated operational voltage $U_e$ 48 ... 600 V AC							
	20	4 ... 30 DC	B	3RF2020-1AA45	1	1 unit	41C
	50		B	3RF2050-1AA45	1	1 unit	41C
	70		A	3RF2070-1AA45	1	1 unit	41C
	90		B	3RF2090-1AA45	1	1 unit	41C
<b>Zero-point switching · Blocking voltage 1 600 V, rated operational voltage <math>U_e</math> 48 ... 600 V AC</b>							
	30	24 DC	B	3RF2030-1AA06	1	1 unit	41C
	50		B	3RF2050-1AA06	1	1 unit	41C
	70		B	3RF2070-1AA06	1	1 unit	41C
	90		B	3RF2090-1AA06	1	1 unit	41C
	30	110 ... 230 AC	B	3RF2030-1AA26	1	1 unit	41C
	50		B	3RF2050-1AA26	1	1 unit	41C
	70		B	3RF2070-1AA26	1	1 unit	41C
	90		B	3RF2090-1AA26	1	1 unit	41C
<b>Instantaneous switching</b> Rated operational voltage $U_e$ 48 ... 460 V AC							
	30	24 DC	B	3RF2030-1BA04	1	1 unit	41C

⚙ Online configurator see [www.siemens.com/sirius/configurators](http://www.siemens.com/sirius/configurators)

1) The type current provides information about the performance capacity of the solid-state relay. The actual permitted rated operational current  $I_e$  can be smaller depending on the connection method and cooling conditions.

2) Please note that this version can only be used for a rated current of up to approx. 50 A and a conductor cross-section of 10 mm<sup>2</sup>.

# Solid-State Switching Devices for Resistive Loads

## Solid-State Relays

### SIRIUS 3RF20 solid-state relays, single-phase, 45 mm

Type current <sup>1)</sup>	Rated control supply voltage $U_s$ DT	Screw terminals + spring-type terminals (control current side)	Configurator	PU (UNIT, SET, M)	PS*	PG
A	V	Article No.	Price per PU			

#### Zero-point switching Rated operational voltage $U_e$ 24 ... 230 V AC



3RF2050-4AA02

Online configurator see [www.siemens.com/sirius/configurators](http://www.siemens.com/sirius/configurators)

<sup>1)</sup> The type current provides information about the performance capacity of the solid-state relay. The actual permitted rated operational current  $I_e$  can be smaller depending on the connection method and cooling conditions.

50	24 DC	B	3RF2050-4AA02	1	1 unit	41C
----	-------	---	---------------	---	--------	-----



# Solid-State Switching Devices for Resistive Loads

## Solid-State Relays

**SIRIUS 3RF22 solid-state relays,  
three-phase, 45 mm**





### Overview

With its compact design and a width of just 45 mm, which stays the same even at currents of up to 55 A, the 3RF22 solid-state relay offers an ultra small footprint. The logical connection method, with the power infeed from above and load connection from below, ensures tidy installation in the control cabinet.

Important features:

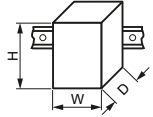
- LED display
- Variety of connection methods
- Plug-in control connection
- Degree of protection IP20
- Zero-point switching
- Two- or three-phase controlled

### Technical specifications

Type		3RF22..-1....	3RF22..-2....	3RF22..-3....
Dimensions (W x H x D)		45 x 95 x 47	45 x 95 x 47	45 x 95 x 47
<b>General data</b>				
<b>Ambient temperature</b>				
• During operation, derating from 40 °C	°C	-25 ... + 60		
• During storage	°C	-55 ... + 80		
<b>Installation altitude</b>	m	0 ... 1 000; > 1 000 ask Technical Assistance		
<b>Shock resistance</b> acc. to IEC 60068-2-27	g/ms	15/11		
<b>Vibration resistance</b> acc. to IEC 60068-2-6	g	2		
<b>Degree of protection</b>		IP20		
<b>Insulation strength</b> at 50/60 Hz (main/control circuit to floor)	V rms	4000		
<b>Electromagnetic compatibility (EMC)</b>				
• Emitted interference - Conducted interference voltage according to IEC 60947-4-3		Class A for industrial applications <sup>1)</sup>		
• Interference immunity - Electrostatic discharge according to IEC 61000-4-2 (corresponds to degree of severity 3) - Induced RF fields according to IEC 61000-4-6 - Burst acc. to IEC 61000-4-4 - Surge acc. to IEC 61000-4-5	kV MHz kV kV	Contact discharge 4; air discharge 8; behavior criterion 2 0.15 ... 80; 140 dBµV; behavior criterion 1 2/5.0 kHz; behavior criterion 2 Conductor - ground 2; conductor - conductor 1; behavior criterion 2		
<b>Mounting</b> • Screws <sup>2)</sup> • Tightening torque	Nm	2 x M4 1.5		
<b>Connection type</b>		 <b>Screw terminals</b>	 <b>Spring-type terminals</b>	 <b>Ring terminal lug connections</b>
<b>Connection, main contacts</b>				
• Conductor cross-sections - Solid	mm <sup>2</sup>	2 x (1.5 ... 2.5) <sup>3)</sup> , 2 x (2.5 ... 6) <sup>3)</sup>		
- Finely stranded with end sleeve	mm <sup>2</sup>	2 x (1 ... 2.5) <sup>3)</sup> , 2 x (2.5 ... 6) <sup>3)</sup> , 1 x 10		
- Finely stranded without end sleeve	mm <sup>2</sup>	--		
- Solid or stranded, AWG cables		2 x (AWG 14 ... 10)		
• Stripped length	mm	10		
• Terminal screws - Tightening torque, ∅ 5 ... 6 mm, PZ 2	Nm lb.in	M4 2 ... 2.5 18 ... 22		
• Cable lugs - According to DIN 46234 - According to JIS C 2805 - Width, maximum	mm	-- -- 5-2.5 ... 5-25 R 2-5 ... R 14-5 12		
<b>Connection, auxiliary/control contacts</b>				
• Conductor cross-sections, with or without end sleeve	mm AWG	1 x (0.5 ... 2.5), 2 x (0.5 ... 1.0) 20 ... 12		
• Stripped length	mm	7		
• Terminal screw - Tightening torque, ∅ 3.5, PZ 1	Nm lb.in	M3 0.5 ... 0.6 4.5 ... 5.3		

<sup>1)</sup> These products were built as Class A devices. The use of these devices in residential areas could result in lead in radio interference. In this case these may be required to introduce additional interference suppression measures.

<sup>2)</sup> Not included in the scope of supply.

<sup>3)</sup> If two different conductor cross-sections are connected to one clamping point, both cross-sections must lie in one of the ranges specified.

# Solid-State Switching Devices for Resistive Loads

## Solid-State Relays

### SIRIUS 3RF22 solid-state relays, three-phase, 45 mm

Type	$I_{\max}^{1)}$ at $R_{\text{thha}}/T_U = 40\text{ °C}$		$I_e$ according to IEC 60947-4-3 at $R_{\text{thha}}/T_U = 40\text{ °C}$		$I_e$ according to UL/CSA at $R_{\text{thha}}/T_U = 50\text{ °C}$		Power loss at $I_{\max}$ W	Minimum load current A	Max. off-state current mA
	A	K/W	A	K/W	A	K/W			
<b>Main circuit</b>									
<b>3RF2230-. AB..</b>	30	0.57	30	0.57	30	0.44	81	0.5	10
<b>3RF2255-1AB..</b>	55	0.18	50	0.27	50	0.19	151	0.5	10
<b>3RF2255-2AB..</b>			20	1.83	20	1.58			
<b>3RF2255-3AB..</b>			50	0.27	50	0.19			
<b>3RF2230-. AC..</b>	30	0.33	30	0.33	30	0.25	122	0.5	10
<b>3RF2255-1AC..</b>	55	0.09	50	0.15	50	0.1	226	0.5	10
<b>3RF2255-2AC..</b>			20	1.19	20	1.02			
<b>3RF2255-3AC..</b>			50	0.15	50	0.1			

1) The current  $I_{\max}$  provides information about the performance of the solid-state relay. The actual permitted rated operational current  $I_e$  can be smaller depending on the connection method and cooling conditions.

#### Note:

The required heat sinks for the corresponding load currents can be determined from the characteristic curves (see page 6/70, "More Information"). The minimum thickness values for the mounting surface must be observed.

Type	Rated peak withstand current $I_{\text{tsm}}$ A	$I^2t$ value A <sup>2</sup> s
<b>Main circuit</b>		
<b>3RF2230-...5</b>	300	450
<b>3RF2255-...5</b>	600	1800

Type	<b>3RF22...-AB.5</b>		<b>3RF22...-AC.5</b>
<b>Main circuit</b>			
<b>Controlled phases</b>	2-phase		3-phase
<b>Rated operational voltage <math>U_e</math></b>	V AC	48 ... 600	48 ... 600
• Operating range	V AC	40 ... 660	40 ... 660
• Rated frequency	Hz	50/60 ± 10 %	50/60 ± 10 %
<b>Rated insulation voltage <math>U_i</math></b>	V	600	600
<b>Rated impulse withstand voltage <math>U_{\text{imp}}</math></b>	kV	6	6
<b>Blocking voltage</b>	V	1 200	1 200
<b>Rate of voltage rise</b>	V/μs	1 000	1 000

Type	<b>3RF22...-A.3.</b>		<b>3RF22...-A.4.</b>
<b>Control circuit</b>			
<b>Method of operation</b>	AC operation		DC operation
<b>Rated control supply voltage <math>U_s</math></b>	V	110	4 ... 30
<b>Rated frequency</b> of the control supply voltage	Hz	50/60 ± 10 %	--
<b>Control supply voltage, max.</b>	V	121	30
<b>Typical actuating current</b>	mA	15	30
<b>Response voltage</b>	V	90	4
<b>Drop-out voltage</b>	V	< 40	1
<b>Operating times</b>			
• ON-delay	ms	40 + max. one half-wave	1 + max. one half-wave
• OFF-delay	ms	40 + max. one half-wave	1 + max. one half-wave

#### Circuit diagrams

Two-phase controlled,  
DC control supply voltage

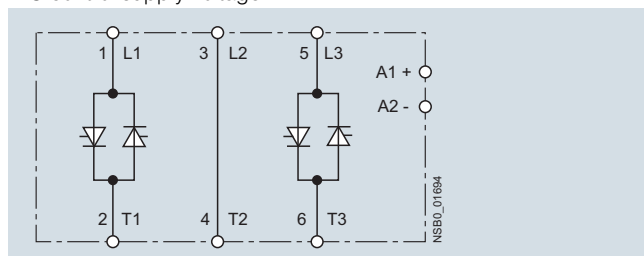

Three-phase controlled,  
DC control supply voltage

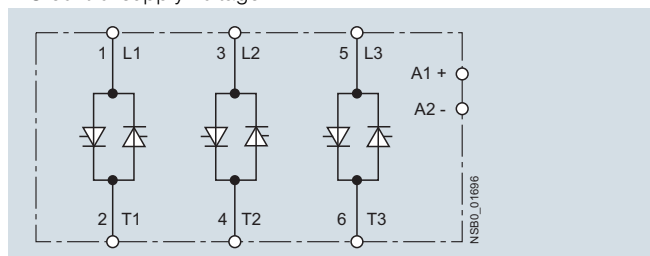

## Selection and ordering data

Type current <sup>1)</sup>	Rated control supply voltage $U_s$	DT	Screw terminals <sup>2)</sup>	⊕	PU (UNIT, SET, M)	PS*	PG
A	V		Configurator	⚙			
			Article No.		Price per PU		

Zero-point switching  
Rated operational voltage  $U_e$  48 ... 600 V AC

3RF2230-1AB45

<b>Two-phase controlled</b>							
30	110 AC	B	3RF2230-1AB35	1	1 unit	41C	
55		B	3RF2255-1AB35	1	1 unit	41C	
30	4 ... 30 DC	B	3RF2230-1AB45	1	1 unit	41C	
55		B	3RF2255-1AB45	1	1 unit	41C	
<b>Three-phase controlled</b>							
30	110 AC	B	3RF2230-1AC35	1	1 unit	41C	
55		B	3RF2255-1AC35	1	1 unit	41C	
30	4 ... 30 DC	A	3RF2230-1AC45	1	1 unit	41C	
55		B	3RF2255-1AC45	1	1 unit	41C	

Type current <sup>1)</sup>	Rated control supply voltage $U_s$	DT	Spring-type terminals <sup>3)</sup>	⊕	PU (UNIT, SET, M)	PS*	PG
A	V		Configurator	⚙			
			Article No.		Price per PU		

Zero-point switching  
Rated operational voltage  $U_e$  48 ... 600 V AC

3RF2230-2AB45

<b>Two-phase controlled</b>							
30	4 ... 30 DC	B	3RF2230-2AB45	1	1 unit	41C	
55		B	3RF2255-2AB45	1	1 unit	41C	
<b>Three-phase controlled</b>							
30	4 ... 30 DC	B	3RF2230-2AC45	1	1 unit	41C	
55		B	3RF2255-2AC45	1	1 unit	41C	

Type current <sup>1)</sup>	Rated control supply voltage $U_s$	DT	Ring terminal lug connection	⊕	PU (UNIT, SET, M)	PS*	PG
A	V		Configurator	⚙			
			Article No.		Price per PU		

Zero-point switching  
Rated operational voltage  $U_e$  48 ... 600 V AC

3RF2230-3AB45

<b>Two-phase controlled</b>							
30	4 ... 30 DC	B	3RF2230-3AB45	1	1 unit	41C	
55		B	3RF2255-3AB45	1	1 unit	41C	
<b>Three-phase controlled</b>							
30	4 ... 30 DC	B	3RF2230-3AC45	1	1 unit	41C	
55		B	3RF2255-3AC45	1	1 unit	41C	

⚙ Online configurator see [www.siemens.com/sirius/configurators](http://www.siemens.com/sirius/configurators)

- <sup>1)</sup> The type current provides information about the performance capacity of the solid-state relay. The actual permitted rated operational current  $I_e$  can be smaller depending on the connection method and cooling conditions.
- <sup>2)</sup> Please note that the version with an M4 screw connection can only be used for a rated current of up to approx. 50 A and a conductor cross-section of 10 mm<sup>2</sup>.
- <sup>3)</sup> Please note that the version with spring-type terminals can only be used for a rated current of up to approx. 20 A and a conductor cross-section of 2.5 mm<sup>2</sup>. Higher currents can be achieved by connecting two conductors per terminal.

# Solid-State Switching Devices for Resistive Loads

## Solid-State Contactors

### General data

#### Overview

##### Solid-state contactors (with heat sink)

The complete units consist of a solid-state relay plus optimized heat sink, and are therefore ready to use. They offer defined rated currents to make selection as easy as possible. Depending on the version, current intensities of up to 88 A are achieved. Like all of our solid-state switching devices, one of their particular advantages is their compact and space-saving design.

With their insulated mounting foot they can easily be snapped onto a standard mounting rail, or they can be mounted on support plates with fixing screws. This insulation enables them to be used in circuits with protective extra-low voltage (PELV) or safety extra-low voltage (SELV) in building management systems. For other applications, such as for extended personal safety, the heat sink can be grounded through a screw terminal.

The solid-state contactors are available in 2 different versions:

- 3RF23 single-phase solid-state contactors
- 3RF24 three-phase solid-state contactors

##### Single-phase versions

The 3RF23 solid-state contactors can be expanded with various function modules to adapt them to individual applications.

##### Version for resistive loads, "zero-point switching"

This standard version is often used for switching space heaters on and off.

##### Version for inductive loads, "instantaneous switching"

In this version the solid-state contactor is specifically matched to inductive loads. Whether it is a matter of frequent actuation of the valves in a filling plant or starting and stopping small operating mechanisms in packet distribution systems, operation is carried out safely and noiselessly.

##### Special "Low noise" version

Thanks to a special control circuit, this special version can be used in public networks up to 16 A without any additional measures such as interference suppressor filters. As a result, in terms of emitted interference, it conforms to limit value curve class B according to IEC 60947-4-3.

##### Special "Short-circuit proof" version

Skillful matching of the power semiconductor with the performance capacity of the solid-state contactor means that "short-circuit strength" can be achieved with a standard miniature circuit breaker. In combination with a B-type MCB or a conventional line protection fuse, the result is a short-circuit proof feeder.

In order to achieve problem-free short-circuit protection by means of miniature circuit breakers, however, certain boundary conditions must be observed. As the magnitude and duration of the short-circuit current are determined not only by the short-circuit breaking response of the miniature circuit breaker but also the properties of the wiring system, such as the internal resistance of the input to the network and damping by controls and cables, particular attention must also be paid to these parameters. The necessary cable lengths are therefore shown for the main factor, the line resistance, in the table below.

The following miniature circuit breakers with a B characteristic and 10 kA or 6 kA breaking capacity protect the 3RF23 ..-DA.. solid-state contactors in the event of short circuits on the load and the specified conductor cross-sections and lengths:

Rated current of the miniature circuit breaker	Example of type <sup>1)</sup>	Max. conductor cross-section	Minimum cable length from contactor to load
6 A	5SY4 106-6	1 mm <sup>2</sup>	5 m
10 A	5SY4 110-6	1.5 mm <sup>2</sup>	8 m
16 A	5SY4 116-6	1.5 mm <sup>2</sup>	12 m
16 A	5SY4 116-6	2.5 mm <sup>2</sup>	20 m
20 A	5SY4 120-6	2.5 mm <sup>2</sup>	20 m
25 A	5SY4 125-6	2.5 mm <sup>2</sup>	26 m

<sup>1)</sup> The miniature circuit breakers can be used up to a maximum rated voltage of 480 V!

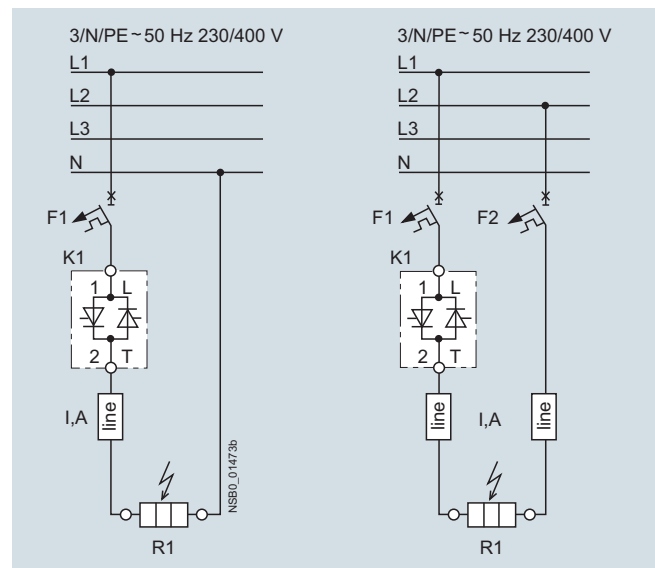

Solid-state contactor protection

The setup and installation above can also be used for the solid-state relays with a  $I^2t$  value of at least 6 600 A<sup>2</sup>s.

##### Three-phase versions

The three-phase solid-state contactors for resistive loads up to 50 A are available with

- two-phase control (suitable in particular for circuits without connection to the neutral conductor) and
- three-phase control (suitable for star circuits with connection to the neutral conductor or for applications in which the system requires all phases to be switched)

The converter function module can be snapped onto both versions for the simple power control of AC loads by means of analog signals.

- Check the correct contactor size with the aid of the rated current diagram, taking account of the installation conditions



# Solid-State Switching Devices for Resistive Loads

## Solid-State Contactors

**SIRIUS 3RF23 solid-state contactors,  
single-phase**

### Technical specifications

Type	3RF23...-A...	3RF23...-B...	3RF23...-C...	3RF23...-D...
Dimensions (W x H x D)	See page 6/86			
<b>General data</b>				
<b>Ambient temperature</b>				
• During operation, derating from 40 °C	°C	-25 ... +60		
• During storage	°C	-55 ... +80		
<b>Installation altitude</b>	m	0 ... 1000; derating from 1 000		
<b>Shock resistance</b> acc. to IEC 60068-2-27	g/ms	15/11		
<b>Vibration resistance</b> acc. to IEC 60068-2-6	g	2		
<b>Degree of protection</b>	IP20			
<b>Electromagnetic compatibility (EMC)</b>				
• Emitted interference according to IEC 60947-4-3				
- Conducted interference voltage	Class A for industrial applications		Class A for industrial applications; Class B for residential, business and commercial applications up to 16 A, AC-51 Low Noise	Class A for industrial applications
- Emitted, high-frequency interference voltage	Class B for residential, business and commercial applications			
• Interference immunity				
- Electrostatic discharge according to IEC 61000-4-2 (corresponds to degree of severity 3)	kV	Contact discharge 4; air discharge 8; behavior criterion 2		
- Induced RF fields according to IEC 61000-4-6	MHz	0.15 ... 80; 140 dBµV; behavior criterion 1		
- Burst acc. to IEC 61000-4-4	kV	2/5.0 kHz; behavior criterion 2		
- Surge acc. to IEC 61000-4-5	kV	Conductor - ground 2; conductor - conductor 1; behavior criterion 2		

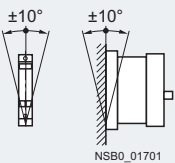
Type	3RF23...-1....	3RF23...-2....	3RF23...-3....
<b>General data</b>			
<b>Connection type</b>	 <b>Screw terminals</b>	 <b>Spring-type terminals</b>	 <b>Ring terminal lug connections</b>
<b>Connection, main contacts</b>			
• Conductor cross-section			
- Solid	mm <sup>2</sup>	2 x (1.5 ... 2.5) <sup>1)</sup> , 2 x (2.5 ... 6) <sup>1)</sup>	2 x (0.5 ... 2.5)
- Finely stranded with end sleeve	mm <sup>2</sup>	2 x (1 ... 2.5) <sup>1)</sup> , 2 x (2.5 ... 6) <sup>1)</sup> , 1 x 10	2 x (0.5 ... 1.5)
- Finely stranded without end sleeve	mm <sup>2</sup>	--	2 x (0.5 ... 2.5)
- Solid or stranded, AWG cables		2 x (AWG 14 ... 10)	2 x (AWG 18 ... 14)
• Terminal screws		M4	M5
• Tightening torque	Nm	2 ... 2.5	--
	lb.in	7 ... 10.3	7 ... 10.3
• Cable lugs		--	--
- According to DIN 46234			5-2.5, 5-6, 5-10, 5-16, 5-25
- According to JIS C 2805			R 2-5, R 5.5-5, R 8-5, R 14-5
- Width, maximum	mm	--	12
<b>Connection, auxiliary/control contacts</b>			
• Conductor cross-section	mm	1 x (0.5 ... 2.5) <sup>1)</sup> , 2 x (0.5 ... 1.0)	1 x (0.5 ... 2.5), 2 x (0.5 ... 1.0)
	AWG	AWG 20 ... 12	AWG 20 ... 12
• Stripped length	mm	7	7
• Terminal screw		M3	M3
• Tightening torque	Nm	0.5 ... 0.6	0.5 ... 0.6
	lb.in	4.5 ... 5.3	4.5 ... 5.3
<b>Grounding screw<sup>2)</sup></b>			
• Size (standard screw)	M4		
<b>Permissible mounting position</b>			
			

<sup>1)</sup> If two different conductor cross-sections are connected to one clamping point, both cross-sections must lie in one of the ranges specified.

<sup>2)</sup> The screw is not included in the scope of supply.

# Solid-State Switching Devices for Resistive Loads

## Solid-State Contactors

### SIRIUS 3RF23 solid-state contactors, single-phase

Type		3RF23...2	3RF23...4	3RF23...5	3RF23...6
<b>Main circuit</b>					
<b>Rated operational voltage <math>U_e</math></b>	V AC	24 ... 230	48 ... 460	48 ... 600	48 ... 600
• Operating range	V AC	20 ... 253	40 ... 506	40 ... 660	40 ... 660
• Rated frequency	Hz	50/60 ± 10 %			
<b>Rated insulation voltage <math>U_i</math></b>	V	600			
<b>Blocking voltage</b>	V	800	1200		1600
<b>Rate of voltage rise</b>	V/μs	1000			

Type		3RF23...0.	3RF23...1.	3RF23...2	3RF23...4.
<b>Control circuit</b>					
<b>Method of operation</b>		DC operation	AC/DC operation	AC operation	DC operation
<b>Rated control supply voltage <math>U_s</math></b>	V	24 DC	24 AC 24 DC	110 ... 230 AC	4 ... 30 DC
<b>Rated frequency of the control supply voltage</b>	Hz	--	50/60 ± 10 %	50/60 ± 10 %	--
<b>Actuating voltage, max.</b>	V	30	26.5 AC 30 DC	253	30
<b>Typical actuating current</b>	mA	20/Low Power: <math>10^{1}</math>	20 20	15	20
<b>Response voltage</b>	V	15	14 AC 15 DC	90	4
<b>Drop-out voltage</b>	V	5	5 AC 55 DC	40	1
<b>Operating times</b>					
• ON-delay	ms	1 + max. one half-wave <sup>2)</sup>	10 + max. one half-wave <sup>2)</sup>	40 + max. one half-wave <sup>2)</sup>	1 + max. one half-wave <sup>2)</sup>
• OFF-delay	ms	1 + max. one half-wave	15 + max. one half-wave	40 + max. one half-wave	1 + max. one half-wave

<sup>1)</sup> Applies to the version "Low Power" 3RF23 ...AA...**OKNO**

<sup>2)</sup> Only for zero-point switching devices.

Type	Type current <sup>1)</sup> $I_{AC-51}$ A	Dimensions (W x H x D) (including heat sink) mm
------	--	---

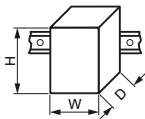

<b>Main circuit</b>		
3RF2310-AA..	10.5	22.5 x 100 x 89
3RF2320-AA.. 3RF2320-CA.. 3RF2320-DA..	20	22.5 x 100 x 135.5
3RF2330-AA.. 3RF2330-CA..	30	30 x 100 x 151
3RF2330-DA..	30	22.5 x 100 x 135.5
3RF2340-AA..	40	67 x 100 x 151
3RF2350-AA..	50	67 x 100 x 151
3RF2370-AA..	70	135 x 100 x 157.5
3RF2390-AA..	88	180 x 200 x 157.5

<sup>1)</sup> The type current provides information about the performance of the solid-state contactor. The actual permitted rated operational current  $I_e$  can be smaller depending on the connection method and start-up conditions.

# Solid-State Switching Devices for Resistive Loads

## Solid-State Contactors

### SIRIUS 3RF23 solid-state contactors, single-phase

Type	Type current AC-51 <sup>1)</sup>			Power loss at $I_{max}$	Minimum load current	Off-state current	Rated peak withstand current $I_{tsm}$	$I^2t$ value
	For $I_{max}$ at 40 °C	Acc. to IEC 60947-4-3 at 40 °C	Acc. to UL/CSA at 50 °C					
	A	A	A	W	A	mA	A	A <sup>2</sup> s
<b>Main circuit</b>								
3RF2310-AA.2 3RF2310-AA.4 3RF2310-AA.5 3RF2310-AA.6	10.5	7.5	9.6	11	0.1	10	200 200 200 400	200 200 200 800
3RF2320-AA.2 3RF2320-AA.4 3RF2320-AA.5 3RF2320-AA.6 3RF2320-CA.2 3RF2320-CA.4 3RF2320-DA.2 3RF2320-DA.4	20	13.2	17.6	20	0.5	10 10 10 10 25 25 10 10	600 600 600 600 600 600 1150 1150	1800 1800 1800 1800 1800 1800 6600 6600
3RF2330-AA.2 3RF2330-AA.4 3RF2330-AA.5 3RF2330-AA.6 3RF2330-CA.2 3RF2330-DA.4	30	22	27	33	0.5	10 10 10 10 25 10	600 600 600 600 600 1150	1800 1800 1800 1800 1800 6600
3RF2340-AA.2 3RF2340-AA.4 3RF2340-AA.5 3RF2340-AA.6	40	33	36	44	0.5	10	1200 1200 1200 1150	7200 7200 7200 6600
3RF2350-AA.2 3RF2350-AA.4 3RF2350-AA.5 3RF2350-AA.6	50	36	45	54	0.5	10	1150	6600
3RF2370-AA.2 3RF2370-AA.4 3RF2370-AA.5 3RF2370-AA.6	70	70	62	83	0.5	10	1150	6600
3RF2390-AA.2 3RF2390-AA.4 3RF2390-AA.5 3RF2390-AA.6	88	88	80	117	0.5	10	1150	6600

<sup>1)</sup> The type current provides information about the performance of the solid-state contactor. The actual permitted rated operational current  $I_e$  can be smaller depending on the connection method and start-up conditions.

Type	Type current AC-51 <sup>1)</sup>			Type current AC-15		Power loss at $I_{max}$	Minimum load current	Off-state current	Rated peak withstand current $I_{tsm}$	$I^2t$ value
	For $I_{max}$ at 40 °C	Acc. to IEC 60947-4-3 for 40 °C	Acc. to UL/CSA at 50 °C	$10 \times I_e$ for 60 ms	Parameters					
	A	A	A	A		W	A	mA	A	A <sup>2</sup> s
<b>Main circuit</b>										
3RF2310-BA.2 3RF2310-BA.4 3RF2310-BA.6	10.5	7.5	9.6	6	1200 1/h 50 % ON period	11	0.1	10	200 200 400	200 200 800
3RF2320-BA.2 3RF2320-BA.4 3RF2320-BA.6	20	13.2	17.6	12	1200 1/h 50 % ON period	20	0.5	10	600	1800
3RF2330-BA.2 3RF2330-BA.4 3RF2330-BA.6	30	22	27	15	1200 1/h 50 % ON period	33	0.5	10	600	1800
3RF2340-BA.2 3RF2340-BA.4 3RF2340-BA.6	40	33	36	20	1200 1/h 50 % ON period	44	0.5	10	1200 1200 1150	7200 7200 6600
3RF2350-BA.2 3RF2350-BA.4 3RF2350-BA.6	50	36	45	25	1200 1/h 50 % ON period	54	0.5	10	1150	6600
3RF2370-BA.2 3RF2370-BA.4 3RF2370-BA.6	70	70	62	27.5	1200 1/h 50 % ON period	83	0.5	10	1150	6600
3RF2390-BA.2 3RF2390-BA.4 3RF2390-BA.6	88	88	80	30	1200 1/h 50 % ON period	117	0.5	10	1150	6600

<sup>1)</sup> The type current provides information about the performance of the solid-state contactor. The actual permitted rated operational current  $I_e$  can be smaller depending on the connection method and start-up conditions.

# Solid-State Switching Devices for Resistive Loads

## Solid-State Contactors

### SIRIUS 3RF23 solid-state contactors, single-phase

#### Circuit diagrams

DC control supply voltage

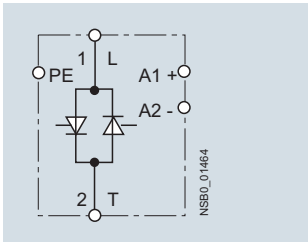

AC control supply voltage

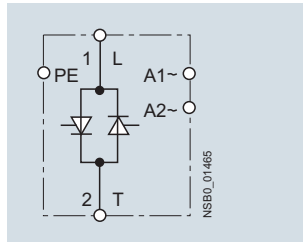

#### Selection and ordering data

##### Selection notes

The solid-state contactors are selected on the basis of details of the network, the load and the ambient conditions. As the solid-state contactors are already equipped with an optimally matched heat sink, the selection process is considerably simpler than that for solid-state relays.

The following procedure is recommended:

- Determine the rated current of the load and the mains voltage
- Select a solid-state contactor with the same or higher rated current than the load

Type current <sup>1)</sup> $I_{max}$	Rated control supply voltage $U_c$ DT	Screw terminals	PU (UNIT, SET, M)	PS*	PG
A	V	Configurator	Price per PU		
		Article No.			

#### Zero-point switching Rated operational voltage $U_e$ 24 ... 230 V AC



3RF2310-1

10.5	24 DC	A	3RF2310-1AA02	1	1 unit	41C
20		A	3RF2320-1AA02	1	1 unit	41C
30		A	3RF2330-1AA02	1	1 unit	41C
40		A	3RF2340-1AA02	1	1 unit	41C
50		A	3RF2350-1AA02	1	1 unit	41C
20	24 DC Low Power	A	3RF2320-1AA02-0KN0	1	1 unit	41C
10.5	24 AC/DC	A	3RF2310-1AA12	1	1 unit	41C
10.5	110 ... 230 AC	A	3RF2310-1AA22	1	1 unit	41C
20		A	3RF2320-1AA22	1	1 unit	41C
30		A	3RF2330-1AA22	1	1 unit	41C
40		B	3RF2340-1AA22	1	1 unit	41C
50		A	3RF2350-1AA22	1	1 unit	41C

#### Zero-point switching Rated operational voltage $U_e$ 48 ... 460 V AC



3RF2320-1

10.5	24 DC	A	3RF2310-1AA04	1	1 unit	41C
20		A	3RF2320-1AA04	1	1 unit	41C
30		A	3RF2330-1AA04	1	1 unit	41C
40		A	3RF2340-1AA04	1	1 unit	41C
50		A	3RF2350-1AA04	1	1 unit	41C
10.5	24 DC Low Power	A	3RF2310-1AA04-0KN0	1	1 unit	41C
10.5	24 AC/DC	A	3RF2310-1AA14	1	1 unit	41C
20		B	3RF2320-1AA14	1	1 unit	41C
30		A	3RF2330-1AA14	1	1 unit	41C
40		B	3RF2340-1AA14	1	1 unit	41C
50		B	3RF2350-1AA14	1	1 unit	41C
10.5	110 ... 230 AC	A	3RF2310-1AA24	1	1 unit	41C
20		A	3RF2320-1AA24	1	1 unit	41C
30		A	3RF2330-1AA24	1	1 unit	41C
40		A	3RF2340-1AA24	1	1 unit	41C
50		A	3RF2350-1AA24	1	1 unit	41C
10.5	4 ... 30 DC	A	3RF2310-1AA44	1	1 unit	41C
20		A	3RF2320-1AA44	1	1 unit	41C
30		A	3RF2330-1AA44	1	1 unit	41C

Online configurator see [www.siemens.com/sirius/configurators](http://www.siemens.com/sirius/configurators)

<sup>1)</sup> The type current provides information about the performance of the solid-state contactor. The actual permitted rated operational current  $I_e$  can be smaller depending on the connection method and start-up conditions. For derating characteristic curves see page 6/70, "More Information".





Other rated control supply voltages on request.



# Solid-State Switching Devices for Resistive Loads

## Solid-State Contactors

### SIRIUS 3RF23 solid-state contactors, single-phase

Type current <sup>1)</sup> $I_{max}$	Rated control supply voltage $U_s$ DT		Screw terminals	⊕	PU (UNIT, SET, M)	PS*	PG	
A	V		Configurator	⚙				
			Article No.		Price per PU			
<b>Zero-point switching</b> Rated operational voltage $U_e$ 48 ... 600 V AC								
30	110 ... 230 AC	B	<b>3RF2330-1AA25</b>		1	1 unit	41C	
10.5	4 ... 30 DC	A	<b>3RF2310-1AA45</b>		1	1 unit	41C	
20		B	<b>3RF2320-1AA45</b>		1	1 unit	41C	
30		A	<b>3RF2330-1AA45</b>		1	1 unit	41C	
40		A	<b>3RF2340-1AA45</b>		1	1 unit	41C	
50		A	<b>3RF2350-1AA45</b>		1	1 unit	41C	
<b>Zero-point switching · Blocking voltage 1 600 V, rated operational voltage <math>U_e</math> 48 ... 600 V AC</b>								
	10.5	24 DC	B	<b>3RF2310-1AA06</b>		1	1 unit	41C
	20		A	<b>3RF2320-1AA06</b>		1	1 unit	41C
	30		A	<b>3RF2330-1AA06</b>		1	1 unit	41C
	40		B	<b>3RF2340-1AA06</b>		1	1 unit	41C
	50		B	<b>3RF2350-1AA06</b>		1	1 unit	41C
	10.5	110 ... 230 AC	B	<b>3RF2310-1AA26</b>		1	1 unit	41C
	20		B	<b>3RF2320-1AA26</b>		1	1 unit	41C
	30		B	<b>3RF2330-1AA26</b>		1	1 unit	41C
	40		B	<b>3RF2340-1AA26</b>		1	1 unit	41C
	50		B	<b>3RF2350-1AA26</b>		1	1 unit	41C
<b>Low noise<sup>2)</sup> · Zero-point switching</b> Rated operational voltage $U_e$ 24 ... 230 V AC								
	20	24 DC	B	<b>3RF2320-1CA02</b>		1	1 unit	41C
	30		B	<b>3RF2330-1CA02</b>		1	1 unit	41C
	20	110 ... 230 AC	B	<b>3RF2320-1CA22</b>		1	1 unit	41C
<b>Low noise<sup>2)</sup> · Zero-point switching</b> Rated operational voltage $U_e$ 48 ... 460 V AC								
	20	24 DC	B	<b>3RF2320-1CA04</b>		1	1 unit	41C
	20	110 ... 230 AC	B	<b>3RF2320-1CA24</b>		1	1 unit	41C
	20	4 ... 30 DC	A	<b>3RF2320-1CA44</b>		1	1 unit	41C
<b>Short-circuit proof with B-type MCB · Zero-point switching</b> Rated operational voltage $U_e$ 24 ... 230 V AC								
	20	24 DC	A	<b>3RF2320-1DA02</b>		1	1 unit	41C
	20	110 ... 230 AC	B	<b>3RF2320-1DA22</b>		1	1 unit	41C
<b>Short-circuit proof with B-type MCB · Zero-point switching</b> Rated operational voltage $U_e$ 48 ... 460 V AC								
	20	24 DC	A	<b>3RF2320-1DA04</b>		1	1 unit	41C
	20	110 ... 230 AC	B	<b>3RF2320-1DA24</b>		1	1 unit	41C
	20	4 ... 30 DC	A	<b>3RF2320-1DA44</b>		1	1 unit	41C
	30		A	<b>3RF2330-1DA44</b>		1	1 unit	41C

3RF2340-1

3RF2320-1

3RF2320-1

⚙ Online configurator see [www.siemens.com/sirius/configurators](http://www.siemens.com/sirius/configurators)

<sup>1)</sup> The type current provides information about the performance of the solid-state contactor. The actual permitted rated operational current  $I_e$  can be smaller depending on the connection method and start-up conditions. For derating characteristic curves see page 6/70, "More Information".



<sup>2)</sup> See page 6/84.

Other rated control supply voltages on request.

# Solid-State Switching Devices for Resistive Loads

## Solid-State Contactors

### SIRIUS 3RF23 solid-state contactors, single-phase

Type current <sup>1)</sup> $I_{max}$	Operational current $I_e/AC-15^{(2)}$	Rated control supply voltage $U_s$	DT	Screw terminals		PU (UNIT, SET, M)	PS*	PG
				Configurator	Price per PU			
A	A	V		Article No.				
<b>Instantaneous switching</b> Rated operational voltage $U_e$ 24 ... 230 V AC								
 3RF2310-1	10.5	6	24 DC	A	3RF2310-1BA02	1	1 unit	41C
	20	12		A	3RF2320-1BA02	1	1 unit	41C
	30	15		B	3RF2330-1BA02	1	1 unit	41C
	40	20		B	3RF2340-1BA02	1	1 unit	41C
	50	25		B	3RF2350-1BA02	1	1 unit	41C
	50	27.5		B	3RF2370-1BA02	1	1 unit	41C
	50	30		B	3RF2390-1BA02	1	1 unit	41C
	10.5	6	110 ... 230 AC	B	3RF2310-1BA22	1	1 unit	41C
	20	12		B	3RF2320-1BA22	1	1 unit	41C
	30	15		B	3RF2330-1BA22	1	1 unit	41C
	40	20		B	3RF2340-1BA22	1	1 unit	41C
	50	25		B	3RF2350-1BA22	1	1 unit	41C
	50	27.5		B	3RF2370-1BA22	1	1 unit	41C
	50	30		B	3RF2390-1BA22	1	1 unit	41C
<b>Instantaneous switching</b> Rated operational voltage $U_e$ 48 ... 460 V AC								
 3RF2320-1	10.5	6	24 DC	A	3RF2310-1BA04	1	1 unit	41C
	20	12		A	3RF2320-1BA04	1	1 unit	41C
	30	15		A	3RF2330-1BA04	1	1 unit	41C
	40	20		B	3RF2340-1BA04	1	1 unit	41C
	50	25		B	3RF2350-1BA04	1	1 unit	41C
	50	27.5		B	3RF2370-1BA04	1	1 unit	41C
	50	30		B	3RF2390-1BA04	1	1 unit	41C
	10.5	6	110 ... 230 AC	B	3RF2310-1BA24	1	1 unit	41C
	20	12		B	3RF2320-1BA24	1	1 unit	41C
	30	15		B	3RF2330-1BA24	1	1 unit	41C
	40	20		B	3RF2340-1BA24	1	1 unit	41C
	50	25		B	3RF2350-1BA24	1	1 unit	41C
	50	27.5		B	3RF2370-1BA24	1	1 unit	41C
	50	30		B	3RF2390-1BA24	1	1 unit	41C
20	12	4 ... 30 DC	B	3RF2320-1BA44	1	1 unit	41C	
30	15		B	3RF2330-1BA44	1	1 unit	41C	
50	25		B	3RF2350-1BA44	1	1 unit	41C	
<b>Instantaneous switching - Blocking voltage 1 600 V, rated operational voltage <math>U_e</math> 48 ... 600 V AC</b>								
 3RF2340-1	10.5	6	24 DC	B	3RF2310-1BA06	1	1 unit	41C
	20	12		A	3RF2320-1BA06	1	1 unit	41C
	30	15		B	3RF2330-1BA06	1	1 unit	41C
	40	20		B	3RF2340-1BA06	1	1 unit	41C
	50	25		B	3RF2350-1BA06	1	1 unit	41C
	50	27.5		B	3RF2370-1BA06	1	1 unit	41C
	50	30		B	3RF2390-1BA06	1	1 unit	41C
	10.5	6	110 ... 230 AC	B	3RF2310-1BA26	1	1 unit	41C
	20	12		B	3RF2320-1BA26	1	1 unit	41C
	30	15		B	3RF2330-1BA26	1	1 unit	41C
	40	20		B	3RF2340-1BA26	1	1 unit	41C
	50	25		B	3RF2350-1BA26	1	1 unit	41C
	50	27.5		B	3RF2370-1BA26	1	1 unit	41C
	50	30		B	3RF2390-1BA26	1	1 unit	41C

Online configurator see [www.siemens.com/sirius/configurators](http://www.siemens.com/sirius/configurators)

1) The type current provides information about the performance of the solid-state contactor. The actual permitted rated operational current  $I_e$  can be smaller depending on the connection method and start-up conditions. For derating characteristic curves see page 6/70, "More Information".

2) Utilization category AC-15:  
Electromagnetic loads, e.g. valves according to IEC 60947-5-1.  
Parameters: max. 1200 1/h, 50 % ON period, 10-times inrush current for 60 ms.

Other rated control supply voltages on request.

# Solid-State Switching Devices for Resistive Loads

## Solid-State Contactors

### SIRIUS 3RF23 solid-state contactors, single-phase

Type current <sup>1)</sup> $I_{max}$	Rated control supply voltage $U_s$ DT	Spring-type terminals	Configurator	Article No.	Price per PU	PU (UNIT, SET, M)	PS*	PG
A	V							
<b>Zero-point switching</b> Rated operational voltage $U_e$ 24 ... 230 V AC								
10.5	24 DC	B	3RF2310-2AA02			1	1 unit	41C
20		A	3RF2320-2AA02			1	1 unit	41C
10.5	110 ... 230 AC	B	3RF2310-2AA22			1	1 unit	41C
20		B	3RF2320-2AA22			1	1 unit	41C
<b>Zero-point switching</b> Rated operational voltage $U_e$ 48 ... 460 V AC								
10.5	24 DC	A	3RF2310-2AA04			1	1 unit	41C
20		A	3RF2320-2AA04			1	1 unit	41C
10.5	110 ... 230 AC	B	3RF2310-2AA24			1	1 unit	41C
20		B	3RF2320-2AA24			1	1 unit	41C
<b>Zero-point switching · Blocking voltage 1 600 V, rated operational voltage <math>U_e</math> 48 ... 600 V AC</b>								
10.5	24 DC	B	3RF2310-2AA06			1	1 unit	41C
20		A	3RF2320-2AA06			1	1 unit	41C
10.5	110 ... 230 AC	B	3RF2310-2AA26			1	1 unit	41C
20		B	3RF2320-2AA26			1	1 unit	41C
<b>Low noise<sup>2)</sup> · Zero-point switching</b> Rated operational voltage $U_e$ 24 ... 230 V AC								
20	24 DC	B	3RF2320-2CA02			1	1 unit	41C
20	110 ... 230 AC	B	3RF2320-2CA22			1	1 unit	41C
<b>Low Noise<sup>2)</sup> · Zero-point switching</b> Rated operational voltage $U_e$ 48 ... 460 V AC								
20	24 DC	B	3RF2320-2CA04			1	1 unit	41C
20	110 ... 230 AC	B	3RF2320-2CA24			1	1 unit	41C
<b>Short-circuit proof with B-type MCB · Zero-point switching</b> Rated operational voltage $U_e$ 24 ... 230 V AC								
20	110 ... 230 AC	B	3RF2320-2DA22			1	1 unit	41C
<b>Short-circuit proof with B-type MCB · Zero-point switching</b> Rated operational voltage $U_e$ 48 ... 460 V AC								
20	24 DC	B	3RF2320-2DA04			1	1 unit	41C
20	110 ... 230 AC	B	3RF2320-2DA24			1	1 unit	41C

⚙️ Online configurator see [www.siemens.com/sirius/configurators](http://www.siemens.com/sirius/configurators)

1) The type current provides information about the performance of the solid-state contactor. The actual permitted rated operational current  $I_e$  can be smaller depending on the connection method and start-up conditions. For derating characteristic curves see page 6/70, "More Information".



2) See page 6/84.

Other rated control supply voltages on request.

# Solid-State Switching Devices for Resistive Loads

## Solid-State Contactors

### SIRIUS 3RF23 solid-state contactors, single-phase

Type current <sup>1)</sup> $I_{max}$	Rated control supply voltage $U_s$	DT	Ring terminal lug connection	Configurator	PU (UNIT, SET, M)	PS*	PG
A	V		Article No.	Price per PU			
<b>Zero-point switching</b> Rated operational voltage $U_e$ 24 ... 230 V AC							
 3RF2350-3	10.5	24 DC	B	3RF2310-3AA02		1	1 unit 41C
	20		B	3RF2320-3AA02		1	1 unit 41C
	30		B	3RF2330-3AA02		1	1 unit 41C
	40		B	3RF2340-3AA02		1	1 unit 41C
	50		B	3RF2350-3AA02		1	1 unit 41C
	70		A	3RF2370-3AA02		1	1 unit 41C
	88		B	3RF2390-3AA02		1	1 unit 41C
	10.5	110 ... 230 AC	B	3RF2310-3AA22		1	1 unit 41C
	20		B	3RF2320-3AA22		1	1 unit 41C
	30		B	3RF2330-3AA22		1	1 unit 41C
	40		B	3RF2340-3AA22		1	1 unit 41C
	50		B	3RF2350-3AA22		1	1 unit 41C
	70		B	3RF2370-3AA22		1	1 unit 41C
	88		B	3RF2390-3AA22		1	1 unit 41C
<b>Zero-point switching</b> Rated operational voltage $U_e$ 48 ... 460 V AC							
 3RF2330-3, covers optional	10.5	24 DC	B	3RF2310-3AA04		1	1 unit 41C
	20		B	3RF2320-3AA04		1	1 unit 41C
	30		A	3RF2330-3AA04		1	1 unit 41C
	40		B	3RF2340-3AA04		1	1 unit 41C
	50		A	3RF2350-3AA04		1	1 unit 41C
	70		A	3RF2370-3AA04		1	1 unit 41C
	88		A	3RF2390-3AA04		1	1 unit 41C
	10.5	110 ... 230 AC	B	3RF2310-3AA24		1	1 unit 41C
	20		B	3RF2320-3AA24		1	1 unit 41C
	30		B	3RF2330-3AA24		1	1 unit 41C
	40		B	3RF2340-3AA24		1	1 unit 41C
	50		B	3RF2350-3AA24		1	1 unit 41C
	70		B	3RF2370-3AA24		1	1 unit 41C
	88		B	3RF2390-3AA24		1	1 unit 41C
20	4 ... 30 DC	B	3RF2320-3AA44		1	1 unit 41C	
30		B	3RF2330-3AA44		1	1 unit 41C	
50		B	3RF2350-3AA44		1	1 unit 41C	
<b>Zero-point switching</b> Rated operational voltage $U_e$ 48 ... 600 V AC							
40	4 ... 30 DC	B	3RF2340-3AA45		1	1 unit 41C	
70		A	3RF2370-3AA45		1	1 unit 41C	
88		B	3RF2390-3AA45		1	1 unit 41C	
<b>Zero-point switching · Blocking voltage 1 600 V, rated operational voltage <math>U_e</math> 48 ... 600 V AC</b>							
10.5	24 DC	B	3RF2310-3AA06		1	1 unit 41C	
20		B	3RF2320-3AA06		1	1 unit 41C	
30		B	3RF2330-3AA06		1	1 unit 41C	
40		B	3RF2340-3AA06		1	1 unit 41C	
50		B	3RF2350-3AA06		1	1 unit 41C	
70		B	3RF2370-3AA06		1	1 unit 41C	
88		B	3RF2390-3AA06		1	1 unit 41C	
10.5	110 ... 230 AC	B	3RF2310-3AA26		1	1 unit 41C	
20		B	3RF2320-3AA26		1	1 unit 41C	
30		B	3RF2330-3AA26		1	1 unit 41C	
40		B	3RF2340-3AA26		1	1 unit 41C	
50		B	3RF2350-3AA26		1	1 unit 41C	
70		B	3RF2370-3AA26		1	1 unit 41C	
88		B	3RF2390-3AA26		1	1 unit 41C	

Online configurator see [www.siemens.com/sirius/configurators](http://www.siemens.com/sirius/configurators)

<sup>1)</sup> The type current provides information about the performance of the solid-state contactor. The actual permitted rated operational current  $I_e$  can be smaller depending on the connection method and start-up conditions. For derating characteristic curves see page 6/70, "More Information".

Other rated control supply voltages on request.

# Solid-State Switching Devices for Resistive Loads

## Solid-State Contactors

### SIRIUS 3RF23 solid-state contactors, single-phase

Type current <sup>1)</sup> $I_{\text{max}}$	Operational current $I_{\text{e}}/\text{AC-15}^{2)}$	Rated control supply voltage $U_{\text{s}}$	DT	Ring terminal lug connection Configurator	PU (UNIT, SET, M)	PS*	PG
A	A	V		Article No.	Price per PU		
<b>Instantaneous switching</b> Rated operational voltage $U_{\text{e}}$ 24 ... 230 V AC							
70	27.5	24 DC	B	3RF2370-3BA02	1	1 unit	41C
88	30		B	3RF2390-3BA02	1	1 unit	41C
70	27.5	110 ... 230 AC	B	3RF2370-3BA22	1	1 unit	41C
88	30		B	3RF2390-3BA22	1	1 unit	41C
<b>Instantaneous switching</b> Rated operational voltage $U_{\text{e}}$ 48 ... 460 V AC							
70	27.5	24 DC	B	3RF2370-3BA04	1	1 unit	41C
88	30		B	3RF2390-3BA04	1	1 unit	41C
70	27.5	110 ... 230 AC	B	3RF2370-3BA24	1	1 unit	41C
88	30		B	3RF2390-3BA24	1	1 unit	41C
<b>Instantaneous switching · Blocking voltage 1 600 V,</b> rated operational voltage $U_{\text{e}}$ 48 ... 600 V AC							
70	27.5	24 DC	B	3RF2370-3BA06	1	1 unit	41C
88	30		B	3RF2390-3BA06	1	1 unit	41C
70	27.5	110 ... 230 AC	B	3RF2370-3BA26	1	1 unit	41C
88	30		B	3RF2390-3BA26	1	1 unit	41C
<b>Short-circuit proof with B-type MCB · Zero-point switching</b> Rated operational voltage $U_{\text{e}}$ 24 ... 230 V AC							
20	--	24 DC	B	3RF2320-3DA02	1	1 unit	41C
20	--	110 ... 230 AC	B	3RF2320-3DA22	1	1 unit	41C
<b>Short-circuit proof with B-type MCB · Zero-point switching</b> Rated operational voltage $U_{\text{e}}$ 48 ... 460 V AC							
20	--	24 DC	B	3RF2320-3DA04	1	1 unit	41C
20	--	110 ... 230 AC	B	3RF2320-3DA24	1	1 unit	41C

Online configurator see [www.siemens.com/sirius/configurators](http://www.siemens.com/sirius/configurators)

Other rated control supply voltages on request.

<sup>1)</sup> The type current provides information about the performance of the solid-state contactor. The actual permitted rated operational current  $I_{\text{e}}$  can be smaller depending on the connection method and start-up conditions. For derating characteristic curves see page 6/70, "More Information".

<sup>2)</sup> Utilization category AC-15:  
Electromagnetic loads, e.g. valves according to IEC 60947-5-1.  
Parameters: max. 1 200 1/h, 50 % ON period, 10-times inrush current for 60 ms.

Version	DT	Article No.	Price per PU	PU (UNIT, SET, M)	PS*	PG
---------	----	-------------	--------------	----------------------	-----	----

#### Optional accessories



3RA2908-1A

**Screwdrivers**  
for all SIRIUS devices with spring-type terminals  
Length approx. 200 mm, size 3.0 mm x 0.5 mm, titanium gray/black, partially insulated

		<b>Spring-type terminals</b>				
A		3RA2908-1A		1	1 unit	41B



3RF2900-3PA88

**Terminal covers** for 3RF21 solid-state relays and 3RF23 solid-state contactors in ring terminal lug connection  
(After simple adaptation, this terminal cover can also be used for screw terminals).



		<b>Ring terminal lug connection</b>				
A		3RF2900-3PA88		1	10 units	41C

# Solid-State Switching Devices for Resistive Loads

## Solid-State Contactors

### SIRIUS 3RF24 solid-state contactors, three-phase

#### Technical specifications

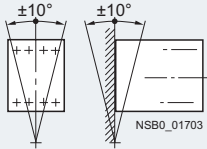
Type	3RF24...-1....	3RF24...-2....	3RF24...-3....
Dimensions (W x H x D)	See page 6/95		
<b>General data</b>			
<b>Ambient temperature</b>			
• During operation, derating from 40 °C	°C	-25 ... +60	
• During storage	°C	-55 ... +80	
<b>Installation altitude</b>	m	0 ... 1000; derating from 1 000	
<b>Shock resistance</b> acc. to IEC 60068-2-27	g/ms	15/11	
<b>Vibration resistance</b> acc. to IEC 60068-2-6	g	2	
<b>Degree of protection</b>	IP20		
<b>Insulation strength</b> at 50/60 Hz (main/control circuit to floor)	V rms	4000	
<b>Electromagnetic compatibility (EMC)</b>			
• Emitted interference according to IEC 60947-4-3			
- Conducted interference voltage	Class A for industrial applications <sup>1)</sup>		
• Interference immunity			
- Electrostatic discharge according to IEC 61000-4-2 (corresponds to degree of severity 3)	kV	Contact discharge 4; air discharge 8; behavior criterion 2	
- Induced RF fields according to IEC 61000-4-6	MHz	0.15 ... 80; 140 dBµV; behavior criterion 1	
- Burst acc. to IEC 61000-4-4	kV	2/5.0 kHz; behavior criterion 2	
- Surge acc. to IEC 61000-4-5	kV	Conductor - ground 2; conductor - conductor 1; behavior criterion 2	
<b>Connection type</b>	 <b>Screw terminals</b>	 <b>Spring-type terminals</b>	 <b>Ring terminal lug connection</b>
<b>Connection, main contacts</b>			
• Conductor cross-section	mm <sup>2</sup>	2 x (1.5 ... 2.5) <sup>2)</sup> , 2 x (2.5 ... 6) <sup>2)</sup>	2 x (0.5 ... 2.5)
- Solid	mm <sup>2</sup>	2 x (1 ... 2.5) <sup>2)</sup> , 2 x (2.5 ... 6) <sup>2)</sup> , 1 x 10	2 x (0.5 ... 1.5)
- Finely stranded with end sleeve	mm <sup>2</sup>	--	--
- Finely stranded without end sleeve	mm <sup>2</sup>	--	2 x (0.5 ... 2.5)
- Solid or stranded, AWG cables	mm <sup>2</sup>	2 x (AWG 14 ... 10)	2 x (AWG 18 ... 14)
• Stripped length	mm	10	10
• Terminal screws	M4	--	M5
- Tightening torque	Nm lb.in	2 ... 2.5 18 ... 22	2 ... 2.5 18 ... 22
• Cable lugs	--	--	--
- According to DIN 46234			5-2.5 ... 5-25
- According to JIS C 2805			R 2-5 ... R 14-5
- Width, maximum	mm		12
<b>Connection, auxiliary/control contacts</b>			
• Conductor cross-section	mm AWG	1 x (0.5 ... 2.5), 2 x (0.5 ... 1.0) AWG 20 ... 12	0.5 ... 2.5 AWG 20 ... 12
• Stripped length	mm	7	10
• Terminal screw	M3	--	M3
- Tightening torque, Ø 3.5, PZ 1	Nm lb.in	0.5 ... 0.6 4.5 ... 5.3	0.5 ... 0.6 4.5 ... 5.3
<b>Grounding screws<sup>3)</sup></b>			
• Size (standard screw)	M4		
<b>Permissible mounting position</b>			

<sup>1)</sup> These products were built as Class A devices. The use of these devices in residential areas could result in lead in radio interference. In this case these may be required to introduce additional interference suppression measures. The versions 3RF24 ...-1AC55 comply with Class B for residential, business and commercial applications.

<sup>2)</sup> If two different conductor cross-sections are connected to one clamping point, both cross-sections must lie in one of the ranges specified.

<sup>3)</sup> The screw is not included in the scope of supply.

# Solid-State Switching Devices for Resistive Loads

## Solid-State Contactors

### SIRIUS 3RF24 solid-state contactors, three-phase

Type	Type current	Rated operational current $I_e$		Power loss at $I_{AC-51}$	Minimum load current	Max. off-state current	Rated peak withstand current $I_{tsm}$	$I^2t$ value
	$I_{AC-51}$ at 40 °C	Acc. to IEC 60947-4-3 at 40 °C	Acc. to UL/CSA at 50 °C					
<b>Main circuit</b>								
<b>3RF2410-AB.5</b>	10.5	7	7	23	0.1	10	200	200
<b>3RF2420-AB.5</b>	22	15	15	44	0.5	10	600	1800
<b>3RF2430-AB.5</b>	30	22	22	61	0.5	10	1200	7200
<b>3RF2440-AB.5</b>	40	30	30	80	0.5	10	1150	6600
<b>3RF2450-AB.5</b>	50	38	38	107	0.5	10	1150	6600
<b>3RF2410-AC.5</b>	10.5	7	7	31	0.5	10	300	450
<b>3RF2420-AC.5</b>	22	15	15	66	0.5	10	600	1800
<b>3RF2430-AC.5</b>	30	22	22	91	0.5	10	1200	7200
<b>3RF2440-AC.5</b>	40	30	30	121	0.5	10	1150	6600
<b>3RF2450-AC.5</b>	50	38	38	160	0.5	10	1150	6600

<sup>1)</sup> The type current provides information about the performance of the solid-state contactor. The actual permitted rated operational current  $I_e$  can be smaller depending on the connection method and start-up conditions.

Type	Type current $I_{AC-51}$	Dimensions (W x H x D) (including heat sink)
	A	mm

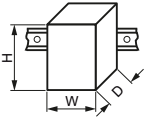

Main circuit		
<b>3RF2410-AB..</b>	10.5	45 x 100 x 105
<b>3RF2410-AC..</b>		
<b>3RF2420-AB..</b>	22	67 x 100 x 112.5
<b>3RF2420-AC..</b>	22	89.5 x 100 x 112.5
<b>3RF2430-AB..</b>	30	

Type	Type current $I_{AC-51}$	Dimensions (W x H x D) (including heat sink)
	A	mm

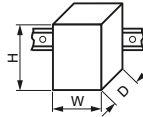

Main circuit		
<b>3RF2430-AC..</b>	30	113.5 x 100 x 121
<b>3RF2440-AB..</b>	40	
<b>3RF2440-AC..</b>	40	157.5 x 100 x 121
<b>3RF2450-AB..</b>	50	
<b>3RF2450-AC..</b>	50	157.5 x 180 x 121

Type	<b>3RF24...-AB.5</b>		<b>3RF24...-AC.5</b>	
<b>Main circuit</b>				
<b>Controlled phases</b>	2-phase		3-phase	
<b>Rated operational voltage <math>U_e</math></b>	V AC	48 ... 600	48 ... 600	
• Operating range	V AC	40 ... 660	40 ... 660	
• Rated frequency	Hz	50/60 ± 10 %	50/60 ± 10 %	
<b>Rated insulation voltage <math>U_i</math></b>	V	600	600	
<b>Rated impulse withstand voltage <math>U_{imp}</math></b>	kV	6	6	
<b>Blocking voltage</b>	V	1200	1200	
<b>Rate of voltage rise</b>	V/μs	1000	1000	

Type	<b>3RF24...-...3.</b>		<b>3RF24...-...4.</b>		<b>3RF24...-...5.</b>	
<b>Control circuit</b>						
<b>Method of operation</b>	AC operation		DC operation		AC operation	
<b>Rated control supply voltage <math>U_s</math></b>	V	110	4 ... 30		190 ... 230	
<b>Rated frequency of the control supply voltage</b>	Hz	50/60 ± 10 %	--		50/60 ± 10 %	
<b>Actuating voltage, max.</b>	V	121	30		253	
<b>Typical actuating current</b>	mA	15	30		15	
<b>Response voltage</b>	V	90	4		180	
<b>Drop-out voltage</b>	V	< 40	< 1		< 40	
<b>Operating times</b>						
• ON-delay	ms	40 + max. one half-wave	1 + max. one half-wave		40 + max. one half-wave	
• OFF-delay	ms	40 + max. one half-wave	1 + max. one half-wave		40 + max. one half-wave	

# Solid-State Switching Devices for Resistive Loads

## Solid-State Contactors

### SIRIUS 3RF24 solid-state contactors, three-phase

#### Circuit diagrams

Two-phase controlled,  
DC control supply voltage

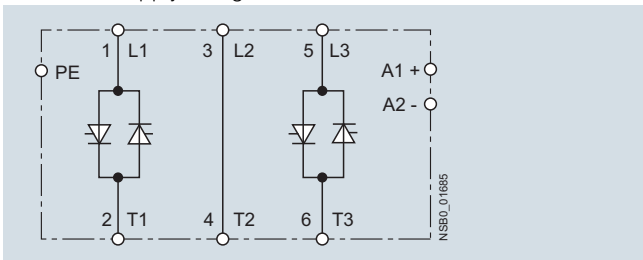

Two-phase controlled,  
AC control supply voltage

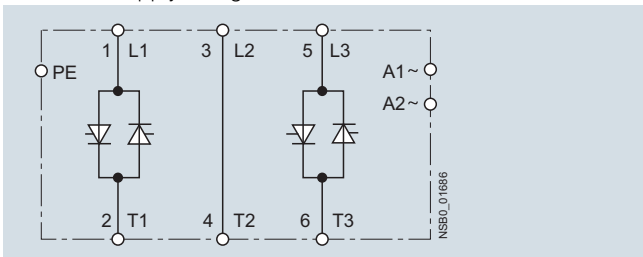

Three-phase controlled,  
DC control supply voltage

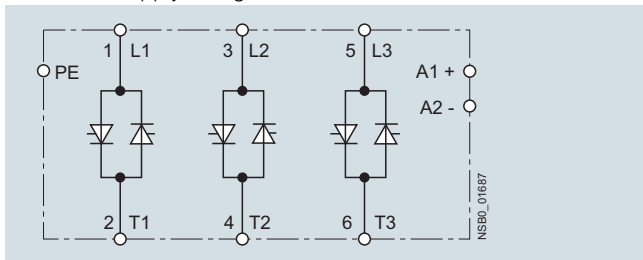

Three-phase controlled,  
AC control supply voltage

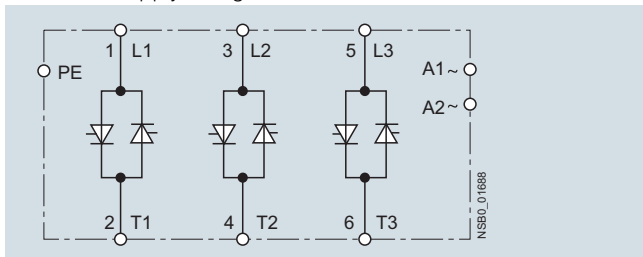

#### Selection and ordering data

Type current <sup>1)</sup> $I_{max}$	Rated control supply voltage $U_c$ DT	Screw terminals	PU (UNIT, SET, M)	PS*	PG
A	V	Configurator	Price per PU		
		Article No.			

#### Zero-point switching Rated operational voltage $U_e$ 48 ... 600 V AC



#### Two-phase controlled

Type current <sup>1)</sup>	Rated operational voltage $U_e$	Terminal	Article No.	PU	PS*	PG
10.5	4 ... 30 DC	A	3RF2410-1AB45	1	1 unit	41C
20		A	3RF2420-1AB45	1	1 unit	41C
30		A	3RF2430-1AB45	1	1 unit	41C
40		B	3RF2440-1AB45	1	1 unit	41C
50		A	3RF2450-1AB45	1	1 unit	41C
10.5	110 AC	B	3RF2410-1AB35	1	1 unit	41C
20		B	3RF2420-1AB35	1	1 unit	41C
30		B	3RF2430-1AB35	1	1 unit	41C
40		B	3RF2440-1AB35	1	1 unit	41C
50		B	3RF2450-1AB35	1	1 unit	41C
10.5	230 AC	B	3RF2410-1AB55	1	1 unit	41C
20		B	3RF2420-1AB55	1	1 unit	41C
30		A	3RF2430-1AB55	1	1 unit	41C
40		B	3RF2440-1AB55	1	1 unit	41C
50		B	3RF2450-1AB55	1	1 unit	41C



#### Three-phase controlled

Type current <sup>1)</sup>	Rated operational voltage $U_e$	Terminal	Article No.	PU	PS*	PG
10.5	4 ... 30 DC	A	3RF2410-1AC45	1	1 unit	41C
20		A	3RF2420-1AC45	1	1 unit	41C
30		A	3RF2430-1AC45	1	1 unit	41C
40		A	3RF2440-1AC45	1	1 unit	41C
50		A	3RF2450-1AC45	1	1 unit	41C
10.5	110 AC	B	3RF2410-1AC35	1	1 unit	41C
20		B	3RF2420-1AC35	1	1 unit	41C
30		B	3RF2430-1AC35	1	1 unit	41C
40		B	3RF2440-1AC35	1	1 unit	41C
50		B	3RF2450-1AC35	1	1 unit	41C
10.5	230 AC	B	3RF2410-1AC55	1	1 unit	41C
20		B	3RF2420-1AC55	1	1 unit	41C
30		B	3RF2430-1AC55	1	1 unit	41C
40		B	3RF2440-1AC55	1	1 unit	41C
50		B	3RF2450-1AC55	1	1 unit	41C

Online configurator [see www.siemens.com/sirius/configurators](http://www.siemens.com/sirius/configurators)

<sup>1)</sup> The type current provides information about the performance of the solid-state contactor. The actual permitted rated operational current  $I_o$  can be smaller depending on the connection method and start-up conditions. For derating characteristic curves [see page 6/70, "More Information"](#).



# Solid-State Switching Devices for Resistive Loads

## Solid-State Contactors

### SIRIUS 3RF24 solid-state contactors, three-phase

Type current <sup>1)</sup> $I_{max}$	Rated control supply voltage $U_s$ DT	Spring-type terminals	⊕	PU (UNIT, SET, M)	PS*	PG
A	V	Configurator	⚙️			
		Article No.		Price per PU		

#### Zero-point switching Rated operational voltage $U_e$ 48 ... 600 V AC



3RF2410-2AB45

<b>Two-phase controlled</b>						
10	4 ... 30 DC	B	<b>3RF2410-2AB45</b>	1	1 unit	41C
20		B	<b>3RF2420-2AB45</b>	1	1 unit	41C
10	230 AC	B	<b>3RF2410-2AB55</b>	1	1 unit	41C
20		B	<b>3RF2420-2AB55</b>	1	1 unit	41C
<b>Three-phase controlled</b>						
10	4 ... 30 DC	B	<b>3RF2410-2AC45</b>	1	1 unit	41C
20		B	<b>3RF2420-2AC45</b>	1	1 unit	41C
10	230 AC	B	<b>3RF2410-2AC55</b>	1	1 unit	41C
20		B	<b>3RF2420-2AC55</b>	1	1 unit	41C

Type current <sup>1)</sup> $I_{max}$	Rated control supply voltage $U_s$ DT	Ring terminal lug connection	⊕	PU (UNIT, SET, M)	PS*	PG
A	V	Configurator	⚙️			
		Article No.		Price per PU		

#### Zero-point switching Rated operational voltage $U_e$ 48 ... 600 V AC

<b>Two-phase controlled</b>						
50	4 ... 30 DC	B	<b>3RF2450-3AB45</b>	1	1 unit	41C
50	230 AC	B	<b>3RF2450-3AB55</b>	1	1 unit	41C
<b>Three-phase controlled</b>						
50	4 ... 30 DC	B	<b>3RF2450-3AC45</b>	1	1 unit	41C
50	230 AC	B	<b>3RF2450-3AC55</b>	1	1 unit	41C

⚙️ Online configurator see [www.siemens.com/sirius/configurators](http://www.siemens.com/sirius/configurators)

<sup>1)</sup> The type current provides information about the performance of the solid-state contactor. The actual permitted rated operational current  $I_e$  can be smaller depending on the connection method and start-up conditions. For derating characteristic curves see page 6/70, "More Information".

# Solid-State Switching Devices for Resistive Loads

## 3RF29 Function Modules

### General data

#### Overview

##### Function modules for SIRIUS 3RF2 solid-state switching devices

A great variety of applications demand an expanded range of functionality. With our function modules, these requirements can be met really easily. The modules are mounted simply by clicking them into place; straight away the necessary connections are made with the solid-state relay or contactor.

The plug-in connection to control the solid-state switching devices can simply remain in use. The external connections have screw terminals.

The following function modules are available:

- Converters
- Load monitoring
- Heating current monitoring
- Power controllers
- Power regulators

With the exception of the converter, the function modules can be used only with single-phase solid-state switching devices.

##### Recommended assignment of the function modules to the 3RF21 single-phase solid-state relays

Type	Accessories					
	Converters	Load monitoring Basic	Extended <sup>1)</sup>	Heating current monitoring <sup>1)</sup>	Power controllers <sup>1)</sup>	Power regulators <sup>1)</sup>
<b>Type current = 20 A</b>						
<b>3RF2120-1A.02</b>	3RF2900-0EA18	3RF2920-0FA08	3RF2920-0GA13	--	3RF2920-0KA13	3RF2920-0HA13
<b>3RF2120-1A.04</b>	3RF2900-0EA18	3RF2920-0FA08	3RF2920-0GA16	3RF2932-0JA16	3RF2920-0KA16	3RF2920-0HA16
<b>3RF2120-1A.22</b>	--	--	3RF2920-0GA33	--	--	--
<b>3RF2120-1A.24</b>	--	--	3RF2920-0GA36	--	--	--
<b>3RF2120-1A.42</b>	3RF2900-0EA18	3RF2920-0FA08	3RF2920-0GA13	--	3RF2920-0KA13	3RF2920-0HA13
<b>3RF2120-1A.45</b>	3RF2900-0EA18	3RF2920-0FA08	3RF2920-0GA16	3RF2932-0JA16	3RF2920-0KA16	3RF2920-0HA16
<b>3RF2120-1B.04</b>	3RF2900-0EA18	3RF2920-0FA08	3RF2920-0GA16	3RF2932-0JA16	3RF2920-0KA16	3RF2920-0HA16
<b>3RF2120-2A.02</b>	3RF2900-0EA18	--	--	--	--	--
<b>3RF2120-2A.04</b>	3RF2900-0EA18	--	--	--	--	--
<b>3RF2120-2A.22</b>	--	--	--	--	--	--
<b>3RF2120-2A.24</b>	--	--	--	--	--	--
<b>3RF2120-2A.42</b>	3RF2900-0EA18	--	--	--	--	--
<b>3RF2120-2A.45</b>	3RF2900-0EA18	--	--	--	--	--
<b>3RF2120-3A.02</b>	3RF2900-0EA18	--	3RF2920-0GA13	--	3RF2920-0KA13	3RF2920-0HA13
<b>3RF2120-3A.04</b>	3RF2900-0EA18	--	3RF2920-0GA16	3RF2932-0JA16	3RF2920-0KA16	3RF2920-0HA16
<b>3RF2120-3A.22</b>	--	--	3RF2920-0GA33	--	3RF2920-0KA13	3RF2920-0HA13
<b>3RF2120-3A.24</b>	--	--	3RF2920-0GA36	--	3RF2920-0KA16	3RF2920-0HA16
<b>Type current = 30 A</b>						
<b>3RF2130-1A.02</b>	3RF2900-0EA18	3RF2920-0FA08	3RF2950-0GA13	--	3RF2950-0KA13	3RF2950-0HA13
<b>3RF2130-1A.04</b>	3RF2900-0EA18	3RF2920-0FA08	3RF2950-0GA16	3RF2932-0JA16	3RF2950-0KA16	3RF2950-0HA16
<b>3RF2130-1A.06</b>	3RF2900-0EA18	3RF2920-0FA08	3RF2950-0GA16	3RF2932-0JA16	3RF2950-0KA16	3RF2950-0HA16
<b>3RF2130-1A.22</b>	--	--	3RF2950-0GA33	--	--	3RF2950-0HA33
<b>3RF2130-1A.24</b>	--	--	3RF2950-0GA36	--	--	3RF2950-0HA36
<b>3RF2130-1A.26</b>	--	--	3RF2950-0GA36	--	--	3RF2950-0HA36
<b>3RF2130-1A.42</b>	3RF2900-0EA18	3RF2920-0FA08	3RF2950-0GA13	--	3RF2950-0KA13	3RF2950-0HA13
<b>3RF2130-1A.45</b>	3RF2900-0EA18	3RF2920-0FA08	3RF2950-0GA16	3RF2932-0JA16	3RF2950-0KA16	3RF2950-0HA16
<b>3RF2130-1B.04</b>	3RF2900-0EA18	3RF2920-0FA08	3RF2950-0GA16	3RF2932-0JA16	3RF2950-0KA16	3RF2950-0HA16
<b>Type current = 50 A</b>						
<b>3RF2150-1A.02</b>	3RF2900-0EA18	3RF2920-0FA08	3RF2950-0GA13	--	3RF2950-0KA13	3RF2950-0HA13
<b>3RF2150-1A.04</b>	3RF2900-0EA18	3RF2920-0FA08	3RF2950-0GA16	3RF2932-0JA16	3RF2950-0KA16	3RF2950-0HA16
<b>3RF2150-1A.06</b>	3RF2900-0EA18	3RF2920-0FA08	3RF2950-0GA16	3RF2932-0JA16	3RF2950-0KA16	3RF2950-0HA16
<b>3RF2150-1A.22</b>	--	--	3RF2950-0GA33	--	--	3RF2950-0HA33
<b>3RF2150-1A.24</b>	--	--	3RF2950-0GA36	--	--	3RF2950-0HA36
<b>3RF2150-1A.26</b>	--	--	3RF2950-0GA36	--	--	3RF2950-0HA36
<b>3RF2150-1A.45</b>	3RF2900-0EA18	3RF2920-0FA08	3RF2950-0GA16	3RF2932-0JA16	3RF2950-0KA16	3RF2950-0HA16
<b>3RF2150-1B.04</b>	3RF2900-0EA18	3RF2920-0FA08	3RF2950-0GA16	3RF2932-0JA16	3RF2950-0KA16	3RF2950-0HA16
<b>3RF2150-1B.06</b>	3RF2900-0EA18	3RF2920-0FA08	3RF2950-0GA16	3RF2932-0JA16	3RF2950-0KA16	3RF2950-0HA16
<b>3RF2150-1B.22</b>	--	--	3RF2950-0GA33	--	--	3RF2950-0HA33
<b>3RF2150-2A.02</b>	3RF2900-0EA18	--	--	--	--	--
<b>3RF2150-2A.04</b>	3RF2900-0EA18	--	--	--	--	--
<b>3RF2150-2A.06</b>	3RF2900-0EA18	--	--	--	--	--
<b>3RF2150-2A.14</b>	3RF2900-0EA18	--	--	--	--	--
<b>3RF2150-2A.22</b>	--	--	--	--	--	--
<b>3RF2150-2A.24</b>	--	--	--	--	--	--
<b>3RF2150-2A.26</b>	--	--	--	--	--	--
<b>3RF2150-3A.02</b>	3RF2900-0EA18	--	3RF2950-0GA13	--	3RF2950-0KA13	3RF2950-0HA13
<b>3RF2150-3A.04</b>	3RF2900-0EA18	--	3RF2950-0GA16	3RF2932-0JA16	3RF2950-0KA16	3RF2950-0HA16
<b>3RF2150-3A.06</b>	3RF2900-0EA18	--	3RF2950-0GA16	3RF2932-0JA16	3RF2950-0KA16	3RF2950-0HA16
<b>3RF2150-3A.22</b>	--	--	3RF2950-0GA33	--	--	3RF2950-0HA33
<b>3RF2150-3A.24</b>	--	--	3RF2950-0GA36	--	--	3RF2950-0HA36
<b>3RF2150-3A.26</b>	--	--	3RF2950-0GA36	--	--	3RF2950-0HA36

<sup>1)</sup> For line voltages in the range from 110 to 230 V, the versions of the 3RF29 ...-0.A13 function modules can also be combined with more voltage-resistant versions of the solid-state relays (3RF21 ...-....4 , ...-....5 or ...-....6).

# Solid-State Switching Devices for Resistive Loads

## 3RF29 Function Modules

### General data

Type	Accessories					
	Converters	Load monitoring		Heating current monitoring <sup>1)</sup>	Power controllers <sup>1)</sup>	Power regulators <sup>1)</sup>
		Basic	Extended <sup>1)</sup>			
<b>Type current = 70 A</b>						
<b>3RF2170-1A.02</b>	3RF2900-0EA18	3RF2920-0FA08	3RF2950-0GA13	--	3RF2950-0KA13	3RF2950-0HA13
<b>3RF2170-1A.04</b>	3RF2900-0EA18	3RF2920-0FA08	3RF2950-0GA16	3RF2932-0JA16	3RF2950-0KA16	3RF2950-0HA16
<b>3RF2170-1A.05</b>	3RF2900-0EA18	3RF2920-0FA08	3RF2950-0GA16	3RF2932-0JA16	3RF2950-0KA16	3RF2950-0HA16
<b>3RF2170-1A.06</b>	3RF2900-0EA18	3RF2920-0FA08	3RF2950-0GA16	3RF2932-0JA16	3RF2950-0KA16	3RF2950-0HA16
<b>3RF2170-1A.22</b>	--	--	3RF2950-0GA33	--	--	3RF2950-0HA33
<b>3RF2170-1A.24</b>	--	--	3RF2950-0GA36	--	--	3RF2950-0HA36
<b>3RF2170-1A.26</b>	--	--	3RF2950-0GA36	--	--	3RF2950-0HA36
<b>3RF2170-1A.45</b>	3RF2900-0EA18	3RF2920-0FA08	3RF2950-0GA16	3RF2932-0JA16	3RF2950-0KA16	3RF2950-0HA16
<b>3RF2170-1B.04</b>	3RF2900-0EA18	3RF2920-0FA08	3RF2950-0GA16	3RF2932-0JA16	3RF2950-0KA16	3RF2950-0HA16
<b>3RF2170-1C.04</b>	3RF2900-0EA18	3RF2920-0FA08	3RF2950-0GA16	3RF2932-0JA16	3RF2950-0KA16	3RF2950-0HA16
<b>Type current = 90 A</b>						
<b>3RF2190-1A.02</b>	3RF2900-0EA18	3RF2920-0FA08	3RF2950-0GA13	--	3RF2950-0KA13	3RF2950-0HA13
<b>3RF2190-1A.04</b>	3RF2900-0EA18	3RF2920-0FA08	3RF2950-0GA16	3RF2932-0JA16	3RF2950-0KA16	3RF2950-0HA16
<b>3RF2190-1A.06</b>	3RF2900-0EA18	3RF2920-0FA08	3RF2950-0GA16	3RF2932-0JA16	3RF2950-0KA16	3RF2950-0HA16
<b>3RF2190-1A.22</b>	--	--	3RF2950-0GA33	--	--	3RF2950-0HA33
<b>3RF2190-1A.24</b>	--	--	3RF2950-0GA36	--	--	3RF2950-0HA36
<b>3RF2190-1A.26</b>	--	--	3RF2950-0GA36	--	--	3RF2950-0HA36
<b>3RF2190-1A.45</b>	3RF2900-0EA18	3RF2920-0FA08	3RF2950-0GA16	3RF2932-0JA16	3RF2950-0KA16	3RF2950-0HA16
<b>3RF2190-1B.04</b>	3RF2900-0EA18	3RF2920-0FA08	3RF2950-0GA16	3RF2932-0JA16	3RF2950-0KA16	3RF2950-0HA16
<b>3RF2190-2A.02</b>	3RF2900-0EA18	--	--	--	--	--
<b>3RF2190-2A.04</b>	3RF2900-0EA18	--	--	--	--	--
<b>3RF2190-2A.06</b>	3RF2900-0EA18	--	--	--	--	--
<b>3RF2190-2A.22</b>	--	--	--	--	--	--
<b>3RF2190-2A.24</b>	--	--	--	--	--	--
<b>3RF2190-2A.26</b>	--	--	--	--	--	--
<b>3RF2190-3A.02</b>	3RF2900-0EA18	--	3RF2990-0GA13	--	3RF2990-0KA13	3RF2990-0HA13
<b>3RF2190-3A.04</b>	3RF2900-0EA18	--	3RF2990-0GA16	3RF2932-0JA16	3RF2990-0KA16	3RF2990-0HA16
<b>3RF2190-3A.06</b>	3RF2900-0EA18	--	3RF2990-0GA16	3RF2932-0JA16	3RF2990-0KA16	3RF2990-0HA16
<b>3RF2190-3A.22</b>	--	--	3RF2990-0GA33	--	--	3RF2990-0HA33
<b>3RF2190-3A.24</b>	--	--	3RF2990-0GA36	--	--	3RF2990-0HA36
<b>3RF2190-3A.26</b>	--	--	3RF2990-0GA36	--	--	3RF2990-0HA36
<b>3RF2190-3A.44</b>	3RF2900-0EA18	--	3RF2990-0GA16	3RF2932-0JA16	3RF2990-0KA16	3RF2990-0HA16

<sup>1)</sup> For line voltages in the range from 110 to 230 V, the versions of the 3RF29 ...-0.A13 function modules can also be combined with more voltage-resistant versions of the solid-state relays (3RF21 ...-...4 , ...-...5 or ...-...6).

#### Recommended assignment of the function modules to the 3RF22 three-phase solid-state relays

Type	Accessories					
	Converters	Load monitoring		Heating current monitoring	Power controllers	Power regulators
		Basic	Extended			
<b>Type current up to 55 A</b>						
<b>3RF22...-1AA..</b>	3RF2900-0EA18	--	--	--	--	--
<b>3RF22...-2AA..</b>	3RF2900-0EA18	--	--	--	--	--
<b>3RF22...-3AA..</b>	3RF2900-0EA18	--	--	--	--	--

#### Recommended assignment of the function modules to the 3RF23 single-phase solid-state contactors

Type	Accessories					
	Converters	Load monitoring		Heating current monitoring <sup>1)</sup>	Power controllers <sup>1)</sup>	Power regulators <sup>1)</sup>
		Basic	Extended <sup>1)</sup>			
<b>Type current <math>I_e = 10.5</math> A</b>						
<b>3RF2310-1A.02</b>	3RF2900-0EA18	3RF2920-0FA08	3RF2920-0GA13	3RF2916-0JA13	3RF2920-0KA13	3RF2920-0HA13
<b>3RF2310-1A.04</b>	3RF2900-0EA18	3RF2920-0FA08	3RF2920-0GA16	3RF2932-0JA16	3RF2920-0KA16	3RF2920-0HA16
<b>3RF2310-1A.06</b>	3RF2900-0EA18	3RF2920-0FA08	3RF2920-0GA16	3RF2932-0JA16	3RF2920-0KA16	3RF2920-0HA16
<b>3RF2310-1A.12</b>	3RF2900-0EA18	--	3RF2920-0GA13	3RF2916-0JA13	3RF2920-0KA13	3RF2920-0HA13
<b>3RF2310-1A.14</b>	3RF2900-0EA18	--	3RF2920-0GA16	3RF2932-0JA16	3RF2920-0KA16	3RF2920-0HA16
<b>3RF2310-1A.22</b>	--	--	3RF2920-0GA33	--	--	3RF2920-0HA33
<b>3RF2310-1A.24</b>	--	--	3RF2920-0GA36	--	--	3RF2920-0HA36
<b>3RF2310-1A.26</b>	--	--	3RF2920-0GA36	--	--	3RF2920-0HA36
<b>3RF2310-1A.44</b>	3RF2900-0EA18	3RF2920-0FA08	3RF2920-0GA16	3RF2932-0JA16	3RF2920-0KA16	3RF2920-0HA16
<b>3RF2310-1A.45</b>	3RF2900-0EA18	3RF2920-0FA08	3RF2920-0GA16	3RF2932-0JA16	3RF2920-0KA16	3RF2920-0HA16

<sup>1)</sup> For line voltages in the range from 110 to 230 V, the versions of the 3RF29 ...-0.A13 function modules can also be combined with more voltage-resistant versions of the solid-state contactors (3RF23 ...-...4 , ...-...5 or ...-...6).

# Solid-State Switching Devices for Resistive Loads

## 3RF29 Function Modules

### General data

Type	Accessories					
	Converters	Load monitoring Basic	Extended <sup>1)</sup>	Heating current monitoring <sup>1)</sup>	Power controllers <sup>1)</sup>	Power regulators <sup>1)</sup>
<b>Type current <math>I_e = 10.5\text{ A}</math></b>						
<b>3RF2310-1B.02</b>	3RF2900-0EA18	3RF2920-0FA08	3RF2920-0GA13	3RF2916-0JA13	3RF2920-0KA13	3RF2920-0HA13
<b>3RF2310-1B.04</b>	3RF2900-0EA18	3RF2920-0FA08	3RF2920-0GA16	3RF2932-0JA16	3RF2920-0KA16	3RF2920-0HA16
<b>3RF2310-1B.06</b>	3RF2900-0EA18	3RF2920-0FA08	3RF2920-0GA16	3RF2932-0JA16	3RF2920-0KA16	3RF2920-0HA16
<b>3RF2310-1B.22</b>	--	--	3RF2920-0GA33	--	--	3RF2920-0HA33
<b>3RF2310-1B.24</b>	--	--	3RF2920-0GA36	--	--	3RF2920-0HA36
<b>3RF2310-1B.26</b>	--	--	3RF2920-0GA36	--	--	3RF2920-0HA36
<b>3RF2310-2A.02</b>	3RF2900-0EA18	--	--	--	--	--
<b>3RF2310-2A.04</b>	3RF2900-0EA18	--	--	--	--	--
<b>3RF2310-2A.06</b>	3RF2900-0EA18	--	--	--	--	--
<b>3RF2310-2A.22</b>	--	--	--	--	--	--
<b>3RF2310-2A.24</b>	--	--	--	--	--	--
<b>3RF2310-2A.26</b>	--	--	--	--	--	--
<b>3RF2310-3A.02</b>	3RF2900-0EA18	--	3RF2920-0GA13	3RF2916-0JA13	3RF2920-0KA13	3RF2920-0HA13
<b>3RF2310-3A.04</b>	3RF2900-0EA18	--	3RF2920-0GA16	3RF2932-0JA16	3RF2920-0KA16	3RF2920-0HA16
<b>3RF2310-3A.06</b>	3RF2900-0EA18	--	3RF2920-0GA16	3RF2932-0JA16	3RF2920-0KA16	3RF2920-0HA16
<b>3RF2310-3A.22</b>	--	--	3RF2920-0GA33	--	--	3RF2920-0HA33
<b>3RF2310-3A.24</b>	--	--	3RF2920-0GA36	--	--	3RF2920-0HA36
<b>3RF2310-3A.26</b>	--	--	3RF2920-0GA36	--	--	3RF2920-0HA36
<b>Type current <math>I_e = 20\text{ A}</math></b>						
<b>3RF2320-1A.02</b>	3RF2900-0EA18	3RF2920-0FA08	3RF2920-0GA13	--	3RF2920-0KA13	3RF2920-0HA13
<b>3RF2320-1A.04</b>	3RF2900-0EA18	3RF2920-0FA08	3RF2920-0GA16	3RF2932-0JA16	3RF2920-0KA16	3RF2920-0HA16
<b>3RF2320-1A.06</b>	3RF2900-0EA18	3RF2920-0FA08	3RF2920-0GA16	3RF2932-0JA16	3RF2920-0KA16	3RF2920-0HA16
<b>3RF2320-1A.14</b>	3RF2900-0EA18	--	3RF2920-0GA16	--	3RF2920-0KA16	3RF2920-0HA16
<b>3RF2320-1A.22</b>	--	--	3RF2920-0GA33	--	--	3RF2920-0HA33
<b>3RF2320-1A.24</b>	--	--	3RF2920-0GA36	--	--	3RF2920-0HA36
<b>3RF2320-1A.26</b>	--	--	3RF2920-0GA36	--	--	3RF2920-0HA36
<b>3RF2320-1A.44</b>	3RF2900-0EA18	3RF2920-0FA08	3RF2920-0GA16	3RF2932-0JA16	3RF2920-0KA16	3RF2920-0HA16
<b>3RF2320-1A.45</b>	3RF2900-0EA18	3RF2920-0FA08	3RF2920-0GA16	3RF2932-0JA16	3RF2920-0KA16	3RF2920-0HA16
<b>3RF2320-1B.02</b>	3RF2900-0EA18	3RF2920-0FA08	3RF2920-0GA13	--	3RF2920-0KA13	3RF2920-0HA13
<b>3RF2320-1B.04</b>	3RF2900-0EA18	3RF2920-0FA08	3RF2920-0GA16	3RF2932-0JA16	3RF2920-0KA16	3RF2920-0HA16
<b>3RF2320-1B.06</b>	3RF2900-0EA18	3RF2920-0FA08	3RF2920-0GA16	3RF2932-0JA16	3RF2920-0KA16	3RF2920-0HA16
<b>3RF2320-1B.22</b>	--	--	3RF2920-0GA33	--	--	3RF2920-0HA33
<b>3RF2320-1B.24</b>	--	--	3RF2920-0GA36	--	--	3RF2920-0HA36
<b>3RF2320-1B.26</b>	--	--	3RF2920-0GA36	--	--	3RF2920-0HA36
<b>3RF2320-1B.44</b>	3RF2900-0EA18	3RF2920-0FA08	3RF2920-0GA16	3RF2932-0JA16	3RF2920-0KA16	3RF2920-0HA16
<b>3RF2320-1C.02</b>	3RF2900-0EA18	3RF2920-0FA08	3RF2920-0GA13	--	3RF2920-0KA13	3RF2920-0HA13
<b>3RF2320-1C.04</b>	3RF2900-0EA18	3RF2920-0FA08	3RF2920-0GA16	3RF2932-0JA16	3RF2920-0KA16	3RF2920-0HA16
<b>3RF2320-1C.22</b>	--	--	3RF2920-0GA33	--	--	3RF2920-0HA33
<b>3RF2320-1C.24</b>	--	--	3RF2920-0GA36	--	--	3RF2920-0HA36
<b>3RF2320-1C.44</b>	3RF2900-0EA18	3RF2920-0FA08	3RF2920-0GA16	3RF2932-0JA16	3RF2920-0KA16	3RF2920-0HA16
<b>3RF2320-1D.02</b>	3RF2900-0EA18	3RF2920-0FA08	3RF2920-0GA13	--	3RF2920-0KA13	3RF2920-0HA13
<b>3RF2320-1D.04</b>	3RF2900-0EA18	3RF2920-0FA08	3RF2920-0GA16	3RF2932-0JA16	3RF2920-0KA16	3RF2920-0HA16
<b>3RF2320-1D.22</b>	--	--	3RF2920-0GA33	--	--	3RF2920-0HA33
<b>3RF2320-1D.24</b>	--	--	3RF2920-0GA36	--	--	3RF2920-0HA36
<b>3RF2320-1D.44</b>	3RF2900-0EA18	3RF2920-0FA08	3RF2920-0GA16	3RF2932-0JA16	3RF2920-0KA16	3RF2920-0HA16
<b>3RF2320-2A.02</b>	3RF2900-0EA18	--	--	--	--	--
<b>3RF2320-2A.04</b>	3RF2900-0EA18	--	--	--	--	--
<b>3RF2320-2A.06</b>	3RF2900-0EA18	--	--	--	--	--
<b>3RF2320-2A.22</b>	--	--	--	--	--	--
<b>3RF2320-2A.24</b>	--	--	--	--	--	--
<b>3RF2320-2A.26</b>	--	--	--	--	--	--
<b>3RF2320-2C.02</b>	3RF2900-0EA18	--	--	--	--	--
<b>3RF2320-2C.04</b>	3RF2900-0EA18	--	--	--	--	--
<b>3RF2320-2C.22</b>	--	--	--	--	--	--
<b>3RF2320-2C.24</b>	--	--	--	--	--	--
<b>3RF2320-2D.22</b>	--	--	--	--	--	--
<b>3RF2320-2D.24</b>	--	--	--	--	--	--
<b>3RF2320-3A.02</b>	3RF2900-0EA18	--	3RF2920-0GA13	--	3RF2920-0KA13	3RF2920-0HA13
<b>3RF2320-3A.04</b>	3RF2900-0EA18	--	3RF2920-0GA16	3RF2932-0JA16	3RF2920-0KA16	3RF2920-0HA16
<b>3RF2320-3A.06</b>	3RF2900-0EA18	--	3RF2920-0GA16	3RF2932-0JA16	3RF2920-0KA16	3RF2920-0HA16
<b>3RF2320-3A.22</b>	--	--	3RF2920-0GA33	--	--	3RF2920-0HA33
<b>3RF2320-3A.24</b>	--	--	3RF2920-0GA36	--	--	3RF2920-0HA36
<b>3RF2320-3A.26</b>	--	--	3RF2920-0GA36	--	--	3RF2920-0HA36
<b>3RF2320-3A.44</b>	3RF2900-0EA18	--	3RF2920-0GA16	3RF2932-0JA16	3RF2920-0KA16	3RF2920-0HA16

<sup>1)</sup> For line voltages in the range from 110 to 230 V, the versions of the 3RF29 ...0.A13 function modules can also be combined with more voltage-resistant versions of the solid-state contactors (3RF23 ...4, ...5 or ...6).

# Solid-State Switching Devices for Resistive Loads

## 3RF29 Function Modules

### General data

Type	Accessories						
	Converters	Load monitoring Basic <sup>1)</sup>		Extended <sup>2)</sup>	Heating current monitoring <sup>2)</sup>	Power controllers <sup>2)</sup>	Power regulators <sup>2)</sup>
<b>Type current <math>I_e = 20</math> A</b>							
<b>3RF2320-3D.02</b>	3RF2900-0EA18	--		3RF2920-0GA13	--	3RF2920-0KA13	3RF2920-0HA13
<b>3RF2320-3D.04</b>	3RF2900-0EA18	--		3RF2920-0GA16	3RF2932-0JA16	3RF2920-0KA16	3RF2920-0HA16
<b>3RF2320-3D.22</b>	--	--		3RF2920-0GA33	--	--	3RF2920-0HA33
<b>3RF2320-3D.24</b>	--	--		3RF2920-0GA36	--	--	3RF2920-0HA36
<b>Type current <math>I_e = 30</math> A</b>							
<b>3RF2330-1A.02</b>	3RF2900-0EA18	--		3RF2950-0GA13	--	3RF2950-0KA13	3RF2950-0HA13
<b>3RF2330-1A.04</b>	3RF2900-0EA18	--		3RF2950-0GA16	3RF2932-0JA16	3RF2950-0KA16	3RF2950-0HA16
<b>3RF2330-1A.06</b>	3RF2900-0EA18	--		3RF2950-0GA16	3RF2932-0JA16	3RF2950-0KA16	3RF2950-0HA16
<b>3RF2330-1A.14</b>	3RF2900-0EA18	--		3RF2950-0GA16	3RF2932-0JA16	3RF2950-0KA16	3RF2950-0HA16
<b>3RF2330-1A.22</b>	--	--		3RF2950-0GA33	--	--	3RF2950-0HA33
<b>3RF2330-1A.24</b>	--	--		3RF2950-0GA36	--	--	3RF2950-0HA36
<b>3RF2330-1A.25</b>	--	--		3RF2950-0GA36	--	--	3RF2950-0HA36
<b>3RF2330-1A.26</b>	--	--		3RF2950-0GA36	--	--	3RF2950-0HA36
<b>3RF2330-1A.44</b>	3RF2900-0EA18	--		3RF2950-0GA16	3RF2932-0JA16	3RF2950-0KA16	3RF2950-0HA16
<b>3RF2330-1A.45</b>	3RF2900-0EA18	--		3RF2950-0GA16	3RF2932-0JA16	3RF2950-0KA16	3RF2950-0HA16
<b>3RF2330-1B.02</b>	3RF2900-0EA18	--		3RF2950-0GA13	--	3RF2950-0KA13	3RF2950-0HA13
<b>3RF2330-1B.04</b>	3RF2900-0EA18	--		3RF2950-0GA16	3RF2932-0JA16	3RF2950-0KA16	3RF2950-0HA16
<b>3RF2330-1B.06</b>	3RF2900-0EA18	--		3RF2950-0GA16	3RF2932-0JA16	3RF2950-0KA16	3RF2950-0HA16
<b>3RF2330-1B.22</b>	--	--		3RF2950-0GA33	--	--	3RF2950-0HA33
<b>3RF2330-1B.24</b>	--	--		3RF2950-0GA36	--	--	3RF2950-0HA36
<b>3RF2330-1B.26</b>	--	--		3RF2950-0GA36	--	--	3RF2950-0HA36
<b>3RF2330-1B.44</b>	3RF2900-0EA18	--		3RF2950-0GA16	3RF2932-0JA16	3RF2950-0KA16	3RF2950-0HA16
<b>3RF2330-1C.02</b>	3RF2900-0EA18	--		3RF2950-0GA13	--	--	3RF2950-0HA13
<b>3RF2330-1D.44</b>	3RF2900-0EA18	--		3RF2950-0GA16	3RF2932-0JA16	3RF2950-0KA16	3RF2950-0HA16
<b>3RF2330-3A.02</b>	3RF2900-0EA18	--		3RF2950-0GA13	--	3RF2950-0KA13	3RF2950-0HA13
<b>3RF2330-3A.04</b>	3RF2900-0EA18	--		3RF2950-0GA16	3RF2932-0JA16	3RF2950-0KA16	3RF2950-0HA16
<b>3RF2330-3A.06</b>	3RF2900-0EA18	--		3RF2950-0GA16	3RF2932-0JA16	3RF2950-0KA16	3RF2950-0HA16
<b>3RF2330-3A.22</b>	--	--		3RF2950-0GA33	--	--	3RF2950-0HA33
<b>3RF2330-3A.24</b>	--	--		3RF2950-0GA36	--	--	3RF2950-0HA36
<b>3RF2330-3A.26</b>	--	--		3RF2950-0GA36	--	--	3RF2950-0HA36
<b>3RF2330-3A.44</b>	3RF2900-0EA18	--		3RF2950-0GA16	3RF2932-0JA16	3RF2950-0KA16	3RF2950-0HA16
<b>Type current <math>I_e = 40</math> A</b>							
<b>3RF2340-1A.02</b>	3RF2900-0EA18	--		3RF2950-0GA13	--	3RF2950-0KA13	3RF2950-0HA13
<b>3RF2340-1A.04</b>	3RF2900-0EA18	--		3RF2950-0GA16	--	3RF2950-0KA16	3RF2950-0HA16
<b>3RF2340-1A.06</b>	3RF2900-0EA18	--		3RF2950-0GA16	--	3RF2950-0KA16	3RF2950-0HA16
<b>3RF2340-1A.14</b>	3RF2900-0EA18	--		3RF2950-0GA16	--	3RF2950-0KA16	3RF2950-0HA16
<b>3RF2340-1A.22</b>	--	--		3RF2950-0GA33	--	--	3RF2950-0HA33
<b>3RF2340-1A.24</b>	--	--		3RF2950-0GA36	--	--	3RF2950-0HA36
<b>3RF2340-1A.26</b>	--	--		3RF2950-0GA36	--	--	3RF2950-0HA36
<b>3RF2340-1A.45</b>	3RF2900-0EA18	--		3RF2950-0GA16	--	3RF2950-0KA16	3RF2950-0HA16
<b>3RF2340-1B.02</b>	3RF2900-0EA18	--		3RF2950-0GA13	--	3RF2950-0KA13	3RF2950-0HA13
<b>3RF2340-1B.04</b>	3RF2900-0EA18	--		3RF2950-0GA13	--	3RF2950-0KA16	3RF2950-0HA16
<b>3RF2340-1B.06</b>	3RF2900-0EA18	--		3RF2950-0GA13	--	3RF2950-0KA16	3RF2950-0HA16
<b>3RF2340-1B.22</b>	--	--		3RF2950-0GA33	--	--	3RF2950-0HA33
<b>3RF2340-1B.24</b>	--	--		3RF2950-0GA36	--	--	3RF2950-0HA36
<b>3RF2340-1B.26</b>	--	--		3RF2950-0GA36	--	--	3RF2950-0HA36
<b>3RF2340-3A.02</b>	3RF2900-0EA18	--		3RF2950-0GA13	--	3RF2950-0KA13	3RF2950-0HA13
<b>3RF2340-3A.04</b>	3RF2900-0EA18	--		3RF2950-0GA16	--	3RF2950-0KA16	3RF2950-0HA16
<b>3RF2340-3A.06</b>	3RF2900-0EA18	--		3RF2950-0GA16	--	3RF2950-0KA16	3RF2950-0HA16
<b>3RF2340-3A.22</b>	--	--		3RF2950-0GA33	--	--	3RF2950-0HA33
<b>3RF2340-3A.24</b>	--	--		3RF2950-0GA36	--	--	3RF2950-0HA36
<b>3RF2340-3A.26</b>	--	--		3RF2950-0GA36	--	--	3RF2950-0HA36
<b>3RF2340-3A.45</b>	3RF2900-0EA18	--		3RF2950-0GA16	--	3RF2950-0KA16	3RF2950-0HA16
<b>Type current <math>I_e = 50</math> A</b>							
<b>3RF2350-1A.02</b>	3RF2900-0EA18	--		3RF2950-0GA13	--	3RF2950-0KA13	3RF2950-0HA13
<b>3RF2350-1A.04</b>	3RF2900-0EA18	--		3RF2950-0GA16	--	3RF2950-0KA16	3RF2950-0HA16
<b>3RF2350-1A.06</b>	3RF2900-0EA18	--		3RF2950-0GA16	--	3RF2950-0KA16	3RF2950-0HA16
<b>3RF2350-1A.14</b>	3RF2900-0EA18	--		3RF2950-0GA16	--	3RF2950-0KA16	3RF2950-0HA16
<b>3RF2350-1A.22</b>	--	--		3RF2950-0GA33	--	--	3RF2950-0HA33
<b>3RF2350-1A.24</b>	--	--		3RF2950-0GA36	--	--	3RF2950-0HA36
<b>3RF2350-1A.26</b>	--	--		3RF2950-0GA36	--	--	3RF2950-0HA36
<b>3RF2350-1A.45</b>	3RF2900-0EA18	--		3RF2950-0GA16	--	3RF2950-0KA16	3RF2950-0HA16

<sup>1)</sup> The technical specifications must be taken into account when selecting the function modules. More combinations may be possible if the solid-state relays and contactors are not fully loaded, e.g. a load monitor for 20 A can also be operated with a solid-state contactor for 30 A if the load current during operation does not exceed 20 A.

<sup>2)</sup> For line voltages in the range from 110 to 230 V, the versions of the 3RF29...-0.A13 function modules can also be combined with more voltage-resistant versions of the solid-state contactors (3RF23...-...4, -...5 or -...6).

# Solid-State Switching Devices for Resistive Loads

## 3RF29 Function Modules

### General data

Type	Accessories					
	Converters	Load monitoring		Heating current monitoring <sup>1)</sup>	Power controllers <sup>1)</sup>	Power regulators <sup>1)</sup>
		Basic	Extended <sup>1)</sup>			
<b>Type current <math>I_e = 50</math> A</b>						
<b>3RF2350-1B.02</b>	3RF2900-0EA18	--	3RF2950-0GA13	--	3RF2950-0KA13	3RF2950-0HA13
<b>3RF2350-1B.04</b>	3RF2900-0EA18	--	3RF2950-0GA16	--	3RF2950-0KA16	3RF2950-0HA16
<b>3RF2350-1B.06</b>	3RF2900-0EA18	--	3RF2950-0GA16	--	3RF2950-0KA16	3RF2950-0HA16
<b>3RF2350-1B.22</b>	--	--	3RF2950-0GA33	--	--	3RF2950-0HA33
<b>3RF2350-1B.24</b>	--	--	3RF2950-0GA36	--	--	3RF2950-0HA36
<b>3RF2350-1B.26</b>	--	--	3RF2950-0GA36	--	--	3RF2950-0HA36
<b>3RF2350-1B.44</b>	3RF2900-0EA18	--	3RF2950-0GA16	--	3RF2950-0KA16	3RF2950-0HA16
<b>3RF2350-3A.02</b>	3RF2900-0EA18	--	3RF2950-0GA13	--	3RF2950-0KA13	3RF2950-0HA13
<b>3RF2350-3A.04</b>	3RF2900-0EA18	--	3RF2950-0GA16	--	3RF2950-0KA16	3RF2950-0HA16
<b>3RF2350-3A.06</b>	3RF2900-0EA18	--	3RF2950-0GA16	--	3RF2950-0KA16	3RF2950-0HA16
<b>3RF2350-3A.22</b>	--	--	3RF2950-0GA33	--	--	3RF2950-0HA33
<b>3RF2350-3A.24</b>	--	--	3RF2950-0GA36	--	--	3RF2950-0HA36
<b>3RF2350-3A.26</b>	--	--	3RF2950-0GA36	--	--	3RF2950-0HA36
<b>3RF2350-3A.44</b>	3RF2900-0EA18	--	3RF2950-0GA16	--	3RF2950-0KA16	3RF2950-0HA16
<b>Type current <math>I_e = 70</math> A</b>						
<b>3RF2370-1B.02</b>	3RF2900-0EA18	--	3RF2950-0GA13	--	3RF2950-0KA13	3RF2950-0HA13
<b>3RF2370-1B.04</b>	3RF2900-0EA18	--	3RF2950-0GA16	--	3RF2950-0KA16	3RF2950-0HA16
<b>3RF2370-1B.06</b>	3RF2900-0EA18	--	3RF2950-0GA16	--	3RF2950-0KA16	3RF2950-0HA16
<b>3RF2370-1B.22</b>	--	--	3RF2950-0GA33	--	--	3RF2950-0HA33
<b>3RF2370-1B.24</b>	--	--	3RF2950-0GA36	--	--	3RF2950-0HA36
<b>3RF2370-1B.26</b>	--	--	3RF2950-0GA36	--	--	3RF2950-0HA36
<b>3RF2370-3A.02</b>	3RF2900-0EA18	--	3RF2990-0GA13	--	3RF2990-0KA13	3RF2990-0HA13
<b>3RF2370-3A.04</b>	3RF2900-0EA18	--	3RF2990-0GA16	--	3RF2990-0KA16	3RF2990-0HA16
<b>3RF2370-3A.06</b>	3RF2900-0EA18	--	3RF2990-0GA16	--	3RF2990-0KA16	3RF2990-0HA16
<b>3RF2370-3A.22</b>	--	--	3RF2990-0GA33	--	--	3RF2990-0HA33
<b>3RF2370-3A.24</b>	--	--	3RF2990-0GA36	--	--	3RF2990-0HA36
<b>3RF2370-3A.26</b>	--	--	3RF2990-0GA36	--	--	3RF2990-0HA36
<b>3RF2370-3A.45</b>	3RF2900-0EA18	--	3RF2990-0GA16	--	3RF2990-0KA16	3RF2990-0HA16
<b>3RF2370-3B.02</b>	3RF2900-0EA18	--	3RF2990-0GA13	--	3RF2990-0KA13	3RF2990-0HA13
<b>3RF2370-3B.04</b>	3RF2900-0EA18	--	3RF2990-0GA16	--	3RF2990-0KA16	3RF2990-0HA16
<b>3RF2370-3B.06</b>	3RF2900-0EA18	--	3RF2990-0GA16	--	3RF2990-0KA16	3RF2990-0HA16
<b>3RF2370-3B.22</b>	--	--	3RF2990-0GA33	--	--	3RF2990-0HA33
<b>3RF2370-3B.24</b>	--	--	3RF2990-0GA36	--	--	3RF2990-0HA36
<b>3RF2370-3B.26</b>	--	--	3RF2990-0GA36	--	--	3RF2990-0HA36
<b>Type current <math>I_e = 90</math> A</b>						
<b>3RF2390-1B.02</b>	3RF2900-0EA18	--	3RF2950-0GA13	--	3RF2950-0KA13	3RF2950-0HA13
<b>3RF2390-1B.04</b>	3RF2900-0EA18	--	3RF2950-0GA16	--	3RF2950-0KA16	3RF2950-0HA16
<b>3RF2390-1B.06</b>	3RF2900-0EA18	--	3RF2950-0GA16	--	3RF2950-0KA16	3RF2950-0HA16
<b>3RF2390-1B.22</b>	--	--	3RF2950-0GA33	--	--	3RF2950-0HA33
<b>3RF2390-1B.24</b>	--	--	3RF2950-0GA36	--	--	3RF2950-0HA36
<b>3RF2390-1B.26</b>	--	--	3RF2950-0GA36	--	--	3RF2950-0HA36
<b>3RF2390-3A.02</b>	3RF2900-0EA18	--	3RF2990-0GA13	--	3RF2990-0KA13	3RF2990-0HA13
<b>3RF2390-3A.04</b>	3RF2900-0EA18	--	3RF2990-0GA16	--	3RF2990-0KA16	3RF2990-0HA16
<b>3RF2390-3A.06</b>	3RF2900-0EA18	--	3RF2990-0GA16	--	3RF2990-0KA16	3RF2990-0HA16
<b>3RF2390-3A.22</b>	--	--	3RF2990-0GA33	--	--	3RF2990-0HA33
<b>3RF2390-3A.24</b>	--	--	3RF2990-0GA36	--	--	3RF2990-0HA36
<b>3RF2390-3A.26</b>	--	--	3RF2990-0GA36	--	--	3RF2990-0HA36
<b>3RF2390-3A.45</b>	3RF2900-0EA18	--	3RF2990-0GA16	--	3RF2990-0KA16	3RF2990-0HA16
<b>3RF2390-3B.02</b>	3RF2900-0EA18	--	3RF2990-0GA13	--	3RF2990-0KA13	3RF2990-0HA13
<b>3RF2390-3B.04</b>	3RF2900-0EA18	--	3RF2990-0GA16	--	3RF2990-0KA16	3RF2990-0HA16
<b>3RF2390-3B.06</b>	3RF2900-0EA18	--	3RF2990-0GA16	--	3RF2990-0KA16	3RF2990-0HA16
<b>3RF2390-3B.22</b>	--	--	3RF2990-0GA33	--	--	3RF2990-0HA33
<b>3RF2390-3B.24</b>	--	--	3RF2990-0GA36	--	--	3RF2990-0HA36
<b>3RF2390-3B.26</b>	--	--	3RF2990-0GA36	--	--	3RF2990-0HA36

<sup>1)</sup> For line voltages in the range from 110 to 230 V, the versions of the 3RF29 ...0.A13 function modules can also be combined with more voltage-resistant versions of the solid-state contactors (3RF23 ...4, ...5 or ...6).

### Recommended assignment of the function modules to the 3RF24 three-phase solid-state contactors



Type	Accessories					
	Converters	Load monitoring		Heating current monitoring	Power controllers	Power regulators
		Basic	Extended			
<b>Type current up to 50 A</b>						
<b>3RF24...1.4.</b>	3RF2900-0EA18	--	--	--	--	--
<b>3RF24...2.4.</b>	--	--	--	--	--	--
<b>3RF24...3.4.</b>	3RF2900-0EA18	--	--	--	--	--
<b>3RF24...5.</b>	--	--	--	--	--	--

# Solid-State Switching Devices for Resistive Loads

## 3RF29 Function Modules

### General data

#### Technical specifications

Type		3RF29...-0EA..	3RF29...-0FA..	3RF29...-0GA..	3RF29...-0HA..	3RF29...-0JA..	3RF29...-0KA..
Dimensions (W x H x D)	mm	22.5 x 84 x 38	22.5 x 102 x 39	45 x 112 x 44	45 x 112 x 44	45 x 112 x 44	45 x 112 x 44
<b>General data</b>							
<b>Ambient temperature</b>							
• During operation, derating from 40 °C	°C	-25 ... +60					
• During storage	°C	-55 ... +80					
<b>Installation altitude</b>	m	0 ... 1000; derating from 1000					
<b>Shock resistance</b> acc. to IEC 60068-2-27	g/ms	15/11					
<b>Vibration resistance</b> acc. to IEC 60068-2-6	g	2					
<b>Degree of protection</b>		IP20					
<b>Electromagnetic compatibility (EMC)</b>							
• Emitted interference							
- Conducted interference voltage according to IEC 60947-4-3		Class A for industrial applications <sup>1)</sup>					
- Emitted, high-frequency interference voltage according to IEC 60947-4-3		Class B for residential, business and commercial applications					
• Interference immunity							
- Electrostatic discharge according to IEC 61000-4-2 (corresponds to degree of severity 3)	kV	Contact discharge 4; air discharge 8; behavior criterion 2					
- Induced RF fields according to IEC 61000-4-6	MHz	0.15 ... 80; 140 dB $\mu$ V; behavior criterion 1					
- Burst acc. to IEC 61000-4-4		2 kV/5.0 kHz; behavior criterion 2					
- Surge acc. to IEC 61000-4-5	kV	Conductor - ground 2; conductor - conductor 1; behavior criterion 2					
<b>Connection type</b>							
Auxiliary/control contacts		 <b>Screw terminals</b>					
• Conductor cross-section	mm <sup>2</sup>	1 x (0.5 ... 2.5), 2 x (0.5 ... 1.0), 1 x (AWG 20 ... 12)					
• Stripped length	mm	7					
• Terminal screw		M3					
• Tightening torque	Nm lb.in	0.5 ... 0.6 4.5 ... 5.3					
<b>Connection type</b>							
Converters		 <b>Straight-through transformers</b>					
• Diameter	mm	--	7	17			

<sup>1)</sup> Note limitations for power controller function modules. These modules were built as Class A devices. The use of these devices in residential areas could result in lead in radio interference. In this case these may be required to introduce additional interference suppression measures.

Type		3RF29...-0EA18	3RF29...-0FA08	3RF29...-0GA.3	3RF29...-0GA.6
<b>Main circuit</b>					
<b>Rated operational voltage <math>U_e</math></b>	V AC	-- <sup>1)</sup>			110 ... 230
• Operating range	V AC	--			93.5 ... 253
• Rated frequency	Hz	--			50/60
<b>Rated insulation voltage <math>U_i</math></b>	V	--			600
<b>Voltage measuring</b>					
• Measuring range	V	--			93.5 ... 253
<b>Mains voltage, fluctuation compensation</b>	%	--			20

<sup>1)</sup> Versions are independent of the main circuit.

Type		3RF29...-0HA.3 3RF29...-0KA.3	3RF29...-0HA.6 3RF29...-0KA.6	3RF29...-0JA.3	3RF29...-0JA.6
<b>Main circuit</b>					
<b>Rated operational voltage <math>U_e</math></b>	V AC	110 ... 230	400 ... 600	110 ... 230	400 ... 600
• Operating range	V AC	93.5 ... 253	340 ... 660	93.5 ... 253	340 ... 660
• Rated frequency	Hz	50/60			
<b>Rated insulation voltage <math>U_i</math></b>	V	600			
<b>Voltage measuring</b>					
• Measuring range	V	93.5 ... 253	340 ... 660	93.5 ... 253	340 ... 660
<b>Mains voltage, fluctuation compensation</b>	%	20			

# Solid-State Switching Devices for Resistive Loads

## 3RF29 Function Modules

### General data

Type		3RF29...-...0.	3RF29...-...1.	3RF29...-...3.
<b>Control circuit</b>				
<b>Method of operation</b>		DC operation	AC/DC operation	AC operation
<b>Rated control supply voltage <math>U_s</math></b>	V	24	24	110
<b>Rated control current</b>	mA	15	15	15
<b>Rated frequency</b> of the control supply voltage	Hz	--	50/60	50/60
<b>Actuating voltage, max.</b>	V	30	30	121
<b>Rated control current</b> At maximum voltage	mA	15	15	15
<b>Response voltage</b>	V	15	15	90
• For operating current	mA	2	2	2
<b>Drop-out voltage</b>	V	5	5	15

Type		3RF2906-0FA08	3RF2920-0FA08	3RF2920-0GA..	3RF2950-0GA..	3RF2990-0GA..
<b>Current measurement</b>						
<b>Rated operational current <math>I_e</math></b>	A	6	20	20	50	90
<b>Current measurement</b>						
• Teach range	A	0.25 ... 6	0.65 ... 20	0.56 ... 20	1.62 ... 50	2.93 ... 90
• Measuring range	A	0 ... 6.6	0 ... 22	0 ... 22	0 ... 55	0 ... 99
• Minimum partial load current	A	0.25	0.65	0.65	1.6	2.9
<b>Number of partial loads</b>		1 ... 6	1 ... 6	1 ... 12		

Type		3RF2920-0HA..	3RF2950-0HA..	3RF2990-0HA..	3RF2916-0JA..	3RF2932-0JA..
<b>Current measurement</b>						
<b>Rated operational current <math>I_e</math></b>	A	20	50	90	16	32
<b>Current measurement</b>						
• Teach range	A	4 ... 20	10 ... 50	18 ... 90	0.42 ... 16	0.8 ... 32
• Measuring range	A	0 ... 22	0 ... 55	4 ... 99	0 ... 16	0 ... 32
• Minimum partial load current	A	--	--	--	0.42	0.8
<b>Number of partial loads</b>		--	--	--	1 ... 6	--

Type		3RF2904-0KA..	3RF2920-0KA..	3RF2950-0KA..	3RF2990-0KA..
<b>Current measurement</b>					
<b>Rated operational current <math>I_e</math></b>	A	4	20	50	90
<b>Current measurement</b>					
• Teach range	A	0.15 ... 4	0.65 ... 20	1.6 ... 50	2.9 ... 90
• Measuring range	A	0 ... 4	0 ... 22	0 ... 55	0 ... 99
• Minimum partial load current	A	--	0.65	1.6	2.9
<b>Number of partial loads</b>		--	1 ... 6	--	--

### Circuit diagrams

#### Converters

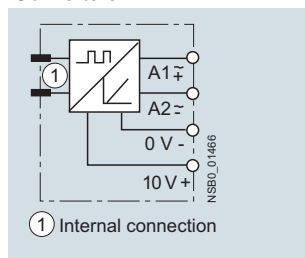

#### Extended load monitoring

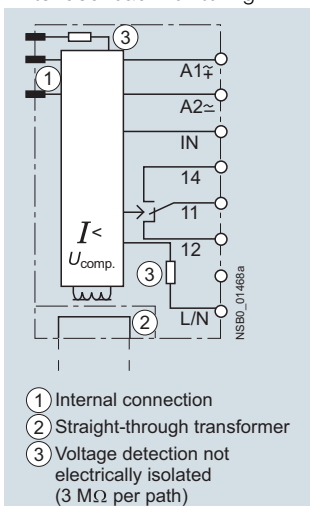

#### Heating current monitoring

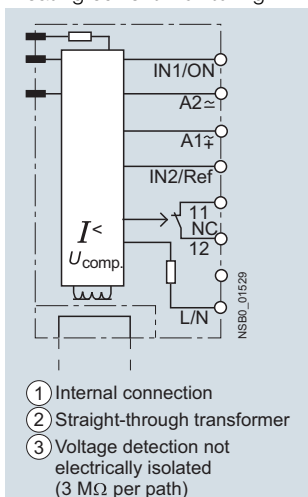

#### Power controller and regulator

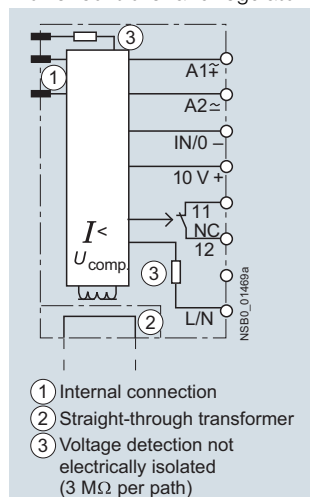

#### Basic load monitoring

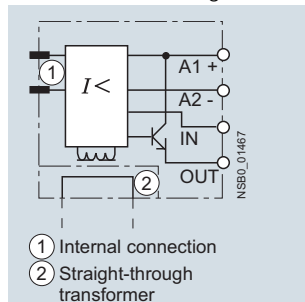



# Solid-State Switching Devices for Resistive Loads

## 3RF29 Function Modules

SIRIUS converters for 3RF2

### Overview

#### Converters for 3RF2 solid-state switching devices

These modules are used to convert analog control signals, such as those output from many temperature controllers for example, into a pulse-width-modulated digital signal. The connected solid-state contactors and relays can therefore regulate the output of a load as a percentage.



### Application

This function module is used for conversions from an analog input signal to an on/off ratio with time basis 1 s. The module can only be used in conjunction with 3RF21 and 3RF23 single-phase solid-state switching devices or 3RF22 and 3RF24 three-phase devices. It can be used on versions with 24 V DC and 24 V AC/DC control supply voltage.

#### Note:

The use of single-pole solid-state switching devices with converters, power controllers or power regulators on AC loads in full-wave control mode is not recommended. As mutual synchronization of the function modules is not possible, fluctuations in the heating power are possible; there is no optimum settling in particular with setpoint values < 50 %.

### Selection and ordering data

Rated operational current $I_e$	Rated operational voltage $U_e$	DT	Screw terminals 	PU (UNIT, SET, M)	PS*	PG
A	V		Configurator 			
			Article No.	Price per PU		

#### Converters



3RF2900-0EA18

 Online configurator see [www.siemens.com/sirius/configurators](http://www.siemens.com/sirius/configurators)

Rated control supply voltage 24 V AC/DC						
--	--	A	<b>3RF2900-0EA18</b>	1	1 unit	41C

# Solid-State Switching Devices for Resistive Loads

## 3RF29 Function Modules

### SIRIUS load monitoring for 3RF2

#### Overview

##### Load monitoring for 3RF2 single-phase solid-state switching devices

Many faults can be quickly detected by monitoring a load circuit connected to the solid-state switching device, as made possible with this module. Examples include the failure of load elements (up to 6 in the basic version or up to 12 in the extended version), alloyed power semiconductors, a lack of voltage or a break in a load circuit. A fault is indicated by one or more LEDs and reported to the controller by way of a PLC-compatible output.

The principle of operation is based on permanent monitoring of the current intensity. This figure is continuously compared with the reference value stored once during start-up by the simple press of a button. In order to detect the failure of one of several loads, the current difference must be 1/6 (in the basic version) or 1/12 (in the extended version) of the reference value. In the event of a fault, an output is actuated and one or more LEDs indicate the fault.

#### Application

The device is used for monitoring one or more loads (partial loads). The function module can only be used in conjunction with a 3RF21 solid-state relay or a 3RF23 solid-state contactor. The devices with spring-type connections in the load circuit are not suitable.

#### Selection and ordering data

Rated operational current $I_e$	Rated operational voltage $U_e$	DT	Screw terminals	PU (UNIT, SET, M)	PS*	PG
			Configurator			
			Article No.	Price per PU		
<b>Basic load monitoring</b>						
Rated control supply voltage 24 V DC						
6	--	A	<b>3RF2906-0FA08</b>	1	1 unit	41C
20	--	A	<b>3RF2920-0FA08</b>	1	1 unit	41C
• With mounted 3RF2900-ORA88 cover						
6	--	A	<b>3RF2906-0FA08-0KH0</b>	1	1 unit	41C
20	--	A	<b>3RF2920-0FA08-0KH0</b>	1	1 unit	41C
<b>Extended load monitoring</b>						
Rated control supply voltage 24 V AC/DC						
20	110 ... 230	A	<b>3RF2920-0GA13</b>	1	1 unit	41C
20	400 ... 600	A	<b>3RF2920-0GA16</b>	1	1 unit	41C
50	110 ... 230	A	<b>3RF2950-0GA13</b>	1	1 unit	41C
50	400 ... 600	A	<b>3RF2950-0GA16</b>	1	1 unit	41C
90	110 ... 230	A	<b>3RF2990-0GA13</b>	1	1 unit	41C
90	400 ... 600	A	<b>3RF2990-0GA16</b>	1	1 unit	41C
Rated control supply voltage 110 V AC						
20	110 ... 230	A	<b>3RF2920-0GA33</b>	1	1 unit	41C
20	400 ... 600	A	<b>3RF2920-0GA36</b>	1	1 unit	41C
50	110 ... 230	A	<b>3RF2950-0GA33</b>	1	1 unit	41C
50	400 ... 600	A	<b>3RF2950-0GA36</b>	1	1 unit	41C
90	110 ... 230	A	<b>3RF2990-0GA33</b>	1	1 unit	41C
90	400 ... 600	A	<b>3RF2990-0GA36</b>	1	1 unit	41C

Online configurator see [www.siemens.com/sirius/configurators](http://www.siemens.com/sirius/configurators)

Version	DT	Article No.	Price per PU	PU (UNIT, SET, M)	PS*	PG
---------	----	-------------	-----------------	-------------------------	-----	----

#### Optional accessories



3RF2900-ORA88

**Sealable covers  
for function modules** (not for converters)

B **3RF2900-ORA88** 1 10 units 41C

# Solid-State Switching Devices for Resistive Loads

## 3RF29 Function Modules

### SIRIUS heating current monitoring for 3RF2

#### Overview

##### Heating current monitoring for 3RF2 single-phase solid-state switching devices

Many faults can be quickly detected by monitoring a load circuit connected to the solid-state switching device, as made possible with this module. Examples include the failure of up to six load elements, alloyed power semiconductors, a lack of voltage, or a break in the load circuit. A fault is indicated by LEDs and reported to the controller via relay output (NC).

The principle of operation is based on permanent monitoring of the current intensity. This figure is continuously compared with the reference value stored once during start-up. In order to detect the failure of one of several loads, the current difference must be 1/6 of the reference value. In the event of a fault, an output is actuated and the LEDs indicate the fault.

The heating current monitoring has a teach input and therefore differs from the load monitoring. This remote teaching function enables simple adjustment to changing loads without manual intervention.

#### Special versions:

##### deviations from the standard version

3RF29...0JA1.-1KK0

If the current is below 50 % of the lower teach current during the teach routine, the device will go into "Standby" mode; the LOAD LED will flicker. The device thus detects a non-connected load, e.g. channels not required for tool heaters, and does not signal a fault. This mode can be reset by re-teaching.

#### Application

The device is used for monitoring one or more loads (partial loads). The function module can only be used in conjunction with a 3RF21 solid-state relay or a 3RF23 solid-state contactor. The devices with spring-type connections in the load circuit are not suitable.

#### Selection and ordering data

Rated operational current $I_e$	Rated operational voltage $U_e$	DT	Screw terminals	PU (UNIT, SET, M)	PS*	PG
A	V		Configurator			
			Article No.	Price per PU		

#### Heating current monitoring<sup>1)</sup>



3RF29

Rated control supply voltage 24 V AC/DC

16	110 ... 230	A	<b>3RF2916-0JA13</b>	1	1 unit	41C
16	110 ... 230	A	<b>3RF2916-0JA13-1KK0</b>	1	1 unit	41C
16	400 ... 600	A	<b>3RF2916-0JA16-1KK0</b>	1	1 unit	41C
32	110 ... 230	A	<b>3RF2932-0JA13-1KK0</b>	1	1 unit	41C
32	400 ... 600	A	<b>3RF2932-0JA16</b>	1	1 unit	41C
32	400 ... 600	A	<b>3RF2932-0JA16-1KK0</b>	1	1 unit	41C

Online configurator see [www.siemens.com/sirius/configurators](http://www.siemens.com/sirius/configurators)

<sup>1)</sup> Supplied without control connector. The control connector can be purchased from Phoenix Contact by quoting Article No. 1982 790 (2.5 HC/6-ST-5.08).

Version	DT	Article No.	Price per PU	PU (UNIT, SET, M)	PS*	PG
---------	----	-------------	--------------	-------------------	-----	----

#### Optional accessories



3RF2900-ORA88

<b>Sealable covers for function modules</b> (not for converters)	B	<b>3RF2900-ORA88</b>		1	10 units	41C
--	---	----------------------	--	---	----------	-----

# Solid-State Switching Devices for Resistive Loads

## 3RF29 Function Modules

### SIRIUS power controllers for 3RF2

#### Overview

##### Power controllers for 3RF2 single-phase solid-state switching devices

The power controller is a function module for the autonomous power control of complex heating systems and inductive loads.

The following functions have been integrated:

- **Power controller** for adjusting the power of the connected load. The setpoint value is selected via a rotary knob on the module as a percentage of the 100% power value stored.
- **Inrush current limitation:** With the aid of an adjustable voltage ramp, the inrush current is limited by means of phase control. This is useful above all with loads such as lamps or infrared lamps which have an inrush transient current.
- **Load circuit monitoring** for detecting load failure, partial load faults, allowed power semiconductors, lack of voltage or a break in the load circuit.

##### Note:

With the phase control operating mode, a partial load fault is detected by cyclic "scanning" of the load; the exact mode of operation is described in the data sheets!

##### Special versions: deviations from the standard version

###### 3RF29 04-0KA13-0KC0

During the teach routine, the connected solid-state relay or contactor is not activated; i.e. no current will flow. No current reference value is stored. No part-load monitoring!

###### 3RF29 ..-0KA1.-0KT0

No part-load monitoring!

#### Application

The power controller can be used for:

- Complex heating systems
- Inductive loads
- Loads with temperature-dependent resistor
- Loads with ageing after long-time service
- Simple indirect control of temperature

##### Power control

The power controller adjusts the power in the connected load by means of a solid-state switching device depending on the setpoint selection. It does not compensate for changes in the mains voltage or load resistance. The setpoint value can be predefined externally as a 0 to 10 V signal or internally by means of a potentiometer. Depending on the setting of the potentiometer ( $t_R$ ), the control is carried out according to the principle of full-wave control or generalized phase control.

##### Note:

In the case of ohmic loads, the power is set linear to the setpoint value. During operation of inductive loads, the power control is no longer proportional and linear due to the phase shift between current and voltage.

##### Full-wave control

In this operating mode the output is adjusted to the required setpoint value by changing the on-to-off period. The period duration is predefined at one second.

See note about AC loads on page 6/105.

##### Generalized phase control

In this operating mode the output is adjusted to the required setpoint value by changing the current flow angle. In order to observe the limit values of the conducted interference voltage for industrial networks, the load circuit must include a reactor with a rating of at least 200  $\mu$ H.

#### Selection and ordering data

Rated operational current $I_e$	Rated operational voltage $U_e$	DT	Screw terminals		PU (UNIT, SET, M)	PS*	PG
			Configurator	Price per PU			
A	V		Article No.	Price per PU			
<b>Power controllers</b>							
Rated control supply voltage 24 V AC/DC							
4	110 ... 230	A	<b>3RF2904-0KA13-0KC0</b>	1	1 unit	41C	
4		A	<b>3RF2904-0KA13-0KT0</b>	1	1 unit	41C	
20		A	<b>3RF2920-0KA13</b>	1	1 unit	41C	
50		A	<b>3RF2950-0KA13</b>	1	1 unit	41C	
90		A	<b>3RF2990-0KA13</b>	1	1 unit	41C	
20	400 ... 600	A	<b>3RF2920-0KA16</b>	1	1 unit	41C	
50		A	<b>3RF2950-0KA16</b>	1	1 unit	41C	
50		A	<b>3RF2950-0KA16-0KT0</b>	1	1 unit	41C	
90		A	<b>3RF2990-0KA16</b>	1	1 unit	41C	

Online configurator see [www.siemens.com/sirius/configurators](http://www.siemens.com/sirius/configurators)

Version	DT	Article No.	Price per PU	PU (UNIT, SET, M)	PS*	PG
<b>Optional accessories</b>						
	B	<b>3RF2900-ORA88</b>		1	10 units	41C
Sealable covers for function modules (not for converters)						
3RF2900-ORA88						

# Solid-State Switching Devices for Resistive Loads

## 3RF29 Function Modules

### SIRIUS power regulators for 3RF2

#### Overview

##### Power regulators for 3RF2 single-phase solid-state switching devices

The power regulator is a function module for the autonomous power control of complex heating systems.

The following functions have been integrated:

- **Power controller with proportional-action control** for adjusting the power of the connected load. The setpoint value is selected via a rotary knob on the module as a percentage of the 100% power value stored. Changes in the mains voltage or in the load resistance are compensated in this case.
- **Inrush current limitation**: With the aid of an adjustable voltage ramp, the inrush current is limited by means of phase control. This is useful above all with loads such as lamps which have an inrush transient current.
- **Load circuit monitoring** for detecting load failure, alloyed power semiconductors, lack of voltage or a break in the load circuit. Part-load monitoring is not possible. Load fluctuations are compensated.

#### Application

The power regulator can be used for:

- Complex heating systems
- Heating elements with temperature-dependent resistor
- Heating elements with ageing after long-time service
- Simple indirect control of temperature

#### Selection and ordering data

Rated operational current $I_e$	Rated operational voltage $U_e$	DT	Screw terminals	Configurator	PU (UNIT, SET, M)	PS*	PG
A	V						
<b>Power regulators</b>							
Rated control supply voltage 24 V AC/DC							
20	110 ... 230	A	<b>3RF2920-0HA13</b>		1	1 unit	41C
20	400 ... 600	A	<b>3RF2920-0HA16</b>		1	1 unit	41C
50	110 ... 230	A	<b>3RF2950-0HA13</b>		1	1 unit	41C
50	400 ... 600	A	<b>3RF2950-0HA16</b>		1	1 unit	41C
90	110 ... 230	A	<b>3RF2990-0HA13</b>		1	1 unit	41C
90	400 ... 600	A	<b>3RF2990-0HA16</b>		1	1 unit	41C
Rated control supply voltage 110 V AC							
20	110 ... 230	A	<b>3RF2920-0HA33</b>		1	1 unit	41C
20	400 ... 600	A	<b>3RF2920-0HA36</b>		1	1 unit	41C
50	110 ... 230	A	<b>3RF2950-0HA33</b>		1	1 unit	41C
50	400 ... 600	A	<b>3RF2950-0HA36</b>		1	1 unit	41C
90	110 ... 230	A	<b>3RF2990-0HA33</b>		1	1 unit	41C
90	400 ... 600	A	<b>3RF2990-0HA36</b>		1	1 unit	41C



3RF29

Online configurator see [www.siemens.com/sirius/configurators](http://www.siemens.com/sirius/configurators)

Version	DT	Article No.	Price per PU	PU (UNIT, SET, M)	PS*	PG
	B	<b>3RF2900-ORA88</b>		1	10 units	41C

#### Optional accessories



3RF2900-ORA88

**Sealable covers for function modules** (not for converters)

#### Power control

The power regulator adjusts the power in the connected load by means of a solid-state switching device depending on the taught power and the selected setpoint. Changes in the mains voltage or in the load resistance are thus compensated by the power regulator. The setpoint value can be predefined externally as a 0 to 10 V signal or internally by means of a potentiometer. Depending on the setting of the potentiometer ( $t_R$ ), the adjustment is carried out according to the principle of full-wave control or generalized phase control.

#### Note:

In the case of ohmic loads, the power is set linear to the setpoint value. During operation of inductive loads, the power control is no longer proportional and linear due to the phase shift between current and voltage.

#### Full-wave control

In this operating mode the output is adjusted to the required setpoint value by changing the on-to-off period. The period duration is predefined at one second.

See note about AC loads on page 6/105.

#### Generalized phase control

In this operating mode the output is adjusted to the required setpoint value by changing the current flow angle. In order to observe the limit values of the conducted interference voltage for industrial networks, the load circuit must include a reactor with a rating of at least 200  $\mu$ H.

# Solid-State Switching Devices for Switching Motors

## Solid-State Contactors

### General data

#### Overview

#### Solid-state contactors for switching motors



Solid-state contactor for direct-on-line starting

The solid-state contactors for switching motors are intended for frequently switching on and off three-phase current operating mechanisms up to 7.5 kW and reversing up to 3.0 kW. The devices are constructed with complete insulation and can be mounted directly on SIRIUS motor starter protectors, overload relays and current monitoring relays, resulting in a very simple integration into motor feeders.

These three-phase solid-state contactors are equipped with a two-phase control which is particularly suitable for typical motor current circuits without connecting to the neutral conductor.

Important features:

- Insulated enclosure with integrated heat sink
- Degree of protection IP20
- Integrated mounting foot to snap on a standard mounting rail or for assembly onto a support plate
- Variety of connection methods
- Plug-in control connection
- Display via LEDs
- Wide voltage range for AC control supply voltage

#### Switching functions

The solid-state contactors for switching motors are "instantaneous switching" because this method is particularly suited for inductive loads. By distributing the ON point over the entire sine curve of the mains voltage, disturbances are reduced to a minimum.

#### Connection methods

You can choose between the following connection methods for the solid-state contactors for switching motors:

##### Screw connection

The screw connection system is the standard among industrial controls. Open terminals and a plus-minus screw are just two features of this technology. Two conductors of up to 6 mm<sup>2</sup> can be connected in just one terminal.

##### Spring-type terminals

This innovative technology manages without any screw connection. This means that very high vibration resistance is achieved. Two conductors of up to 2.5 mm<sup>2</sup> can be connected to each terminal.

#### Motor feeders

The devices can use a link module to directly connect to a circuit breaker. Also possible is the mounting of a 3RB30/3RB31 solid-state overload relay (see Chapter 7 "Protection Equipment") or a 3RR2 current monitoring relay (see Chapter 10 "Monitoring and Control Devices") using a link adapter. The simultaneous mounting of a motor starter protector and an overload or current monitoring relay is not recommended for space and heat development reasons.

Rapid-switching fuseless and fuse motor feeders can thereby be implemented in a time-saving manner.

#### Selecting solid-state contactors

The solid-state contactors are selected on the basis of details of the network, the load and the ambient conditions.

The following procedure is recommended:

- Determine the rated current of the load and the mains voltage
- Select a solid-state contactor with the same or higher rated current than the load
- Testing of the maximum permissible switching frequency based on the characteristic curves (see "More Information" → "Product Information"). To do this, the starting current, the starting time and the motor loaded in in the operating phase must be known.
- If the permissible switching frequency is under the desired frequency, it is possible to achieve an increase only by overdimensioning the motor and the solid-state contactor!

Alternatively, the tool for "Selection of solid-state contactors for switching motors" can be used. The correct device size can be determined by entering the network and motor data along with the application and ambient conditions.

See [www.siemens.com/solid-state-switching-devices](http://www.siemens.com/solid-state-switching-devices).

#### Short-circuit protection

Despite the rugged power semiconductors that are used, solid-state switching devices respond more sensitively to short circuits in the load feeder. Consequently, special precautions have to be taken against destruction, depending on the type of design.

Siemens generally recommends using SITOR semiconductor fuses. These fuses also provide protection against destruction in the event of a short circuit even when the solid-state contactors and solid-state relays are fully utilized.

Alternatively, if there is lower loading, protection can also be provided by standard fuses or miniature circuit breakers. This protection is achieved by overdimensioning the solid-state switching devices accordingly.

#### More information

For additional information, see system manual "SIRIUS Innovations - System Overview" and manual "SIRIUS Innovations - 3RF34 Solid-State Switching Devices":

<http://support.automation.siemens.com/WW/view/en/60311318>  
<http://support.automation.siemens.com/WW/view/en/60298187>

#### Product information and technical specifications

For product data sheets with detailed technical specifications, dimensional drawings and characteristic curves, see [www.siemens.com/sirius/support/](http://www.siemens.com/sirius/support/)

For additional information, please enter the article number of the required device under the tab "Product List".

# Solid-State Switching Devices for Switching Motors

## Solid-State Contactors

### General data

#### Article No. scheme

Digit of the Article No.	1st - 3rd	4th	5th	6th	7th		8th	9th	10th	11th	12th
	□□□	□	□	□	□	-	□	□	□	□	□
<b>Solid-state switching devices</b>	<b>3 R F</b>										
<b>SIRIUS solid-state switching device generation</b>		□									
<b>Design</b>			□								
<b>Rated operational current</b>				□	□						
<b>Connection type</b>							□				
<b>Switching function</b>								□			
<b>Number of controlled phases</b>									□		
<b>Rated control supply voltage</b>										□	
<b>Rated operational voltage</b>											□
<b>Example</b>	<b>3 R F</b>	<b>3</b>	<b>4</b>	<b>1</b>	<b>0</b>	<b>-</b>	<b>1</b>	<b>B</b>	<b>B</b>	<b>0</b>	<b>4</b>

#### Note:

The Article No. scheme is presented here merely for information purposes and for better understanding of the logic behind the article numbers.

For your orders, please use the article numbers quoted in the catalog in the Selection and ordering data.

#### Benefits

- Units with integrated heat sink, "ready to use"
- Compact and space-saving design
- Reversing contactors with integrated interlocking

#### Application

##### Use in load feeders

There is no typical design of a load feeder with solid-state relays or solid-state contactors; instead, the great variety of connection methods and control voltages offers universal application opportunities. SIRIUS solid-state relays and solid-state contactors can be installed in fuseless or fused feeders, as required.

See the Configuration Manual "Configuring SIRIUS Innovations – Selection Data for Fuseless and Fused Load Feeders", <http://support.automation.siemens.com/WW/view/en/39714188>

##### Standards and approvals

- IEC 60947-4-2
- UL 508, CSA for North America<sup>1)</sup>
- CE marking for Europe
- C-Tick approval for Australia
- CCC approval for China



<sup>1)</sup> Please note: Use overvoltage protection device; max. cut-off-voltage 6000 V; min. energy handling capability 100 J.

# Solid-State Switching Devices for Switching Motors

## Solid-State Contactors

### General data

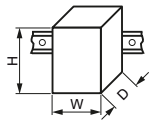
#### Technical specifications

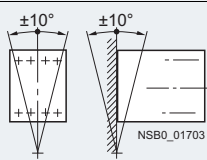
Type		3RF3405-1BB.. 3RF3403-1BD.. 3RF3405-1BD..	3RF3410-1BB.. 3RF3412-1BB.. 3RF3416-1BB.. 3RF3410-1BD..	3RF3405-2BB..	3RF3410-2BB.. 3RF3412-2BB.. 3RF3416-2BB..
Dimensions (W x H x D)		mm mm	mm mm	mm	mm
• 3RF34..-1BB.. • 3RF34..-1BD..		45 x 95 x 96.5 45 x 95 x 108.5	90 x 95 x 96.5 90 x 95 x 108.5	45 x 95 x 96.5 --	90 x 95 x 96.5 --
<b>General technical specifications</b>					
<b>Ambient temperature</b>					
• During operation, derating from 40 °C	°C	-25 ... +60			
• During storage	°C	-55 ... +80			
<b>Installation altitude</b>					
	m	0 ... 1 000; derating over 1 000 m on request			
<b>Shock resistance</b> acc. to IEC 60068-2-27					
	g/ms	15/11			
<b>Vibration resistance</b> acc. to IEC 60068-2-6					
	g	2			
<b>Degree of protection</b>					
		IP20			
<b>Insulation strength</b> at 50/60 Hz (main/control circuit to floor)					
	V rms	4000			
<b>Electromagnetic compatibility (EMC)</b>					
• Emitted interference according to IEC 60947-4-2					
- Conducted interference voltage		Class A for industrial applications <sup>1)</sup>			
- Emitted, high-frequency interference voltage		Class A for industrial applications			
• Interference immunity					
- Electrostatic discharge according to IEC 61000-4-2 (corresponds to degree of severity 3)	kV	Contact discharge: 4; Air discharge: 8; Behavior criterion 2			
- Induced RF fields according to IEC 61000-4-6	MHz	0.15 ... 80; 140 dBµV; behavior criterion 1			
- Burst acc. to IEC 61000-4-4	kV	2; at 5 kHz; behavior criterion 2			
- Surge according to IEC 61000-4-5 <sup>2)</sup>	kV	Conductor - Ground: 2; Conductor - Conductor: 1; Behavior criterion 2			
<b>Connection type</b>		 <b>Screw terminals</b>		 <b>Spring-type terminals</b>	
<b>Operating devices</b>		Standard screwdriver size 2 and Pozidriv 2		3.0 x 0.5 and 3.5 x 0.5	
<b>Conductor cross-sections, main contacts</b>					
• Solid	mm <sup>2</sup>	2 x (1.5 ... 2.5) <sup>3)</sup> , 2 x (2.5 ... 6) <sup>3)</sup>		2 x (0.5 ... 2.5)	
• Finely stranded with end sleeve	mm <sup>2</sup>	2 x (1 ... 2.5) <sup>3)</sup> , 2 x (2.5 ... 6) <sup>3)</sup> , 1 x 10		2 x (0.5 ... 1.5)	
• Finely stranded without end sleeve	mm <sup>2</sup>	--		2 x (0.5 ... 2.5)	
• AWG cables, solid or stranded		2 x (AWG 14 ... 10)		2 x (AWG 18 ... 14)	
<b>Conductor cross-sections, auxiliary/control contacts</b>					
• With/without end sleeve	mm <sup>2</sup>	1 x (0.5 ... 2.5), 2 x (0.5 ... 1.0)		0.5 ... 2.5	
• AWG cables, solid or stranded		AWG 20 ... 12		AWG 20 ... 12	
<b>Permissible mounting position</b>					
					

<sup>1)</sup> These products were built as Class A devices. The use of these devices in residential areas could result in lead in radio interference. In this case these may be required to introduce additional interference suppression measures.

<sup>2)</sup> The following applies for reversing contactors: To maintain the values, a 3TX7462-3L surge suppressor (see "3TB Contactors", Chapter 3) should be used between phases L1 and L3 as close as possible to the reversing contactor.

<sup>3)</sup> If two different conductor cross-sections are connected to one clamping point, both cross-sections must lie in one of the ranges specified.



# Solid-State Switching Devices for Switching Motors

## Solid-State Contactors

### SIRIUS 3RF34 solid-state contactors, three-phase

#### Overview

These two-phase controlled, instantaneous switching solid-state contactors in the insulating enclosure are offered in width 45 mm up to 5.2 A – and in width 90 mm up to 16 A. They allow the operation of motors up to 7.5 kW.

#### Technical specifications

Type		3RF3405-.BB..	3RF3410-.BB..	3RF3412-.BB..	3RF3416-.BB..
<b>Fuseless design with 3RV2 motor starter protector, CLASS 10</b>					
<b>Rated operational current <math>I_{AC-53}</math><sup>1)</sup></b> according to IEC 60947-4-2					
• At 40 °C	A	5.2 (4.5)	9.2	12.5	16
• UL/CSA, at 50 °C	A	4.6 (4.0)	8.4	11.5	14
• At 60 °C	A	4.2 (3.5)	7.6	10.5	12.5
<b>Power loss at <math>I_{AC-53}</math></b>					
• At 40 °C	W	10 (8)	16	22	28
<b>Short-circuit protection with type of coordination '1'</b> at an operational voltage of $U_b$ to 440 V					
• Motor starter protector, type		3RV2011-1GA10	3RV2011-1JA10	3RV2011-1KA10	3RV2011-4AA10
• Current $I_q$	kA	50	5	5	3

<sup>1)</sup> The reduced values in brackets apply to a directly mounted circuit breaker and simultaneous side-by-side mounting.

Type		3RF3405-.BB.4	3RF3405-.BB.6	3RF3410-.BB..	3RF3412-.BB.4	3RF3412-.BB.6	3RF3416-.BB..
<b>Fused design with directly connected 3RB3 overload relay</b>							
<b>Rated operational current <math>I_{AC-53}</math></b> according to IEC 60947-4-2							
• At 40 °C	A	4		7.8	9.5		11
• UL/CSA, at 50 °C	A	3.6		7	8.5		10
• At 60 °C	A	3.2		6.2	7.6		9
<b>Power loss at <math>I_{AC-53}</math></b>							
• At 40 °C	W	7		13	16		18
<b>Minimum load current</b>	A	0.1	0.5				
<b>Max. off-state current</b>	mA	10					
<b>Rated peak withstand current <math>I_{tsm}</math></b>	A	200	600	600	1 200	1 150	1 150
<b><math>I^2t</math> value</b>	A <sup>2</sup> s	200	1 800	1 800	7 200	6 600	6 600

Type		3RF34...BB.4	3RF34...BB.6
<b>Main circuit</b>			
<b>Controlled phases</b>		2-phase	2-phase
<b>Rated operational voltage <math>U_e</math></b>	V AC	48 ... 480	48 ... 600
• Operating range	V AC	40 ... 506	40 ... 660
• Rated frequency	Hz	50/60 ± 10 %	50/60 ± 10 %
<b>Rated insulation voltage <math>U_i</math></b>	V	600	600
<b>Rated impulse withstand voltage <math>U_{imp}</math></b>	kV	6	6
<b>Blocking voltage</b>	V	1 200	1 600
<b>Rate of voltage rise</b>	V/μs	1 000	1 000

# Solid-State Switching Devices for Switching Motors

## Solid-State Contactors

### SIRIUS 3RF34 solid-state contactors, three-phase

Type	3RF34...BB0.		3RF34...BB2.
<b>Control circuit</b>			
<b>Method of operation</b>	DC operation		AC operation
<b>Rated control supply voltage <math>U_s</math></b>	V	24	110 ... 230
<b>Rated frequency of the control supply voltage</b>	Hz	--	50/60 ± 10 %
<b>Control supply voltage, max.</b>	V	30	253
<b>Typical actuating current</b>	mA	20	15
<b>Response voltage</b>	V	15	90
<b>Drop-out voltage</b>	V	5	< 40
<b>Operating times</b>			
• ON-delay	ms	1	5
• OFF-delay	ms	1 + max. one half-wave	30 + max. one half-wave

#### Circuit diagrams

DC control supply voltage

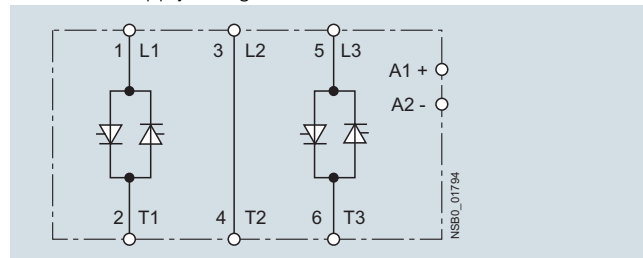

AC control supply voltage

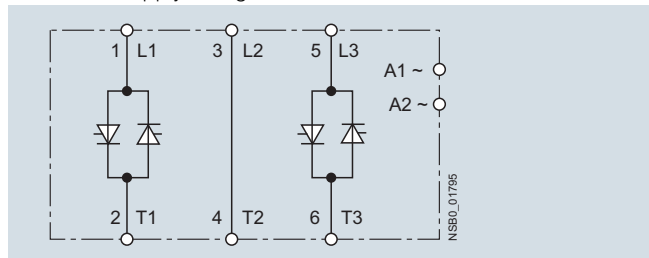





# Solid-State Switching Devices for Switching Motors

## Solid-State Contactors

### SIRIUS 3RF34 solid-state contactors, three-phase

#### Selection and ordering data

##### Motor contactors · Instantaneous switching · Two-phase controlled

Rated operational current $I_e$	Rated power at $I_e$ and $U_e$	Rated control supply voltage $U_s$	DT	Screw terminals		PU (UNIT, SET, M)	PS*	PG
				Configurator	Price per PU			
A	400 V kW	V		Article No.				
<b>Rated operational voltage <math>U_e</math></b>								
<b>48 ... 480 V AC</b>								
	5.2	2.2	24 DC	A	3RF3405-1BB04	1	1 unit	41C
	9.2	4.0		B	3RF3410-1BB04	1	1 unit	41C
	12.5	5.5		B	3RF3412-1BB04	1	1 unit	41C
	16	7.5		B	3RF3416-1BB04	1	1 unit	41C
	5.2	2.2	110 ... 230 AC	B	3RF3405-1BB24	1	1 unit	41C
	9.2	4.0		B	3RF3410-1BB24	1	1 unit	41C
	12.5	5.5		B	3RF3412-1BB24	1	1 unit	41C
	16	7.5		B	3RF3416-1BB24	1	1 unit	41C
<b>Rated operational voltage <math>U_e</math></b>								
<b>48 ... 600 V AC, blocking voltage 1 600 V</b>								
	5.2	2.2	24 DC	B	3RF3405-1BB06	1	1 unit	41C
	9.2	4.0		B	3RF3410-1BB06	1	1 unit	41C
	12.5	5.5		B	3RF3412-1BB06	1	1 unit	41C
	16	7.5		B	3RF3416-1BB06	1	1 unit	41C
	5.2	2.2	110 ... 230 AC	B	3RF3405-1BB26	1	1 unit	41C
	9.2	4.0		B	3RF3410-1BB26	1	1 unit	41C
	12.5	5.5		B	3RF3412-1BB26	1	1 unit	41C
	16	7.5		B	3RF3416-1BB26	1	1 unit	41C
<b>Rated operational voltage <math>U_e</math></b>								
<b>48 ... 480 V AC</b>								
	5.2	2.2	242 DC	B	3RF3405-2BB04	1	1 unit	41C
	9.2	4.0		B	3RF3410-2BB04	1	1 unit	41C
	12.5	5.5		B	3RF3412-2BB04	1	1 unit	41C
	16	7.5		B	3RF3416-2BB04	1	1 unit	41C
	5.2	2.2	110 ... 230 AC	B	3RF3405-2BB24	1	1 unit	41C
	9.2	4.0		B	3RF3410-2BB24	1	1 unit	41C
	12.5	5.5		B	3RF3412-2BB24	1	1 unit	41C
	16	7.5		B	3RF3416-2BB24	1	1 unit	41C
<b>Rated operational voltage <math>U_e</math></b>								
<b>48 ... 600 V AC, blocking voltage 1 600 V</b>								
	5.2	2.2	24 DC	B	3RF3405-2BB06	1	1 unit	41C
	9.2	4.0		B	3RF3410-2BB06	1	1 unit	41C
	12.5	5.5		B	3RF3412-2BB06	1	1 unit	41C
	16	7.5		B	3RF3416-2BB06	1	1 unit	41C
	5.2	2.2	110 ... 230 AC	B	3RF3405-2BB26	1	1 unit	41C
	9.2	4.0		B	3RF3410-2BB26	1	1 unit	41C
	12.5	5.5		B	3RF3412-2BB26	1	1 unit	41C
	16	7.5		B	3RF3416-2BB26	1	1 unit	41C







Online configurator see [www.siemens.com/sirius/configurators](http://www.siemens.com/sirius/configurators)

# Solid-State Switching Devices for Switching Motors

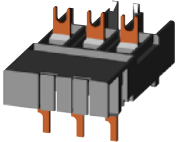
## Solid-State Contactors

### SIRIUS 3RF34 solid-state contactors, three-phase

#### Accessories

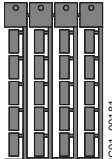
Version	DT	Article No.	Price per PU	PU (UNIT, SET, M)	PS*	PG
<b>Link modules between solid-state contactor and motor starter protector</b>						
 <p>3RA2921-1BA00</p>	A	<b>Link module</b> between solid-state contactor and motor starter protector with screw terminals For 3RV2 motor starter protectors size S00/S0	<b>Screw terminals</b> 	1	1 unit	41B
		3RA2921-1BA00				
<b>Link adapters between solid-state contactor and overload relay</b>						
 <p>3RF3900-0QA88</p>	A	<b>Link adapters</b> for direct mounting of 3RB3 overload relays or 3RR2 current monitoring relays to the solid-state contactor with screw terminals The adapter is snapped onto the enclosure of the 3RF34 contactor and accommodates the fixing hooks of the 3RB3 overload relays or the 3RR2 current monitoring relays for direct mounting.	<b>3RF3900-0QA88</b>	1	1 unit	41C
		3RF3900-0QA88				
<b>Insulation stop for securely holding back the conductor insulation on conductors up to 1 mm<sup>2</sup></b>						
 <p>3RT2916-4JA02</p>	B	<b>Insulation stop strip</b> for all SIRIUS devices with spring-type terminals Can be inserted in cable entry of the spring-type terminal (no more than 2 strips per contactor required; removable in pairs) for terminals with a conductor cross-section up to 2.5 mm <sup>2</sup>	<b>Spring-type terminals</b> 	1	20 units	41B
		3RT2916-4JA02				
<b>Tools for opening spring-type terminals</b>						
 <p>3RA2908-1A</p>	A	<b>Screwdrivers</b> for all SIRIUS devices with spring-type terminals Length approx. 200 mm, size 3.0 mm x 0.5 mm, titanium gray/black, partially insulated	<b>3RA2908-1A</b>	1	1 unit	41B
		3RA2908-1A				
<b>Blank labels</b>						
 <p>3SB2900-1SB20</p>	D	<b>Unit labeling plates</b> for SIRIUS devices <sup>1)</sup> <ul style="list-style-type: none"> <li>• 10 mm x 7 mm, titanium gray</li> <li>• 20 mm x 7 mm, titanium gray</li> </ul>	<b>3RT2900-1SB10</b>	100	816 units	41B
		D				
	D	<b>3RT2900-1SB60</b>	100	3060 units	41B	

<sup>1)</sup> PC labeling system for the individual inscription of unit labeling plates available from: murrplastik Systemtechnik GmbH (see Chapter 16, "Appendix" → "External Partners").

# Solid-State Switching Devices for Switching Motors

## Solid-State Contactors

### SIRIUS 3RF34 solid-state reversing contactors, three-phase

#### Overview

The integration of four conducting paths to a reverse switch, combined in one enclosure makes this device a particularly compact solution. Compared to conventional systems, for which two contactors are required, it is possible to save up to 50%

width with the three-phase reversing contactors. Devices with 45 mm width cover motors up to 2.2 kW – and those with 90 mm width up to 3 kW.

#### Technical specifications

Type		3RF3403-BD.4	3RF3405-BD.4	3RF3410-BD.4
<b>Fuseless design with 3RV2 motor starter protector, CLASS 10</b>				
<b>Rated operational current <math>I_{AC-53}</math><sup>1)</sup></b> according to IEC 60947-4-2				
• At 40 °C	A	3.8 (3.4)	5.4 (4.8)	7.4
• UL/CSA, at 50 °C	A	3.5 (3.1)	5 (4.3)	6.8
• At 60 °C	A	3.2 (2.8)	4.6 (3.8)	6.2
<b>Power loss at <math>I_{AC-53}</math></b>				
• At 40 °C	W	7 (6)	9 (8)	13
<b>Short-circuit protection with type of coordination "1"</b> at an operational voltage of $U_b$ to 440 V				
• Motor starter protector, type		3RV2011-1FA10	3RV2011-1GA10	3RV2011-1JA10
• Current $I_q$	kA	50	50	10

<sup>1)</sup> The reduced values in brackets apply to a directly mounted circuit breaker and simultaneous side-by-side mounting.

Type		3RF3403-BD.4	3RF3405-BD.4	3RF3410-BD.4
<b>Fused design with directly connected 3RB3 overload relay</b>				
<b>Rated operational current <math>I_{AC-53}</math></b> according to IEC 60947-4-2				
• At 40 °C	A	3.8	5.4	7.4
• UL/CSA, at 50 °C	A	3.5	5	6.8
• At 60 °C	A	3.2	4.6	6.2
<b>Power loss at <math>I_{AC-53}</math></b>				
• At 40 °C	W	6	8	16
<b>Minimum load current</b>	A	0.5		
<b>Max. off-state current</b>	mA	10		
<b>Rated peak withstand current <math>I_{tSM}</math></b>	A	200	600	
<b><math>I^2t</math> value</b>	A <sup>2</sup> s	200	1 800	

Type		3RF34...BD.4
<b>Main circuit</b>		
<b>Controlled phases</b>		2-phase
<b>Rated operational voltage <math>U_e</math><sup>1)</sup></b>	V AC	48 ... 480
• Operating range	V AC	40 ... 506
• Rated frequency	Hz	50/60 ± 10 %
<b>Rated insulation voltage <math>U_i</math></b>	V	600
<b>Rated impulse withstand voltage <math>U_{imp}</math></b>	kV	6
<b>Blocking voltage</b>	V	1 200
<b>Rate of voltage rise</b>	V/μs	1 000

<sup>1)</sup> To reduce the risk of a phase short circuit due to overvoltage, we recommend implementing a varistor type 3TX7462-3L between the phases L1 and L3 as close as possible to the switchgear.

We recommend a design with semiconductor protection as short-circuit protection.

# Solid-State Switching Devices for Switching Motors

## Solid-State Contactors

### SIRIUS 3RF34 solid-state reversing contactors, three-phase

Type	<b>3RF34...BD0.</b>		<b>3RF34...BD2.</b>
<b>Control circuit</b>			
<b>Method of operation</b>	DC operation		AC operation
<b>Rated control supply voltage <math>U_s</math></b>	V	24	110 ... 230
<b>Rated frequency of the control supply voltage</b>	Hz	--	50/60 ± 10 %
<b>Control supply voltage, maximum</b>	V	30	253
<b>Typical actuating current</b>	mA	15	10
<b>Response voltage</b>	V	15	90
<b>Drop-out voltage</b>	V	5	< 40
<b>Operating times<sup>1)</sup></b>			
• ON-delay	ms	5	20
• OFF-delay	ms	5 + max. one half-wave	10 + max. one half-wave
• Interlocking time	ms	60 ... 100	50 ... 100

<sup>1)</sup> Caution! Risk of phase short circuit in automatic mode.  
The control inputs must not be actuated until after a delay time of 40 ms after the main voltage is applied.

### Circuit diagrams

DC control supply voltage

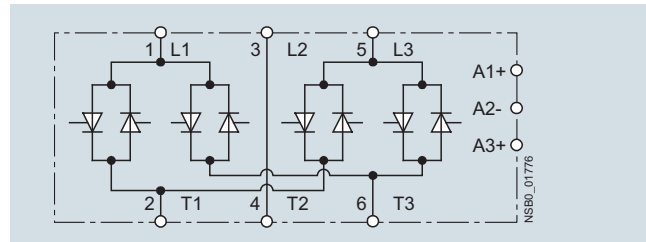

AC control supply voltage

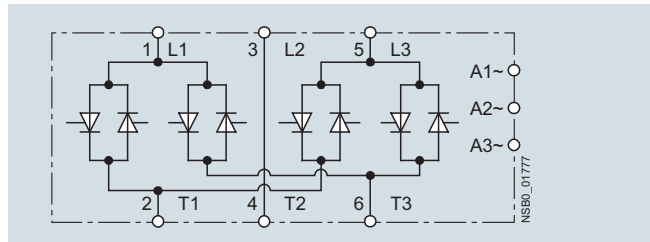



# Solid-State Switching Devices for Switching Motors

## Solid-State Contactors

### SIRIUS 3RF34 solid-state reversing contactors, three-phase



#### Selection and ordering data

##### Reversing contactors · Instantaneous switching · Two-phase controlled

Rated operational current $I_e$	Rated power at $I_e$ and $U_e$ kW	Rated control supply voltage $U_s$ V	DT	Screw terminals	PU (UNIT, SET, M)	PS*	PG
				Configurator			
Rated operational voltage $U_e$ 48 ... 480 V AC				Article No.	Price per PU		
 3RF3403-1BD	3.8	1.5	24 DC	A	<b>3RF3403-1BD04</b>	1	1 unit 41C
	5.4	2.2		B	<b>3RF3405-1BD04</b>	1	1 unit 41C
	7.4	3.0		B	<b>3RF3410-1BD04</b>	1	1 unit 41C
 3RF3410-1BD	3.8	1.5	110 ... 230 AC	B	<b>3RF3403-1BD24</b>	1	1 unit 41C
	5.4	2.2		B	<b>3RF3405-1BD24</b>	1	1 unit 41C
	7.4	3.0		B	<b>3RF3410-1BD24</b>	1	1 unit 41C

Online configurator see [www.siemens.com/sirius/configurators](http://www.siemens.com/sirius/configurators)

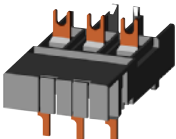
#### Accessories

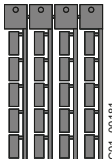
Version	DT	Article No.	Price per PU	PU (UNIT, SET, M)	PS*	PG
<b>Link modules between solid-state contactor and motor starter protector</b>						
 3RA2921-1BA00		<b>Screw terminals</b>				
		<b>Link module</b> between solid-state reversing contactor and motor starter protector with screw terminals For 3RV2 motor starter protectors, size S00/S0	A	<b>3RA2921-1BA00</b>	1	1 unit 41B
<b>Link adapters between solid-state contactor and overload relay</b>						
 3RF3900-0QA88		<b>Link adapters</b>				
		for direct mounting of 3RB3 overload relays or 3RR2 current monitoring relays to the solid-state contactor with screw terminals The adapter is snapped onto the enclosure of the 3RF34 contactor and accommodates the fixing hooks of the 3RB3 overload relays or the 3RR2 current monitoring relays for direct mounting.	A	<b>3RF3900-0QA88</b>	1	1 unit 41C
<b>Blank labels</b>						
 3SB2900-1SB20		<b>Unit labeling plates</b>				
		for SIRIUS devices <sup>1)</sup> <ul style="list-style-type: none"> <li>• 10 mm × 7 mm, titanium gray</li> <li>• 20 mm × 7 mm, titanium gray</li> </ul>	D	<b>3RT2900-1SB10</b>	100	816 units 41B
			D	<b>3RT2900-1SB20</b>	100	340 units 41B
		<b>Adhesive labels</b>				
		for SIRIUS devices <ul style="list-style-type: none"> <li>• 19 mm × 6 mm, titanium gray</li> </ul>	D	<b>3RT2900-1SB60</b>	100	3060 units 41B

<sup>1)</sup> PC labeling system for the individual inscription of unit labeling plates available from: murrplastik Systemtechnik GmbH (see Chapter 16, "Appendix" → "External Partners").

# Solid-State Switching Devices for Switching Motors

## Solid-State Contactors

Notes

6